

### 6-100103-0 Product Details

Share | Print | Email

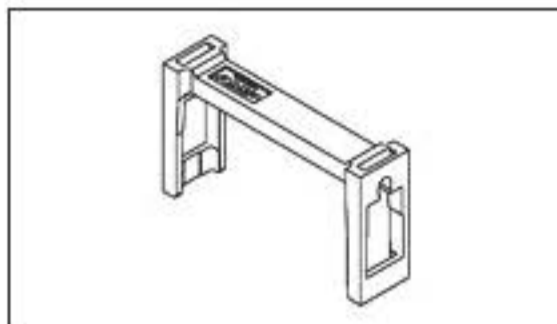

6-100103-0

TE Internal Number: 6-100103-0

Active

View 3D PDF

#### AMP-LATCH Accessories

Always EU RoHS/ELV Compliant (Statement of Compliance)

#### Product Highlights:

- Accessory Type = Strain Relief
- 60 Positions
- RoHS compliant, ELV compliant
- Lead Free Solder Processes = Not relevant for lead free process

View all Features

#### Quick Links

- ▶ Pricing & Availability
- ▶ Search for Tooling
- ▶ Product Feature Selector
- ▶ Contact Us About This Product

Add to My Part List | Request Sample | Find Similar Products | Buy Product

#### Documentation & Additional Information

##### Product Drawings:

- AMP-LATCH MIL-TYPE RECEIPT (PDF, English)

##### Catalog Pages/Data Sheets:

- None Available

##### Product Specifications:

- None Available

##### Application Specifications:

- None Available

##### Instruction Sheets:

- None Available

##### CAD Files: (CAD Format & Compression Information)

- 2D Drawing (DXF, Version B)
- 3D Model (IGES, Version B)
- 3D Model (STEP, Version B)

##### Additional Information:

- Product Line Information

##### Related Products:

- Tooling

List all Documents

#### Product Features (Please use the Product Drawing for all design activity)

##### Product Type Features:

- Accessory Type = Strain Relief
- Color = Gray

##### Body Features:

- Body Material = Glass-Filled Nylon

##### Configuration Features:

- Number of Positions = 60

##### Industry Standards:

- RoHS/ELV Compliance = RoHS compliant, ELV compliant
- Lead Free Solder Processes = Not relevant for lead free process
- RoHS/ELV Compliance History = Always was RoHS compliant

##### Packaging Features:

- Packaging Method = Bag
- Packaging Quantity = 250

##### Other:

- Brand = AMP

#### Corporate Information

- About TE
- Investors
- News Room
- Supplier Portal
- Careers
- Terms & Conditions
- Privacy Policy

#### Quick Links

- Distributor Inventory
- Product Cross Reference
- Documents & Drawings
- Product Compliance Support Center
- Site Map

#### Customer Support

- Email or Chat With Us
- Find a Phone Number
- Knowledge Base
- Manage Your Account

#### Keep Me Informed

Receive TE News, Events & Technology Updates

Enter your email address

