

THIS DRAWING IS UNPUBLISHED. RELEASED FOR PUBLICATION  
 © COPYRIGHT BY TYCO ELECTRONICS CORPORATION. ALL INTERNATIONAL RIGHTS RESERVED.

LOC		DIST		REVISIONS			
P	LTR	DESCRIPTION	DATE	DWN	APVD		
	A	PRODUCTION RELEASE	03 SEP 08	BJR	MKS		

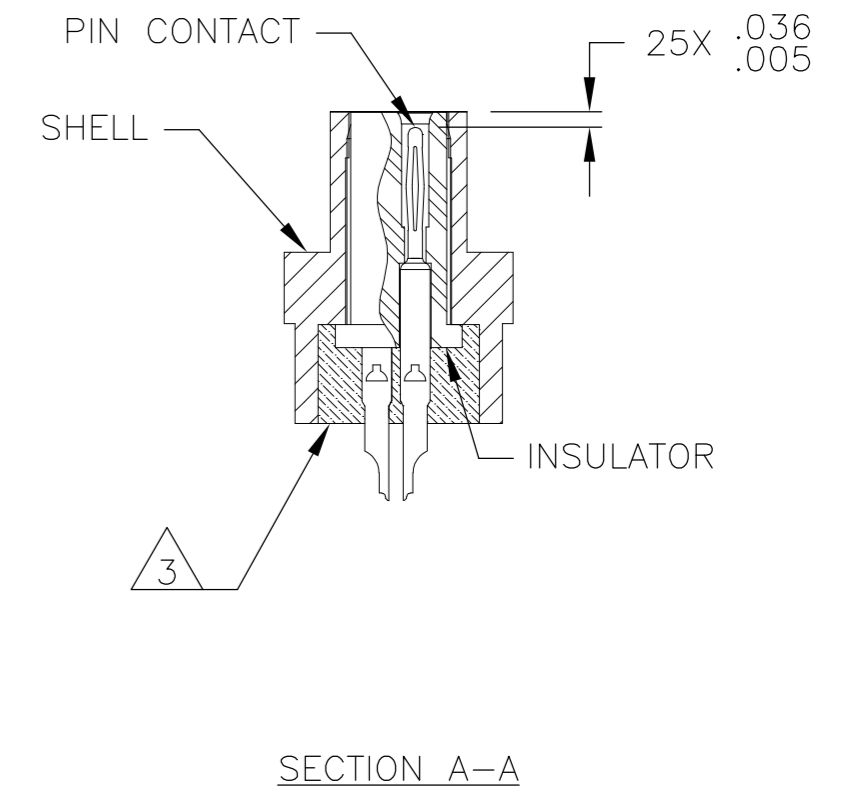
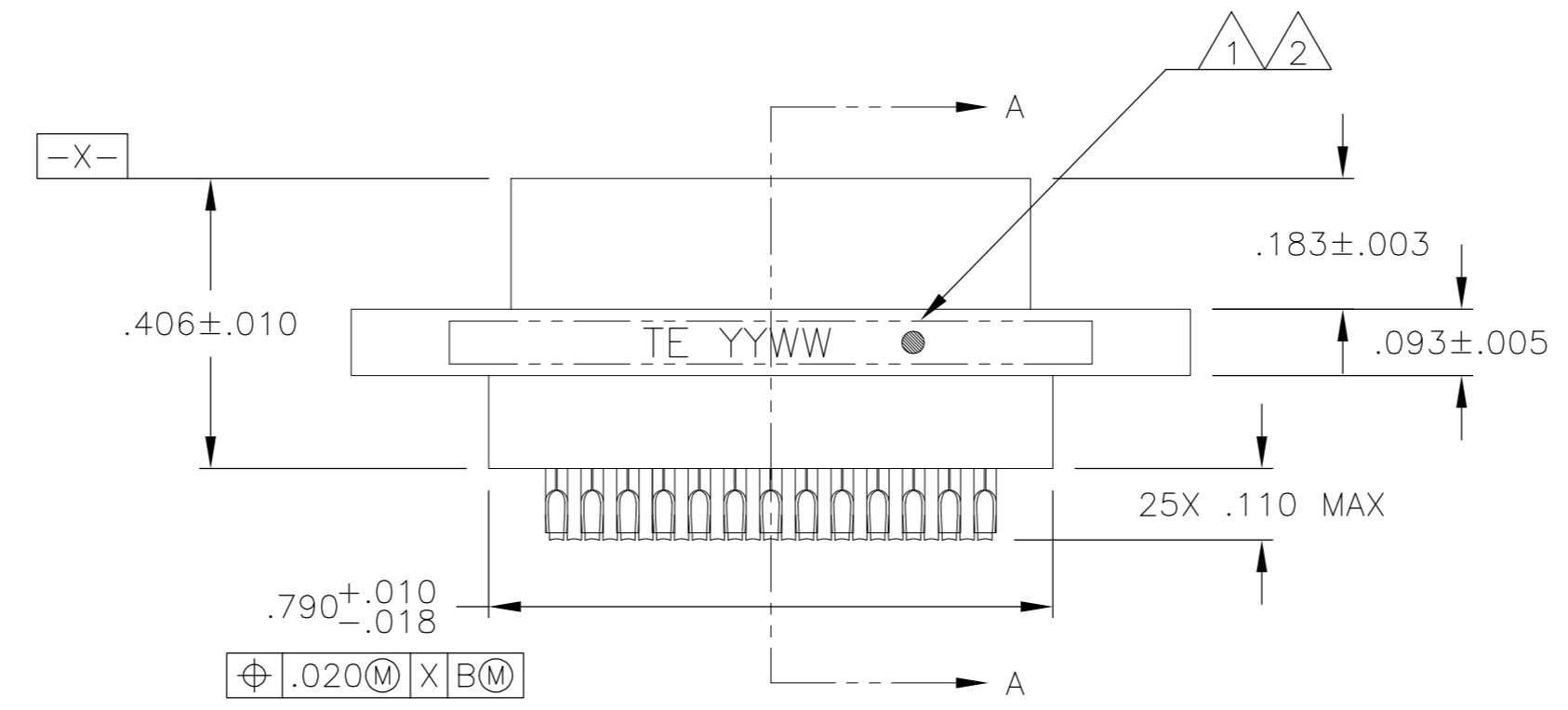
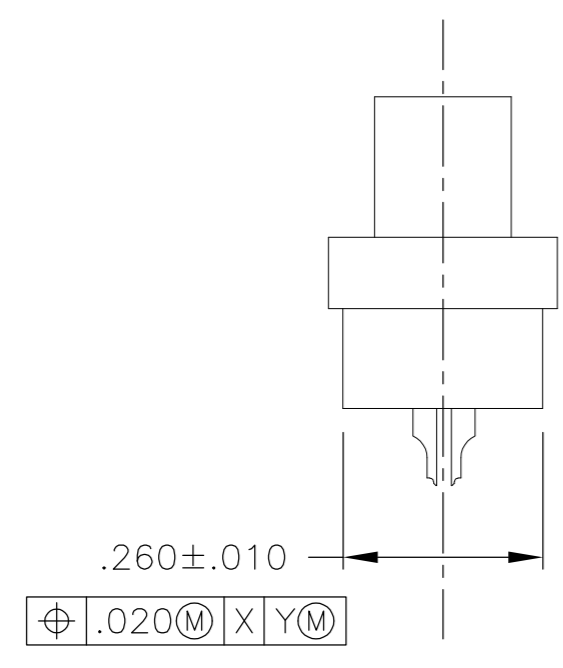
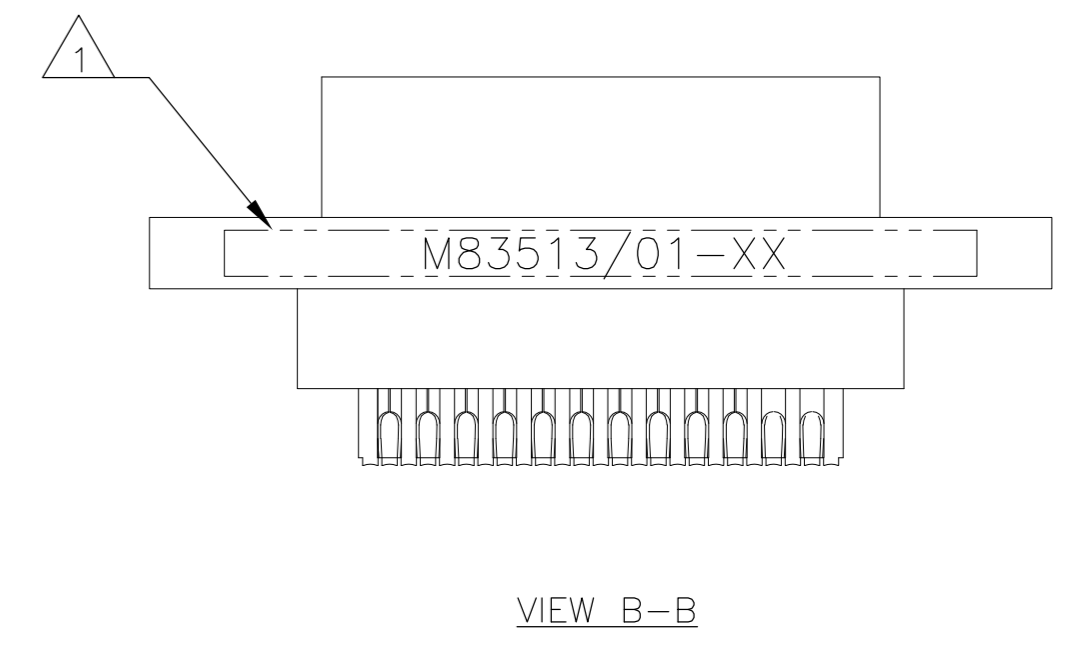
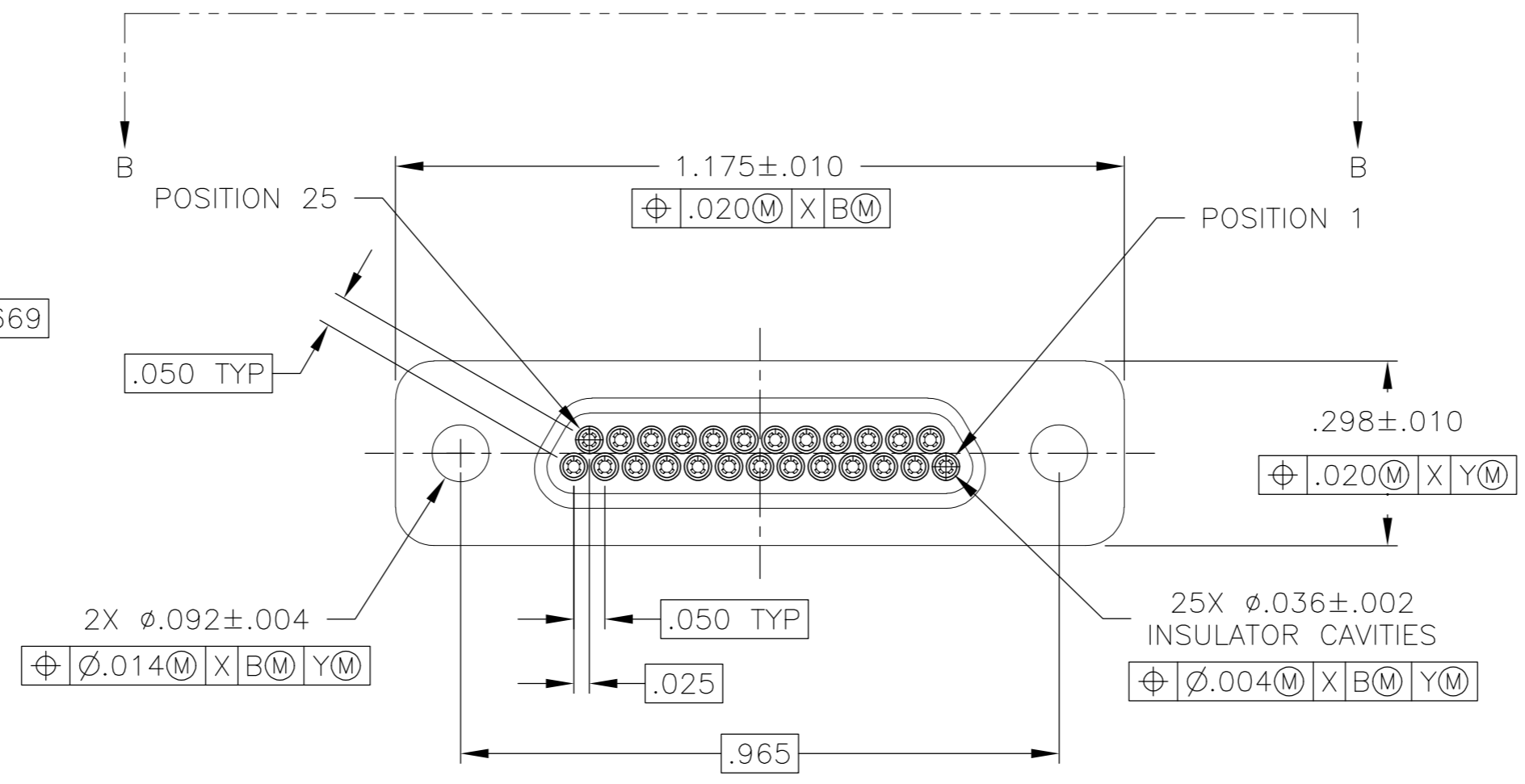
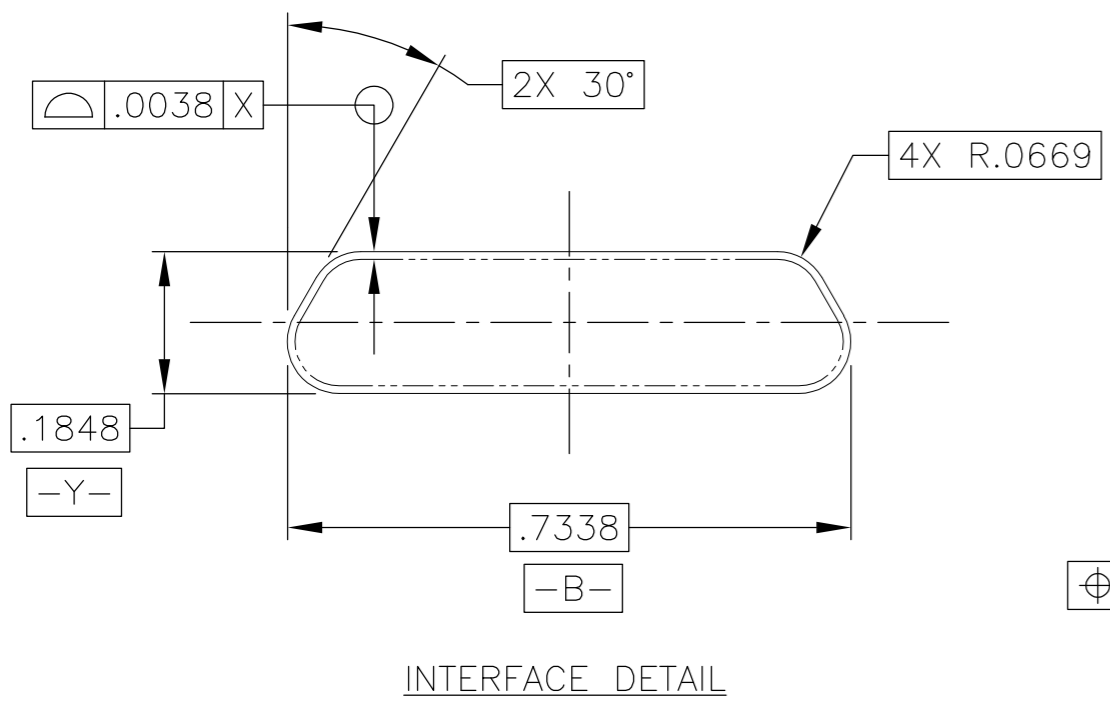

- 1 CONNECTOR SHALL BE MARKED IN ACCORDANCE WITH METHOD I OF MIL-STD-1285. MARKING SHALL CONTAIN THE MILITARY PIN, CAGE CODE (OR TE), AND DATE CODE. EXAMPLE: M83513/01-XX TE YYWW (WHERE XX IS PART OF THE PIN SHOWN IN THE "MIL-DTL-83513" COLUMN OF THE PART NUMBER TABLE, AND YYWW IS THE DATE CODE). FOR THE SIZE 25 PLUG, THE MARKING MUST BE PRINTED ON BOTH SIDES OF THE FLANGE. TEXT HEIGHT SHALL BE .035 INCH MINIMUM.
- 2 POSITION 1 SHALL BE INDICATED BY AN IDENTIFIABLE MARK, LOCATED APPROXIMATELY AS SHOWN ON THE POSITION 1 SIDE OF THE CONNECTOR FLANGE. THIS MARK SHALL BE INCLUDED AS PART OF THE PART MARKING INFORMATION.
- 3 EPOXY ENCAPSULATION. EPOXY MAY WICK .050 INCH MAX FOR SOLDER CUPS.
- 4 ALL DIMENSIONS AND REQUIREMENTS ARE PER MIL-DTL-83513/1

THIS DRAWING IS A CONTROLLED DOCUMENT.		DWN B. ROMANCHUK	03 SEP 08	Tyco Electronics Corporation Harrisburg, PA 17105-3608	
DIMENSIONS: INCHES		CHK -	APVD M. STORRY	03 SEP 08	NAME PLUG ASSEMBLY, MICRO-D PER MIL-DTL-83513/01, MCKS SERIES, 25 POSITION
TOLERANCES UNLESS OTHERWISE SPECIFIED: 0 PLC ± - 1 PLC ± - 2 PLC ± .010 3 PLC ± .005 4 PLC ± - ANGLES ± 1° FINISH -		PRODUCT SPEC APPLICATION SPEC		SIZE A2	CAGE CODE 98278
MATERIAL SEE NOTES		WEIGHT -		DRAWING NO 1532212	RESTRICTED TO -
CUSTOMER DRAWING			SCALE 4:1	SHEET 1 of 2	REV A

