

**SMA Connectors (Continued)**  
**Flexible Cable**

**Bulkhead Feedthrough Cable Jack, Clamp**

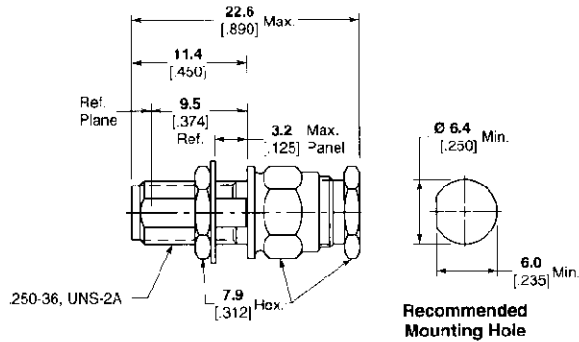
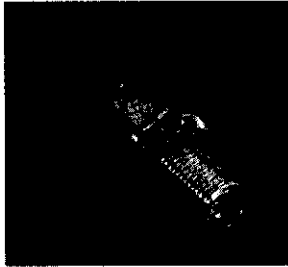

Cable Type RG/J	Body Material & Finish	Contact Captivation	Contact Attachment	Instruction Sheet	M/A-COM Model No.	Part No.
174, 188, 316	Stainless, Pass.	Yes	Solder	408-4704	2004-7188-02	1050996-1

**Right Angle Cable Plug, Clamp**

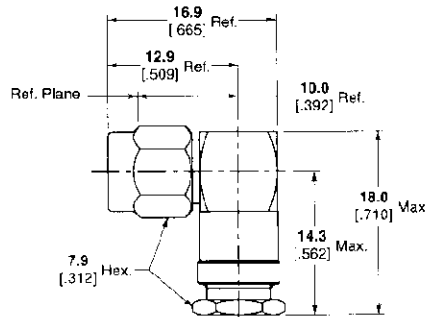
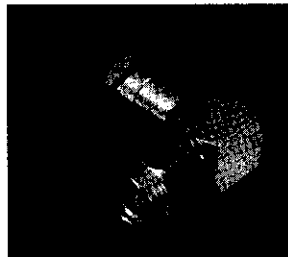

Cable Type RG/U	Body Material & Finish	Contact Captivation	Contact Attachment	Instruction Sheet	M/A-COM Model No.	Part No.
RG 55, 58, 141, 300	Stainless, Gold	Mechanical	Solder	408-4965	2007-7141-00	1051136-1
174, 188, 316	Stainless, Pass.	Mechanical	Solder	408-4965	2007-7188-02	1051140-1

**Straight Cable Plug, Crimp**

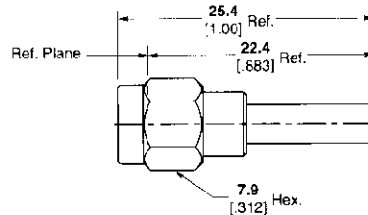
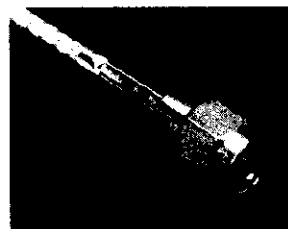

Cable Type RG/U	Body Material & Finish	Contact Captivation	Contact Attachment	Crimp Tooling Part No.	Instruction Sheet	M/A-COM Model No.	Part No.
174, 179, 187, 188, 316	Stainless, Pass.	Mechanical	Solder/Crimp <sup>2</sup>	1055236-1	408-4661	2831-7388-02	1056443-1
RD316	Stainless, Pass.	Mechanical	Solder/Crimp <sup>2</sup>	1055236-1 <sup>1</sup>	408-4661	2831-7316-02	1056436-1
58, 141, 303	Stainless, Pass.	Mechanical	Solder/Crimp <sup>2</sup>	1055236-1	408-4661	2831-7358-02	1056441-1
55, 142, 223, 400	Stainless, Pass.	Mechanical	Solder/Crimp <sup>2</sup>	1055236-1	408-4661	2831-7341-02	1056438-1
174, 179, 187, 188, 316	Brass, White Bronze	Mechanical	Solder/Crimp <sup>2</sup>	1055236-1	408-4661	2231-7388-36	1082034-1

<sup>1</sup>Use die 1055270-1 to crimp RD316 ferrule.  
<sup>2</sup>Use die 1055880-1 to crimp center contact.