

WITH ATTACHMENT

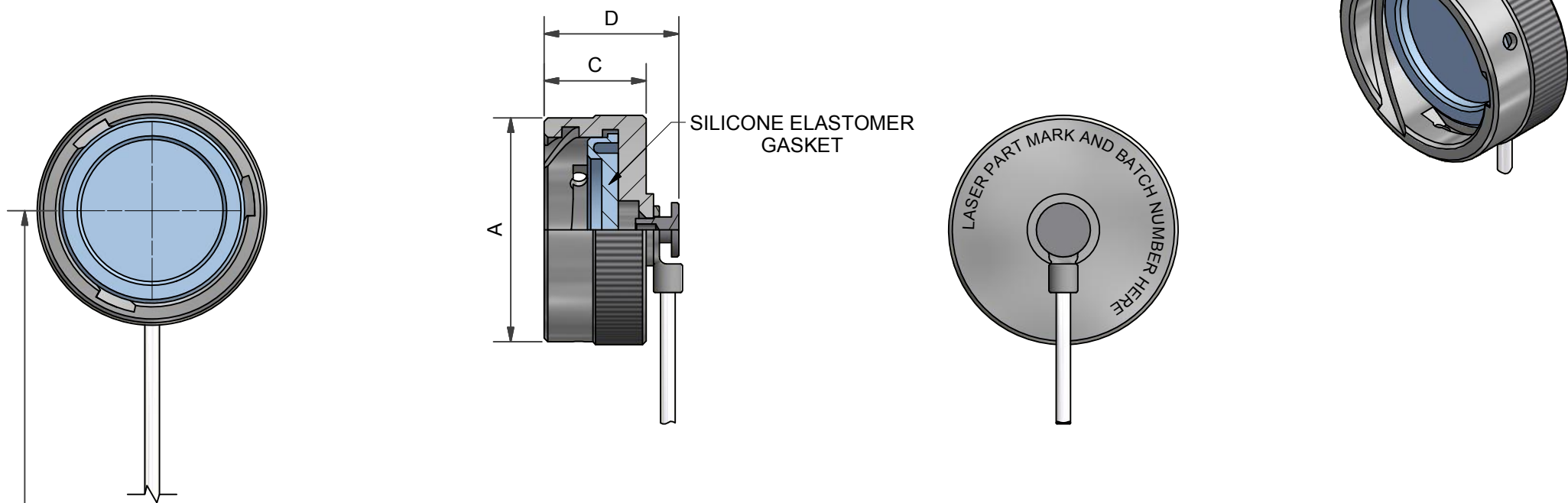

ATTACHMENT OPTIONS:

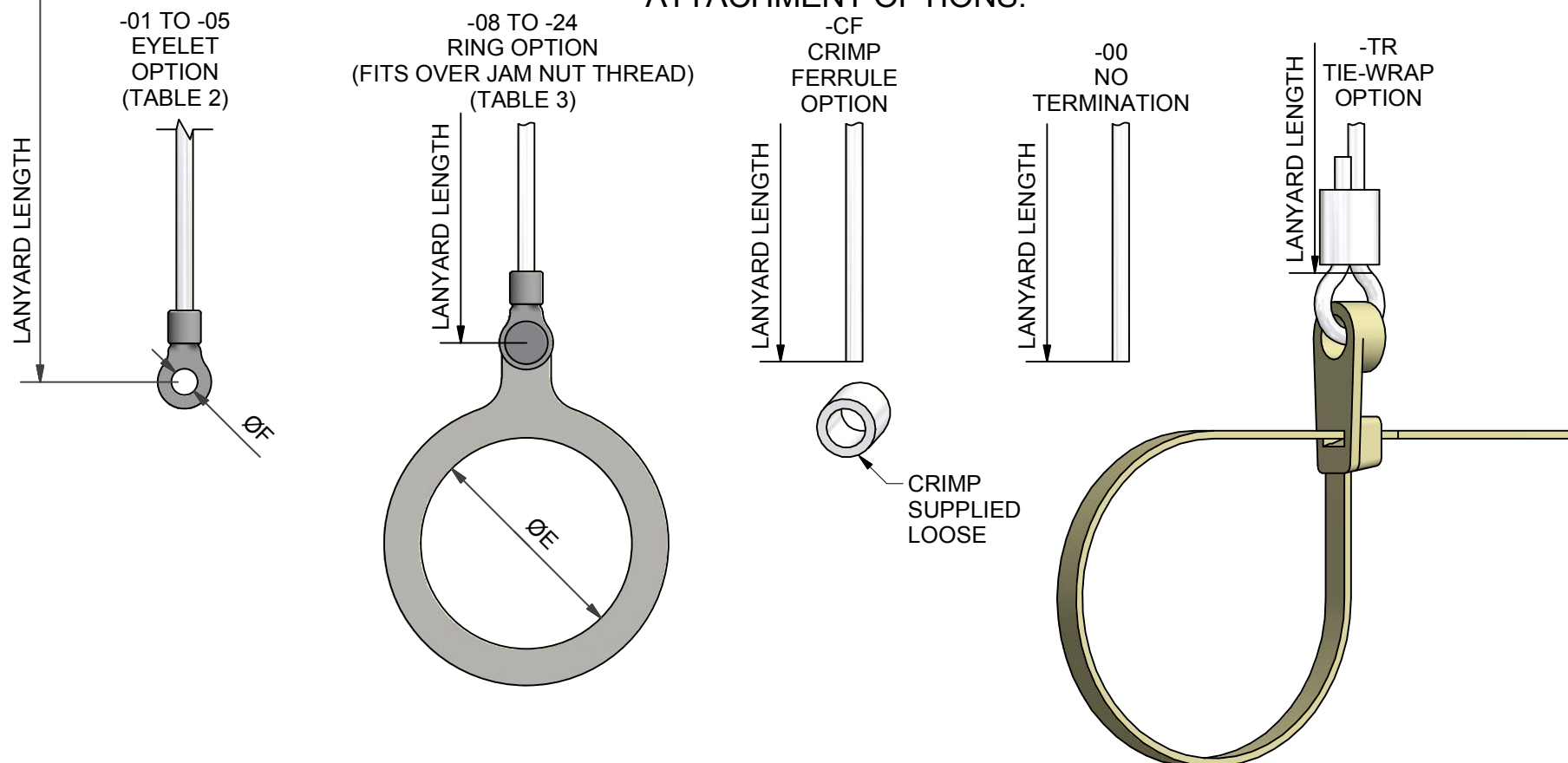

OMIT FOR NO ATTACHMENT
(SEE SHEET 2)

PRC3181-16-1-D-NK5-03

SERIES _____
 INSERT R FOR ARCTIC _____
 GRIP VERSION _____
 SHELL SIZE (TABLE 1) _____
 MATERIAL (TABLE 5) _____
 FINISH (TABLE 6) _____
 LANYARD TYPE (TABLE 4) _____
 LANYARD LENGTH (IN INCHES) _____
 +1.0"/-0" TOLERANCE _____
 ATTACHMENT (SEE ABOVE) _____

DRAWN K.WINCZURA		DATE 04/01/2013		 3RD ANGLE PROJECTION NOT TO SCALE	PART NUMBER: PRC3181 SERIES			 Polamco
APPROVED BY M.PAUL		DATE 16/11/2018			TITLE: RECEPTACLE PROTECTION COVER			
CHECKED BY K.SHEPPARD		DATE 07/01/2013		UNLESS OTHERWISE SPECIFIED ALL DIMENSIONS IN MILLIMETRES GENERAL TOL LINEAR +/-0,25MM ANGULAR +/- 1°			ASSY USED ON: MIL-DTL-26482 SERIES I & II	
DOC TYPE Customer Drawing		MATERIAL SEE TABLE 5		FINISH SEE TABLE 6			RESTRICTED TO:	
ISSUE/REV AA		DCR ---		THIS DRAWING IS COPYRIGHT AND THE PROPERTY OF POLAMCO LTD IT MUST NOT BE COPIED, USED FOR MANUFACTURE OR OTHERWISE DISCLOSED WITHOUT PRIOR WRITTEN CONSENT OF THE COMPANY.			POLAMCO LTD, WESTON LOCK, LOWER BRISTOL ROAD BATH BA2 1EP	
NCAGE CODE U5792		WEIGHT N/A		SHT 1			DRAWING NO: P25639	



ARCTIC GRIP VERSION

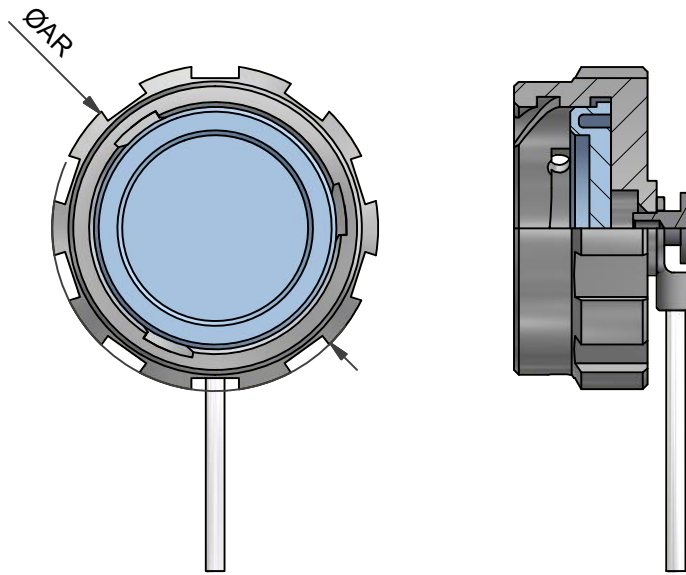

TABLE 1

SHELL SIZE	ØA MAX	ØAR MAX	C MAX	D MAX
08	18,64	21,34	14,27	21,44
10	21,82	24,52	14,27	21,44
12	25,40	28,10	14,27	21,44
14	28,58	31,28	14,27	21,44
16	31,75	34,45	14,27	21,44
18	34,92	37,62	14,27	21,44
20	38,10	40,80	14,27	21,44
22	41,28	43,98	14,27	21,44
24	44,45	47,15	15,29	22,22

TABLE 2

EYELET REF.	ØF
01	3,2
02	3,7
03	4,3
04	5,3
05	6,4

TABLE 3

RING REF.	ØE
08	15,1
10	18,0
12	22,6
14	25,8
16	28,8
18	32,0
20	35,0
22	38,3
24	41,7

TABLE 4

CODE	LANYARD TYPE
WR	NYLON COVERED (CLEAR) STAINLESS STEEL WIRE ROPE
TC	TEFLON COVERED (CLEAR) STAINLESS STEEL WIRE ROPE
WG	TEFLON COVERED (OLIVE DRAB) STAINLESS STEEL WIRE ROPE
WB	TEFLON COVERED (BLACK) STAINLESS STEEL WIRE ROPE
WRB	PVC COVERED (BLACK) STAINLESS STEEL WIRE ROPE
LC	LINK CHAIN
BK	BLACK CORD
VGB	1,5mm BLACK POLYESTER CORD EQV. TO DIN83330-E1,5
B	BEAD CHAIN
R	OLIVE DRAB POLYESTER CORD
NB	OLIVE DRAB NYLON CORD
NK	BLACK NYLON CORD

TABLE 5

CODE	MATERIAL
1	ALUMINIUM
2	NICKEL ALUMINIUM BRONZE
4	STAINLESS STEEL
7	BLACK ACETAL
74	COMPOSITE

SEE SS0076 FOR FULL RANGE OF MATERIAL OPTIONS

CODE	DESCRIPTION
B	CADMIUM, OLIVE DRAB OVER ELECTROLESS NICKEL
C	ELECTROLESS NICKEL
G	BLACK ANODISE, SULPHURIC
J	PASSIVATE
U	UNPLATED CLEAN FINISH NOT SHOT BLASTED
Z	SHOT BLAST FOR NON-REFLECTIVE FINISH
ZB	ZINC COBALT OLIVE DRAB OVER ELECTROLESS NICKEL
ZN	ZINC NICKEL BLACK PASSIVATE OVER ELECTROLESS NICKEL

SEE SS0076 FOR FULL RANGE OF FINISH OPTIONS

WITHOUT ATTACHMENT



PRC3181-16-1-C
NO ATTACHMENT VERSION

PRC3181-16-1-C-EO
EYELET ONLY VERSION
(NO LANYARD)

DRAWN K.WINCZURA		DATE 04/01/2013		<p>3RD ANGLE PROJECTION NOT TO SCALE</p>	PART NUMBER: PRC3181 SERIES		<p>Polamco</p>
APPROVED BY M.PAUL		DATE 16/11/2018			TITLE: RECEPTACLE PROTECTION COVER		
CHECKED BY K.SHEPPARD		DATE 07/01/2013		UNLESS OTHERWISE SPECIFIED ALL DIMENSIONS IN MILLIMETRES GENERAL TOL LINEAR +/-0,25MM ANGULAR +/- 1°		ASSY USED ON: MIL-DTL-26482 SERIES I & II	
DOC TYPE Customer Drawing		ISSUE/REV AA		MATERIAL SEE TABLE 5		RESTRICTED TO:	
WEIGHT N/A		DCR ---		FINISH SEE TABLE 6		POLAMCO LTD, WESTON LOCK, LOWER BRISTOL ROAD BATH BA2 1EP	
NCAGE CODE U5792				THIS DRAWING IS COPYRIGHT AND THE PROPERTY OF POLAMCO LTD IT MUST NOT BE COPIED, USED FOR MANUFACTURE OR OTHERWISE DISCLOSED WITHOUT PRIOR WRITTEN CONSENT OF THE COMPANY.		SHT 2	
						DRAWING NO: P25639	