

ANGLE 1

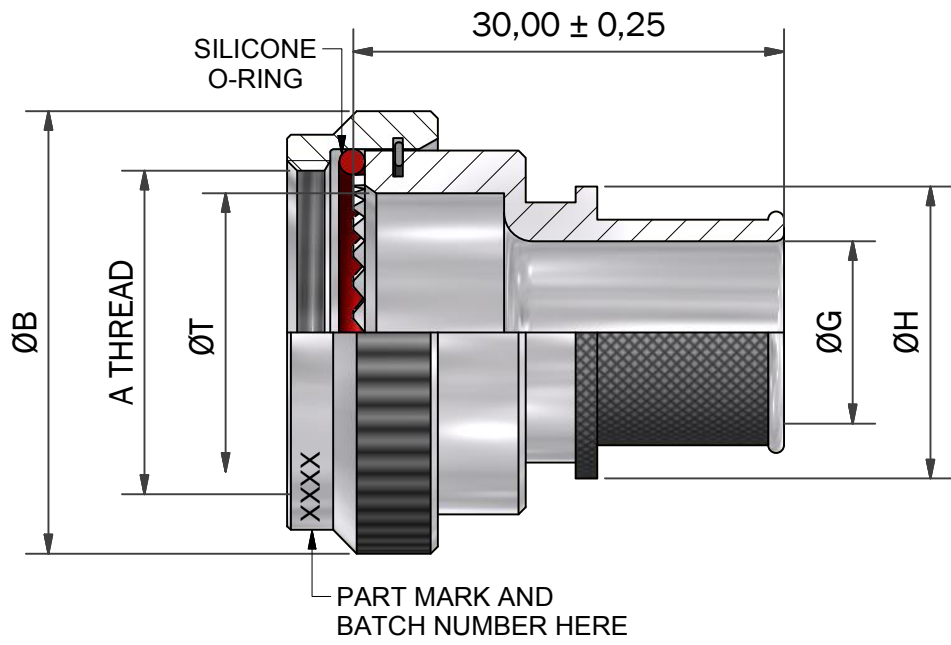

SLOT OPTION - SL
(PIGTAIL TERMINATION)

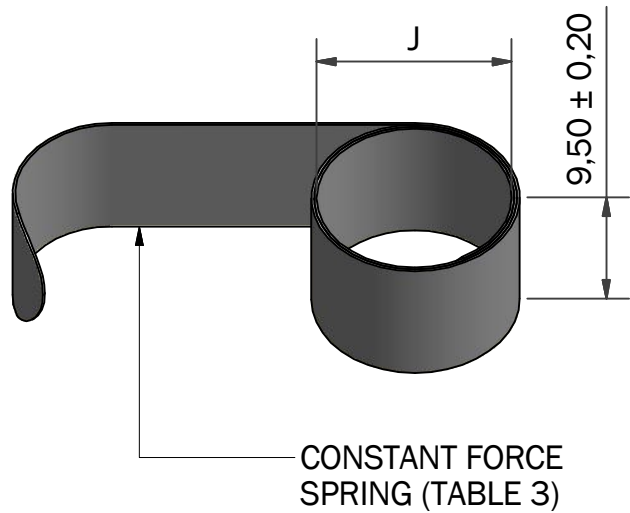
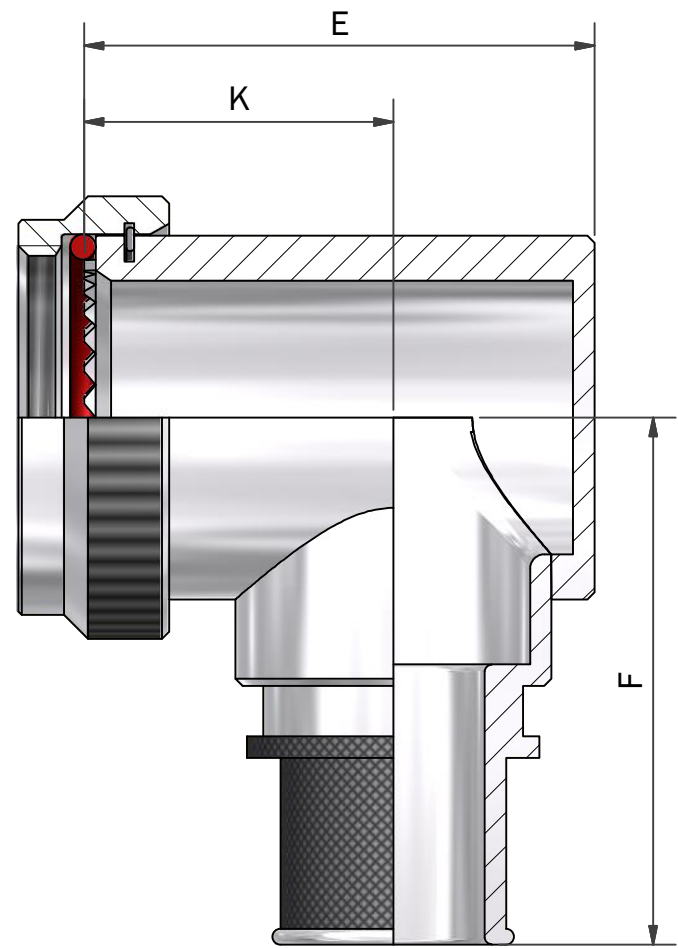
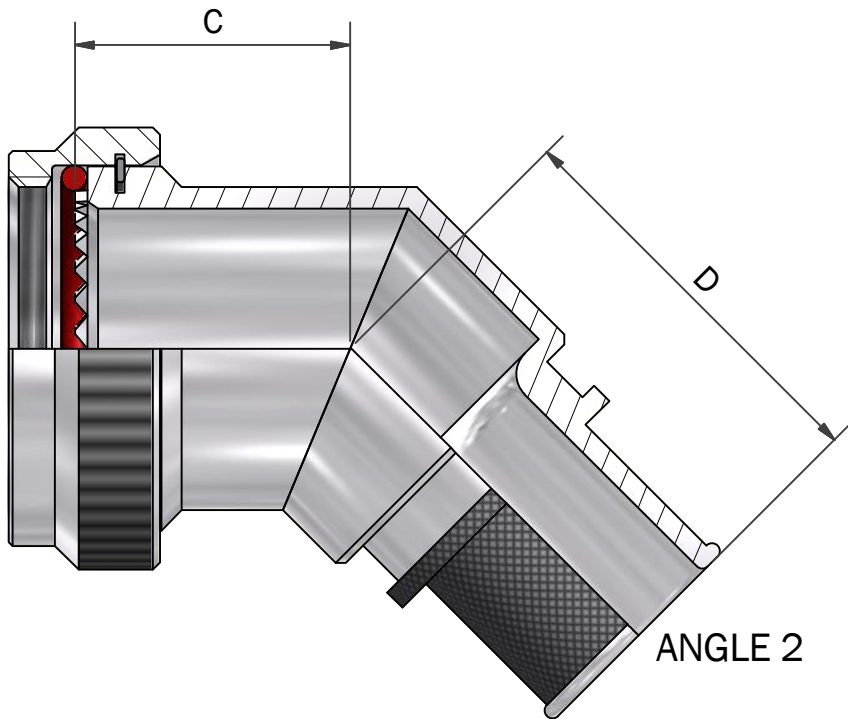
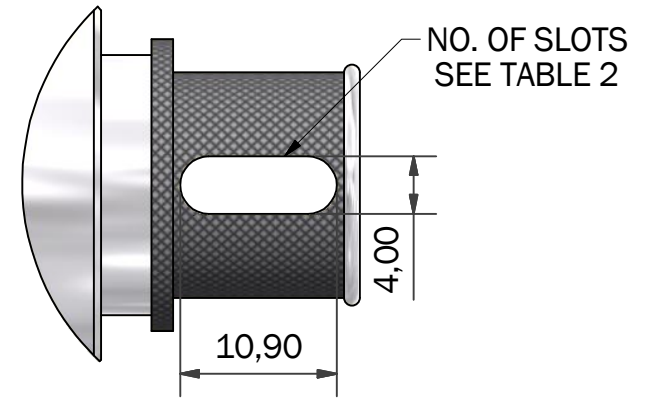

DRAWN	K.SHEPPARD	DATE	08/07/2014	3RD ANGLE PROJECTION NOT TO SCALE	POLAMCO LTD WESTON LOCK LOWER BRISTOL ROAD BATH BA2 1EP	PAGE 1	UNLESS OTHERWISE SPECIFIED ALL DIMENSIONS IN MILLIMETRES
SALES APPR							
DESIGN APPR				THIS DRAWING IS COPYRIGHT AND THE PROPERTY OF POLAMCO LTD. IT MUST NOT BE COPIED, USED FOR MANUFACTURE OR OTHERWISE DISCLOSED WITHOUT PRIOR WRITTEN CONSENT OF THE COMPANY.	ASSY USED ON: MIL-DTL-38999 SERIES II TITLE: SPRING ADAPTOR PART NUMBER: 91F SERIES	MATERIAL	
QUAL APPR						ALUMINIUM ALLOY 6262	
ISSUE	7	DCR	6180			NCAGE CODE U5792	
WEIGHT		GENERAL TOL	LINEAR +/-0.1MM ANGULAR +/- 1°			DRAWING NO: P11312	

TABLE 1

SHELL SIZE	A THREAD	ØB MAX	ØT MIN	C ±0,5	D MAX	E MAX	F MAX	K ±0,5
08	7/16-28 UNEF	18,3	6,6	16,4	25,7	22,7	30,5	15,0
10	9/16-24 UNEF	21,5	10,1	17,2	26,9	26,2	32,2	17,0
12	11/16-24 UNEF	24,5	12,9	17,6	27,3	29,2	33,7	18,0
14	13/16-20 UNEF	27,8	16,1	18,5	28,2	32,2	35,2	20,0
16	15/16-20 UNEF	30,8	19,3	19,2	29,0	35,7	36,9	21,5
18	1 1/16-18 UNEF	34,1	21,7	19,6	29,3	39,7	38,5	23,0
20	1 3/16-18 UNEF	37,3	24,9	20,4	30,1	42,2	41,1	25,0
22	1 5/16-18 UNEF	40,5	28,1	20,8	30,5	45,2	41,6	26,0
24	1 7/16-18 UNEF	43,7	31,3	21,7	31,4	48,2	43,1	28,0

TABLE 2

ENTRY SIZE	ØG MIN	ØH +/-0,25	SPRING REF	NO. OF SLOTS *
03	4,7	14,0	HE050	1
04	6,3	14,0	HE050	1
05	7,9	15,5	HE100	1
06	9,5	17,2	HE100	2
07	11,1	18,8	HE100	2
08	12,7	20,4	HE200	2
09	14,2	22,0	HE200	2
10	15,8	23,6	HE200	2
11	17,4	25,2	HE200	2
12	19,0	26,7	HE300	2
13	20,6	28,3	HE300	2
14	22,2	29,9	HE300	4
15	23,8	31,5	HE300	4
16	25,4	33,1	HE300	4
17	27,0	34,7	HE400	4
18	28,6	36,3	HE400	4
19	30,2	37,9	HE400	4
20	31,8	39,5	HE400	4
21	33,3	41,1	HE400	4
22	35,0	42,7	HE400	4
23	36,5	44,3	HE400	4
24	38,1	45,9	HE400	4

TABLE 3

SPRING REF	J MAX (UNCONSTRAINED)
HE 050	7,5
HE 100	9,1
HE 200	12,8
HE 300	17,9
HE 400	21,8

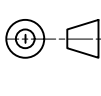

TABLE 4

CODE	FINISH
C	ELECTROLESS NICKEL
B	CADMIUM OLIVE DRAB OVER ELECTROLESS NICKEL
ZB	ZINC COBALT OLIVE DRAB OVER ELECTROLESS NICKEL
ZN	ZINC NICKEL BLACK PASSIVATE OVER ELECTROLESS NICKEL

LIST NOT EXHAUSTIVE, SEE PLATING TABLE FOR OTHER OPTIONS

91F1-16-08-1-C-HE200

SERIES _____
 CONNECTOR INTERFACE _____
 ANGLE _____
 SHELL SIZE (TABLE 1) _____
 ENTRY SIZE (TABLE 2) _____
 MATERIAL _____
 ALUMINIUM ALLOY
 FINISH (TABLE 4) _____
 *INSERT SL FOR SLOT OPTION _____
 OMIT FOR STANDARD
 SPRING REF (TABLE 2) _____
 OMIT IF NO SPRING REQUIRED

DRAWN K.SHEPPARD	DATE 08/07/2014	 3RD ANGLE PROJECTION NOT TO SCALE	 POLAMCO LTD WESTON LOCK LOWER BRISTOL ROAD BATH BA2 1EP	PAGE 2	UNLESS OTHERWISE SPECIFIED ALL DIMENSIONS IN MILLIMETRES
SALES APPR					
DESIGN APPR		THIS DRAWING IS COPYRIGHT AND THE PROPERTY OF POLAMCO LTD IT MUST NOT BE COPIED, USED FOR MANUFACTURE OR OTHERWISE DISCLOSED WITHOUT PRIOR WRITTEN CONSENT OF THE COMPANY.	ASSY USED ON: MIL-DTL-38999 SERIES II		MATERIAL ALUMINIUM ALLOY 6262
QUAL APPR			TITLE: SPRING ADAPTOR		
ISSUE 7	DCR 6180		PART NUMBER: 91F SERIES		NCAGE CODE U5792
WEIGHT	GENERAL TOL LINEAR +/-0.1MM ANGULAR +/- 1°			DRAWING NO: P11312	