

REVISIONS				
P	LTN	DESCRIPTION	DATE	APVD
A7		REVISED PER ECO-15-018007	11JAN2016	DLD DCM
A8		REVISED PER ECN-25-329232	07JUL2025	SR HC

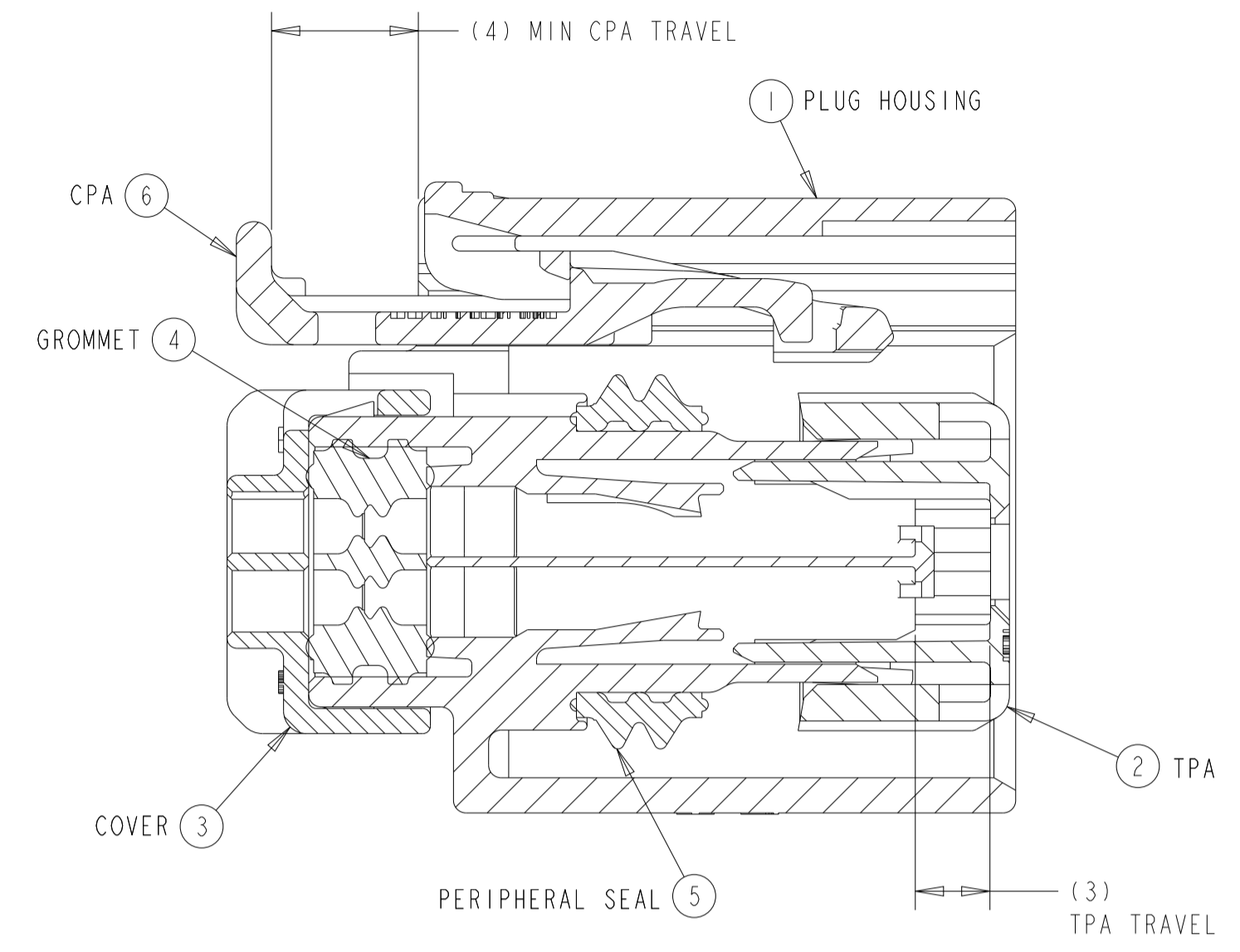

SECTION A-A
 SHOWN WITH TPA
 IN PRE-LOADED POSITION
 (DELIVERY CONDITION)

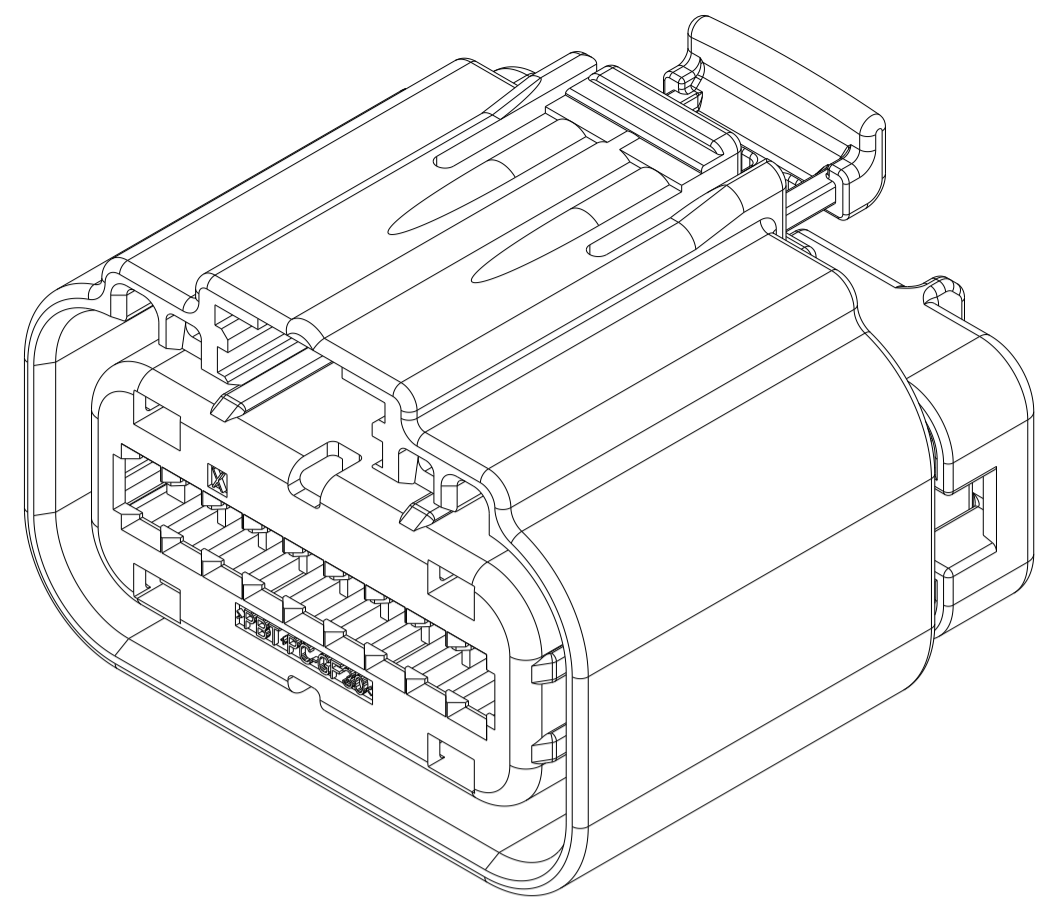
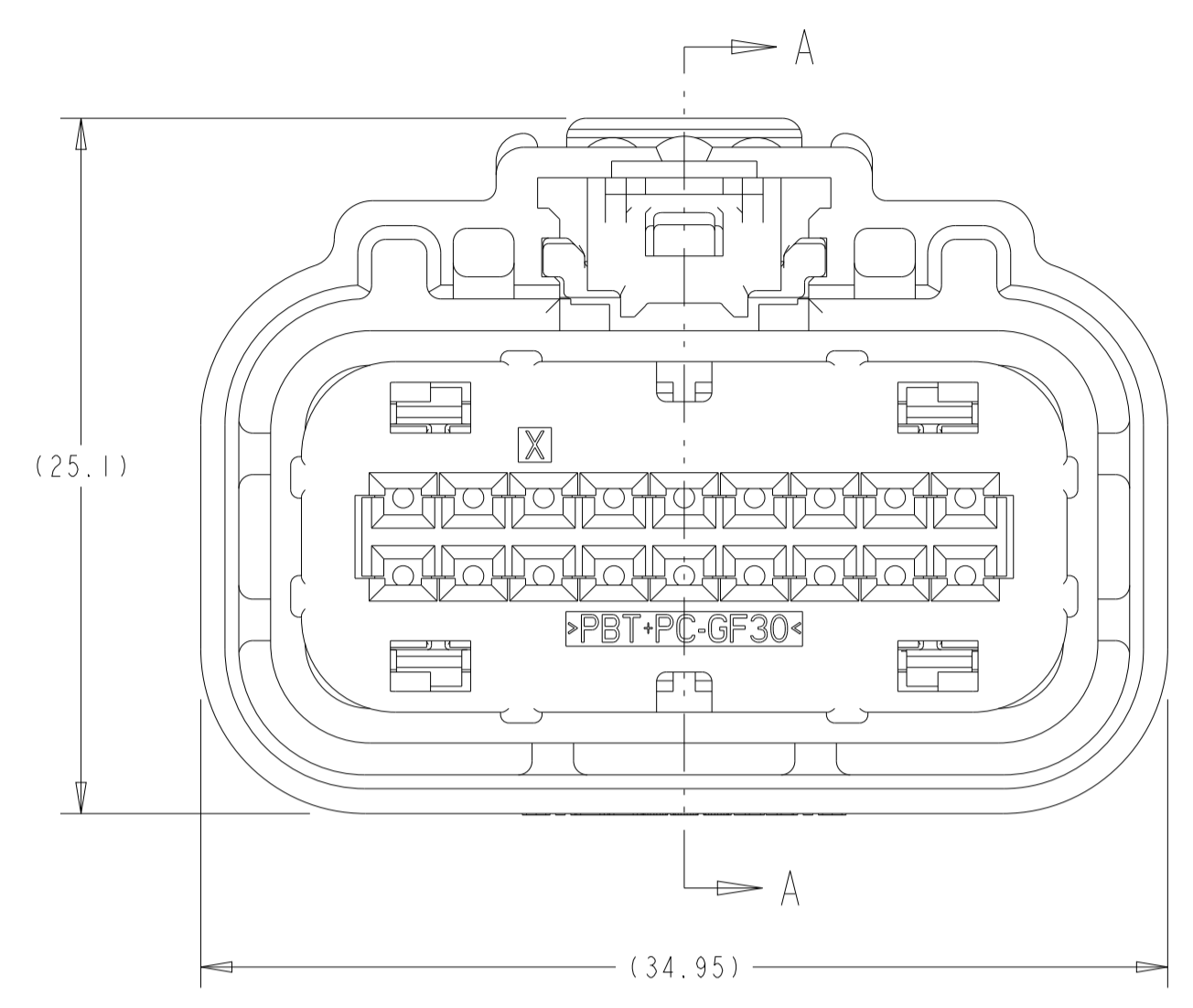

SCALE 3:1

- APPLICABLE TERMINAL PART NUMBERS (SOLD SEPARATELY):
 FOR TIN AND SILVER APPLICATIONS: 1393367 AND 1393366.
 FOR GOLD APPLICATIONS: 1393365 AND 1393364.
 FOR TERMINATION AND REELING OPTIONS
 SEE DRAWINGS 1393367, 1393366, 1393365, AND 1393364.
- COMPATIBLE WIRE SIZES FOR MAT SEAL DESIGN 1.19 TO 2.06 O.D.
 (22-18 AWG, 0.35-0.75 mm²).
- TPA IS SHIPPED IN PRE-LOADED POSITION. SOME TPA'S MAY BECOME FULLY SEATED DURING SHIPPING. USE TE INSTRUCTION SHEET 408-10128 TO REPOSITION TPA TO IT'S PRE-LOADED POSITION.
- TE ASSEMBLY PART NUMBER (X-XXXXXXX-X) AND TRACEABILITY CODE (YY = TWO DIGIT YEAR, JJJ = JULIAN DAY, HH = TWO DIGIT MILITARY HOUR) ARE PRINTED IN THIS LOCATION.
- APPLICABLE HEADER INTERFACE DRAWING 1488536 IS AVAILABLE UPON REQUEST. A COPY OF THIS DRAWING CAN BE OBTAINED FROM THE TE PRODUCT MANAGER, VIA YOUR TE SALES REPRESENTATIVE OR CUSTOMER SERVICE.
- ASSEMBLIES ARE BULK PACKAGED.
- OPTIONAL CPA IS SHIPPED IN IT'S PRE-LOADED POSITION.
- PART NOT RELEASED TO PRODUCTION.
- COMPANY LOGO AND MOLD CAVITY ID LOCATED ON THIS SURFACE.

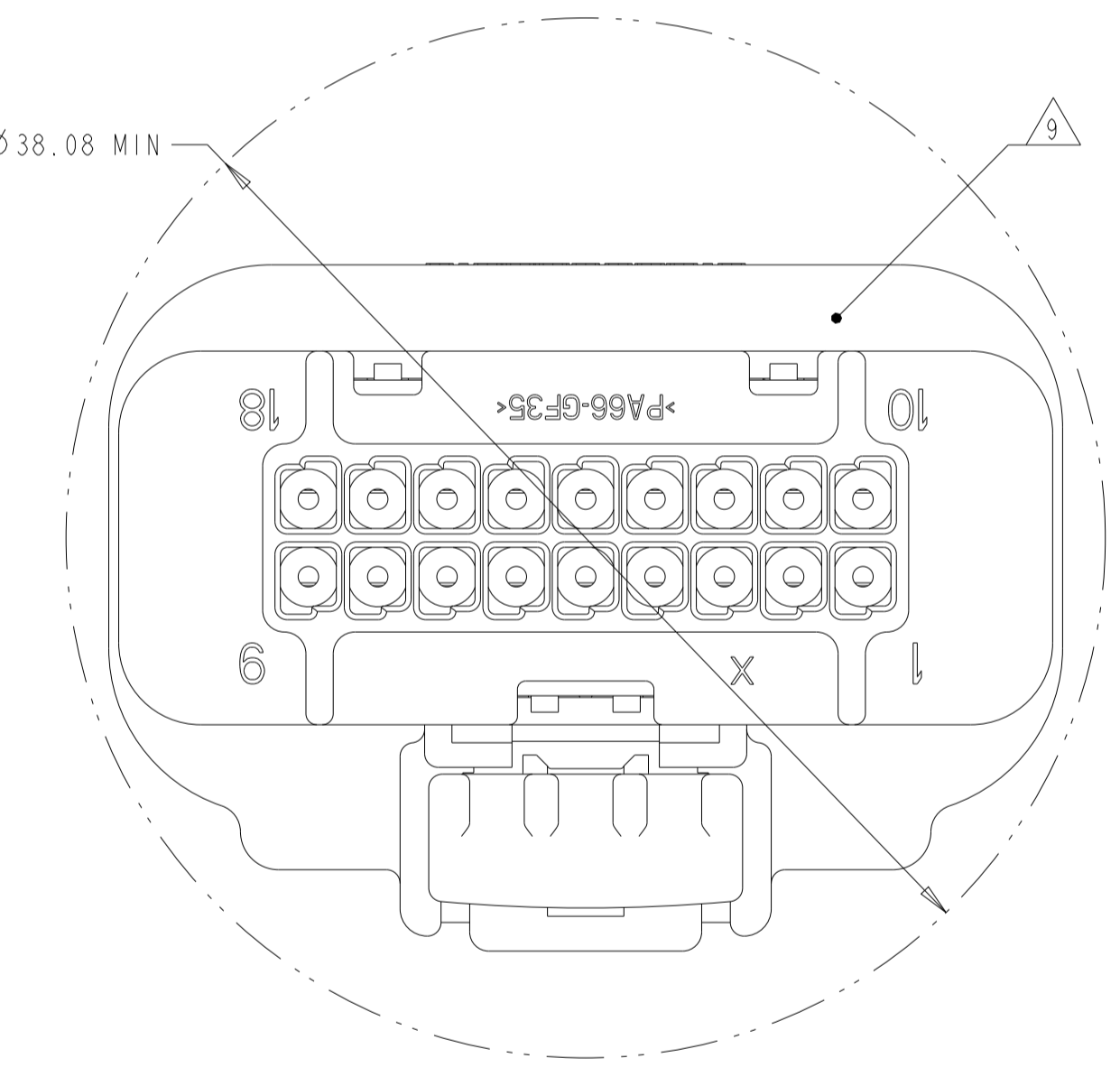
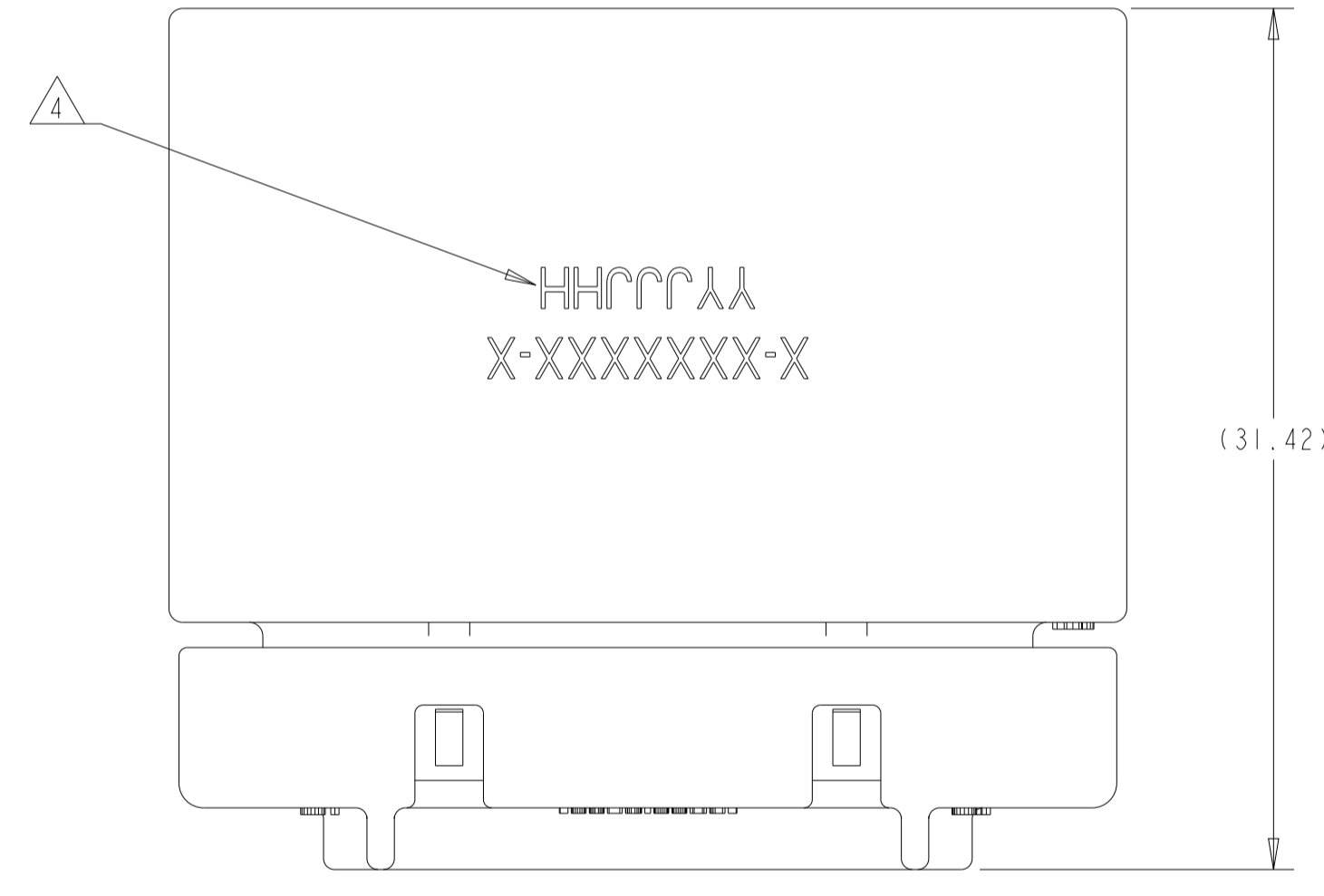

MINIMUM FEED THROUGH CONDITION
 WITH 1mm CLEARANCE ALL AROUND

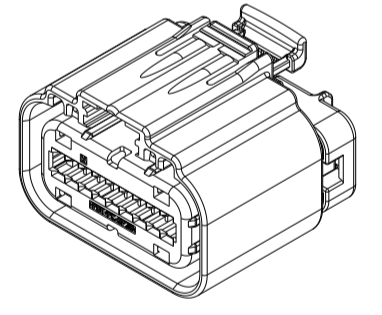

SCALE 1:1

KEYING OPTION "A" SHOWN
 SEE NOTE 5 FOR APPLICABLE
 HEADER INTERFACE INFORMATION

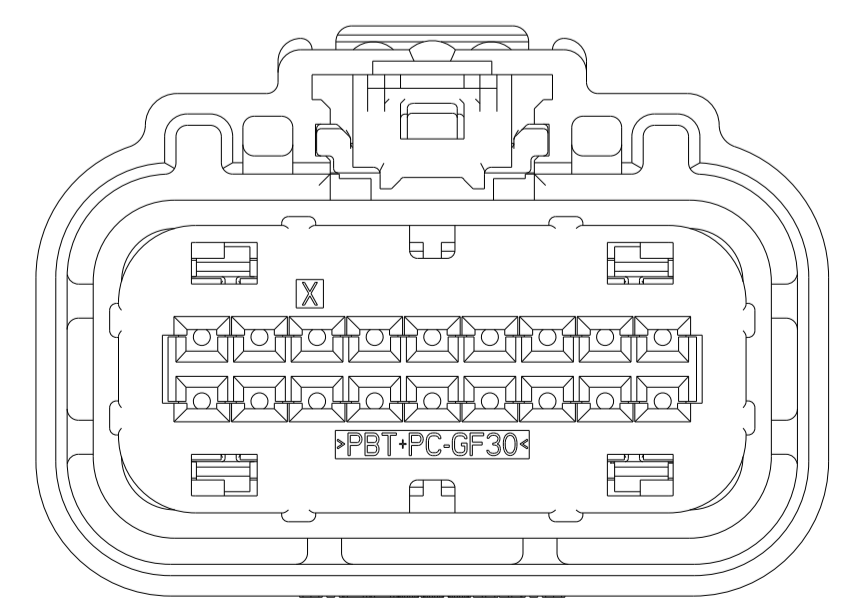

KEYING OPTION "A"
 HOUSING COLOR: BLACK
 SCALE 3:1

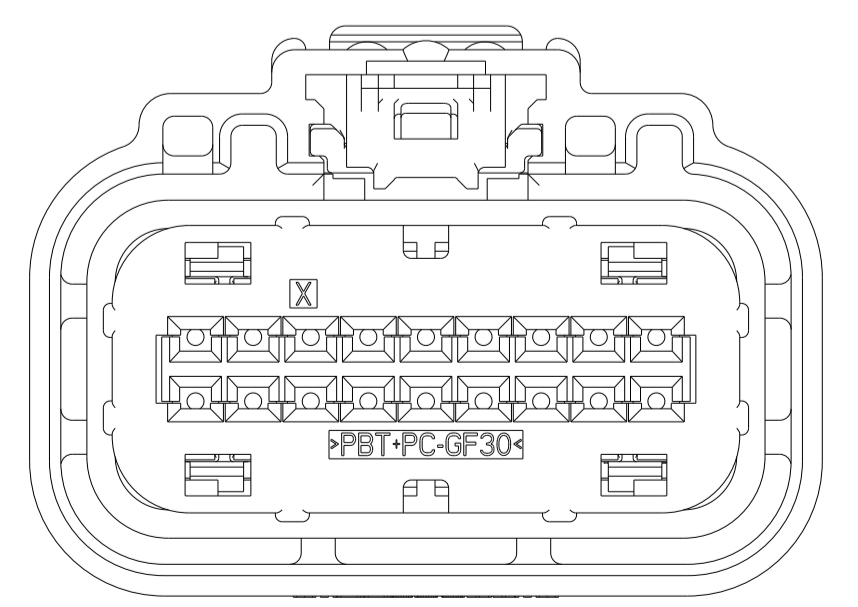

KEYING OPTION "B"
 HOUSING COLOR: GRAY
 SCALE 3:1

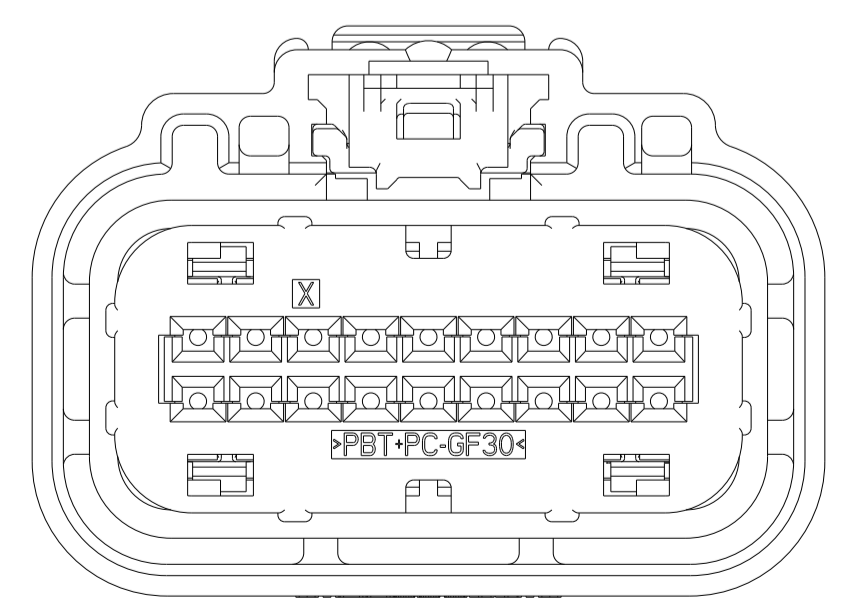

KEYING OPTION "C"
 HOUSING COLOR: BROWN
 SCALE 3:1

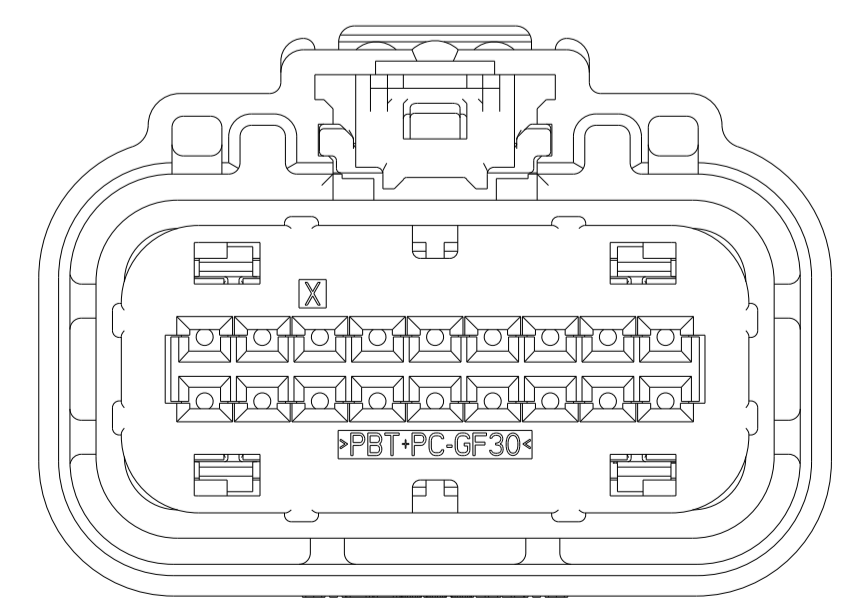

KEYING OPTION "D"
 HOUSING COLOR: GREEN
 SCALE 3:1

SEE SHEET 2 FOR BILL OF MATERIALS
 AND PINOUT CHART

THIS DRAWING IS A CONTROLLED DOCUMENT.		OWN: D. DRUMMOND 25FEB2013	TE Connectivity 2 X 9 SEALED, FEMALE PLUG ASSEMBLY
DIMENSIONS:		CHK: C. MARTIN 25FEB2013	
TOLERANCES UNLESS OTHERWISE SPECIFIED:		APVD: C. MARTIN 25FEB2013	
0 PLC ± 1 PLC ±0.3 2 PLC ±0.10 3 PLC ± 4 PLC ± ANGLES ±3° FINISH		NAME: 108-2282 APPLICATION SPEC	
MATERIAL: SEE TABLE		SIZE: 114-13150	RESTRICTED TO: A1
		WEIGHT: -	CAGE CODE: 00779
		CUSTOMER DRAWING	DRAWING NO: C=2203663
		SCALE: 3:1	SHEET 1 OF 2 REV: A8

