

THIS DRAWING IS UNPUBLISHED. RELEASED FOR PUBLICATION 20  
 © COPYRIGHT 20 BY TYCO ELECTRONICS CORPORATION. ALL RIGHTS RESERVED.

LOC	DIST	REVISIONS					
FT	0	P	LTR	DESCRIPTION	DATE	DWN	APVD
		A3		REVISED ECO-06-027517	28NOV2006	SW	CR
		A4		REVISED PER ECO-07-015282	28JUN2007	SS	CR
		A5		REVISED PER ECO-08-007356	25MAR2008	HMR	MS
		A6		REVISED PER ECO-08-009030	11APR2008	HMR	CR

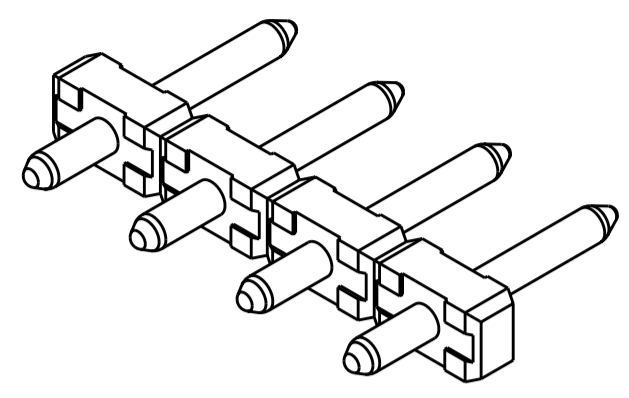

1546931-4 AS SHOWN

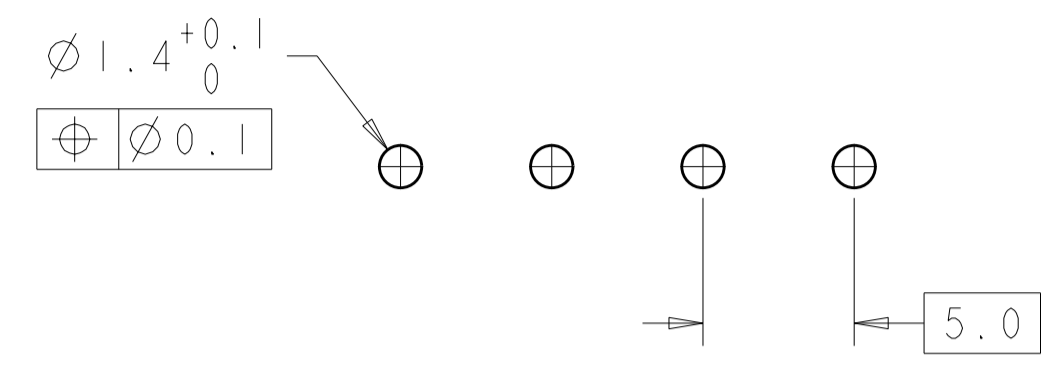
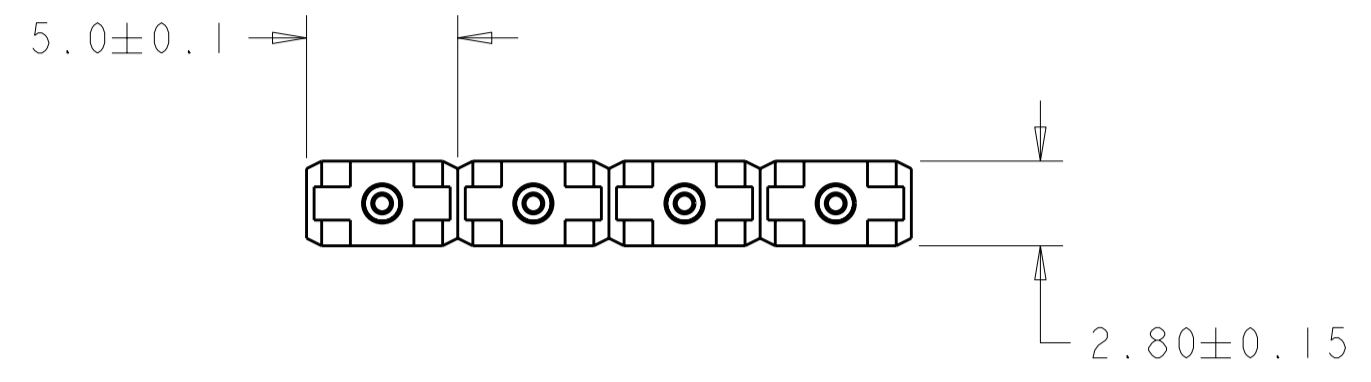

RECOMMENDED PC BOARD LAYOUT

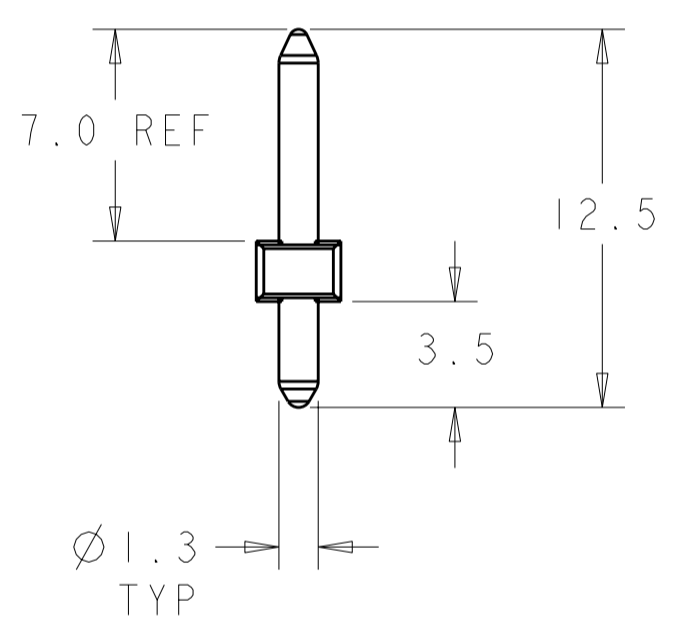
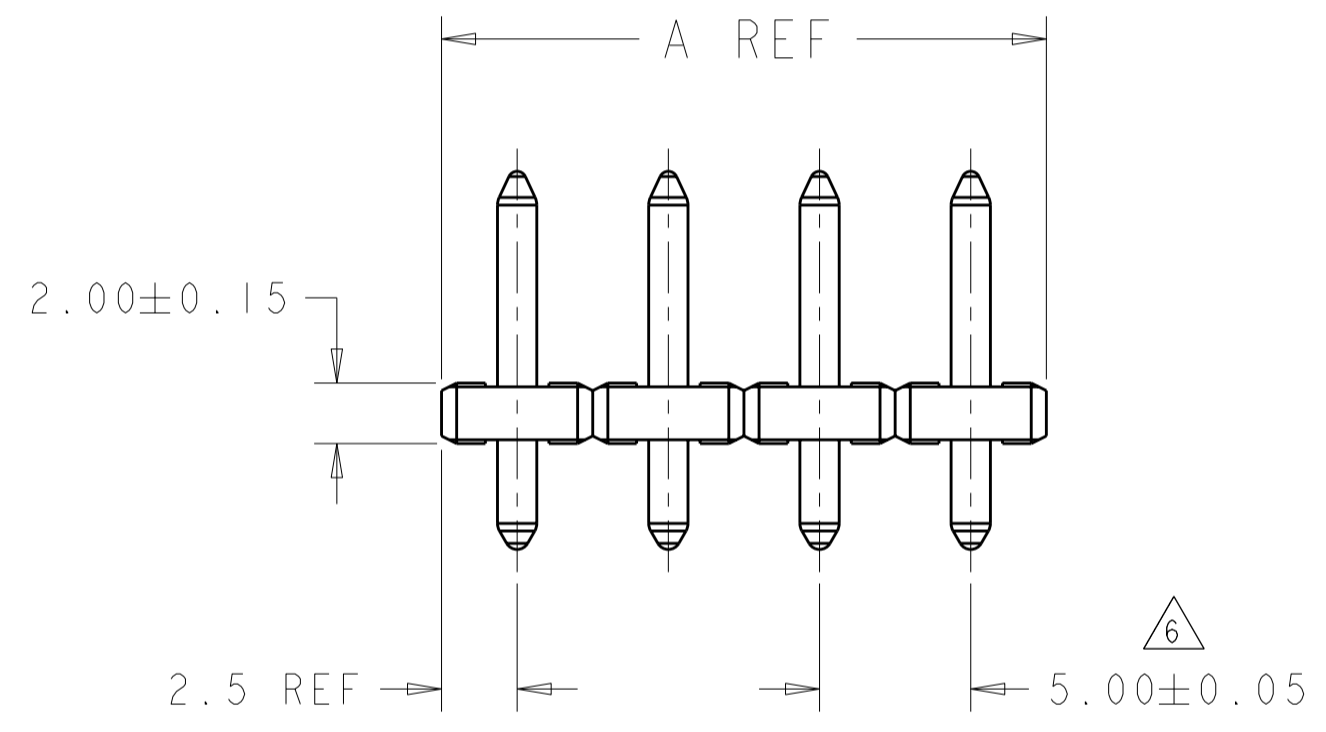

PRELIMINARY	TIN	TAPE AND REEL	15	3	3-1546931-2
PRELIMINARY	TIN	TAPE AND REEL	10	2	3-1546931-1
PRELIMINARY	0.254um GOLD	-	10	2	3-1546931-0
	TIN	TAPE AND REEL	25	5	2-1546931-9
	TIN	TAPE AND REEL	20	4	2-1546931-8
PRELIMINARY	TIN	TUBES	25	5	2-1546931-7
PRELIMINARY	TIN	TUBES	20	4	2-1546931-6
	TIN		125	25	2-1546931-5
	TIN		120	24	2-1546931-4
	TIN		115	23	2-1546931-3
	TIN		110	22	2-1546931-2
	TIN		105	21	2-1546931-1
	TIN		100	20	2-1546931-0
	TIN		95	19	1-1546931-9
	TIN		90	18	1-1546931-8
	TIN		85	17	1-1546931-7
	TIN		80	16	1-1546931-6
	TIN		75	15	1-1546931-5
	TIN		70	14	1-1546931-4
	TIN		65	13	1-1546931-3
	TIN		60	12	1-1546931-2
	TIN		55	11	1-1546931-1
	TIN		50	10	1-1546931-0
	TIN		45	9	1546931-9
	TIN		40	8	1546931-8
	TIN		35	7	1546931-7
	TIN		30	6	1546931-6
	TIN		25	5	1546931-5
	TIN		20	4	1546931-4
	TIN		15	3	1546931-3
	TIN		10	2	1546931-2
	PLATING	PACKAGING	A REF	NO OF POSN	PART NUMBER

1 MATERIALS AND FINISH:  
 HOUSING: PA 6-6, UL 94-V0, COLOR: BLACK.  
 TEMPERATURE RATING OF 260°C AT 1 MINUTE.  
 TERMINAL: BRASS, TIN PLATED.

2. SUITABLE FOR 1,6-2,4mm PC BOARD THICKNESS.  
 3. END-TO-END STACKABLE WITHOUT LOSS OF CENTERLINE SPACING.

4. RECOGNIZED UNDER THE COMPONENT PROGRAM OF UNDERWRITERS LABORATORIES INC. FILE N° E60677.

5. IMQ CERTIFICATE WITH SURVEILLANCE IN CONFORMITY WITH IEC 998-1/998-2-1.

6 NOT CUMULATIVE TOLERANCE.

THIS DRAWING IS A CONTROLLED DOCUMENT FOR TYCO ELECTRONICS CORPORATION. IT IS SUBJECT TO CHANGE AND THE CONTROLLING ENGINEERING ORGANIZATION SHOULD BE CONTACTED FOR THE LATEST REVISION.		DWN: S. WELDON 30 JAN 2004	Tyco Electronics Harrisburg, PA 17105-3608	
DIMENSIONS: mm		CHK: C. RICHARD 30 JAN 2004	NAME: TERMINAL BLOCK, PIN HEADER, UNSHROUDED, HIGH TEMPERATURE, 5.0mm PITCH	
TOLERANCES UNLESS OTHERWISE SPECIFIED:		APVD: C. RICHARD 30 JAN 2004	SIZE: A2 CAGE CODE: 00779 DRAWING NO: 1546931	
0 PLC ±.3		PRODUCT SPEC: 108-20166	RESTRICTED TO: -	
1 PLC ±.3		APPLICATION SPEC: 114-20079	SCALE: 4:1 SHEET 1 OF 1 REV A6	
2 PLC ±.25		WEIGHT: -		
3 PLC ±.		CUSTOMER DRAWING		
4 PLC ±.				
ANGLES ±2				
FINISH				