

# HIGH VOLTAGE CONTACTORS ECK200 SERIES - UP TO 500AMP

## INTRODUCTION

TE Connectivity's (TE) ECK200 series high-voltage DC contactor is designed for control in new energy applications. The ECK200 product line is a noteworthy and reliable solution for EV charging stations, solar inverters, battery energy storage systems, automated-guided vehicles (AGV) and electric forklifts. ECK200 is hermetically sealed with ceramic technology and enables high switching capability under 1000 VDC. The built-in PWM module design makes it smaller to save space.

## FEATURES

- Hermetically sealed with ceramic technology
- Designed with built-in economizer, hold power 1.7 W
- 500A carry current capability (see cautions)
- Maximum DC breaking current at 2000 A
- Maximum DC breaking voltage at 1000 VDC
- Auxiliary contact version available
- Comply with DC-1 utilization category in IEC60947-4-1

## APPLICATIONS

- DC charging stations
- Electric vehicles
- AGV
- Electric forklifts
- Energy storage systems
- Photovoltaic inverters
- DC converters
- Battery protection boards

## APPROVALS

- CE: 724-00004
- UL: E82292
- TUV: R50571784
- CCC approved

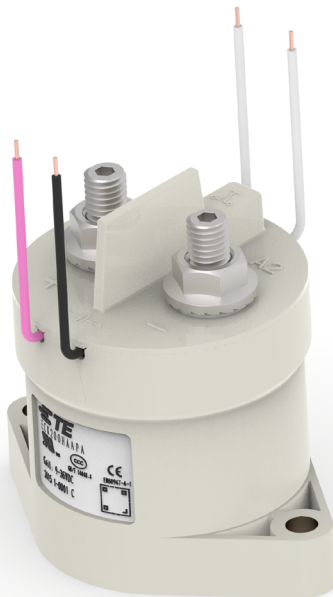

# High Voltage Contactors ECK200 Series

## CONTACT DATA

Contact current	500 A
Maximum Switching voltage	1000 VDC
Contact arrangement	1 Form X (SPST-NO-DM)
Initial contact resistance	≤ 0.4 mΩ (200 A, after 1 minute)
Operating time, maximum (At 23°C)	30 ms
Release time, maximum (At 23°C)	10 ms
Mechanical life	
With auxiliary contact	500,000 cycles
Without auxiliary contact	500,000 cycles

## CONTACT RATINGS

Load	Cycles
200A, 450VDC, make/break, resistive	6000
200A, 1000VDC, make/break, resistive	1000

### Note:

- Only typical rating listed, please refer to make/break curves on the next page for more details at different current and voltage.

## OTHER DATA

Material compliance: EU RoHS/ELV, China RoHS, REACH, and for halogen content refer to the product compliance support Center at <a href="http://www.te.com/customer-support/rohssupportcenter">www.te.com/customer-support/rohssupportcenter</a>	
Ambient temperature	-40 °C to 85 °C
Vibration resistance (functional)	Sine, 10-2000 Hz, 6G
Shock resistance (functional)	11ms 1/2 Sine, Peak 20G
Terminal type	Screw for contact, wire for coil
Weight	380g
Packaging/Unit	Box/24 pcs.

## COIL VERSIONS, DC COIL

Coil Code	Nominal Voltage	Nominal Operating Current	Max Starting Current	Operating Voltage	Maximum Operating Voltage	Release Voltage	Coil Power
A	9 VDC ~ 36 VDC	0.13 A @ 12 VDC 0.07 A @ 24 VDC	3.6 A	≤9 VDC	36 VDC	≥3 VDC	Start: 27.7 W Hold: 1.7 W

All figures are given for coil without pre-energization, at ambient temperature +23°C.

## CE DECLARATION (IEC60947-4-1)

Rated Operational Current	Utilization Category	Switching Cycles
100A	DC-1	6,050

## AUXILIARY CONTACT DATA

Contact form	1 Form A (SPST-NO)
Contact current, maximum	2 A, 30 VDC
Contact current, minimum	10 mA, 24 VDC
Contact resistance, maximum	0.4 Ω @ 30 VDC

## INSULATION DATA

<b>Dielectric Withstand Voltage (leakage current &lt;1mA)</b>	
Between open main contacts	4300 Vrms
Between main contact and coil	4300 Vrms
Between main contacts and auxiliary contacts	4300 Vrms
Between open auxiliary contacts	750 Vrms
<b>Initial Insulation Resistance @ 1000VDC</b>	
Between insulated elements	> 1x10 <sup>9</sup> Ω

# High Voltage Contactors ECK200 Series

## CURRENT CARRYING CAPABILITY CURVE

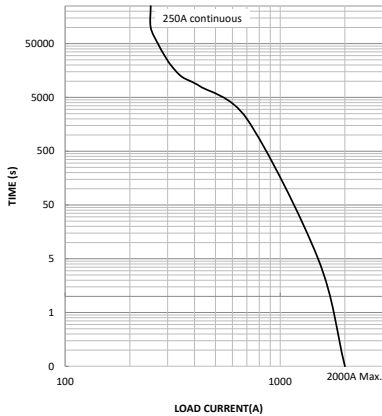

### Notes:

- The data is measured at the environment temperature 85 °C with cross section area of wire 150mm<sup>2</sup> minimum. Smaller cable cross section wires are also allowed depending on the end users thermal conditions.
- For 500A current, recommend >202 mm<sup>2</sup> conductor size and please users select the appropriate connection conductor cross section or active cooling to control the temperature. Keep main contact terminals @130 °C max for long-term continuous carry, @140 °C max for two hours.

## DIMENSIONS

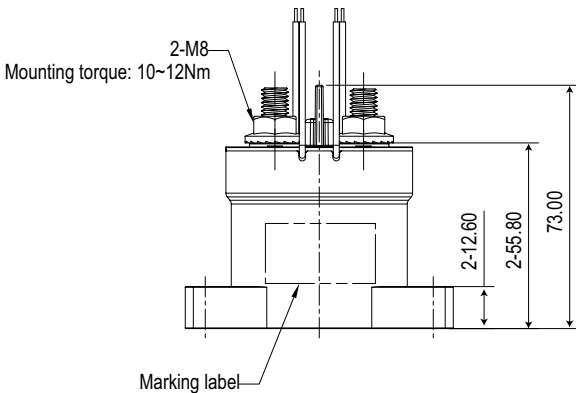
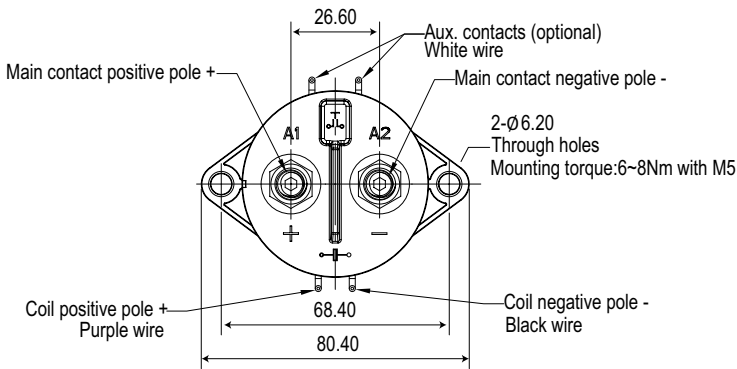

### Note:

- Main contact terminal connection and coil connection with positive and negative difference.

## ESTIMATED MAKE & BREAK POWER SWITCHING RATINGS

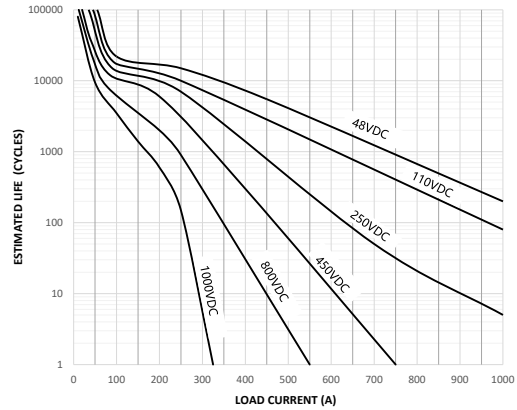

### Notes:

- The curve was created based on extrapolated data with few typical points, users are recommended to confirm performance in actual application.
- The typical data were estimated with resistive load at room temperature.

## CIRCUIT DIAGRAM

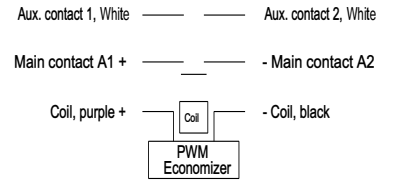
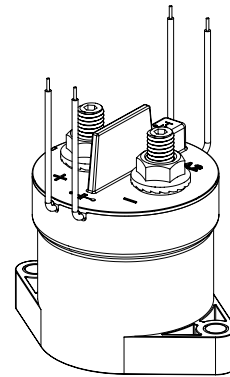

UL3266 20AWG  
Lead wire length customized  
Standard 310 ±10

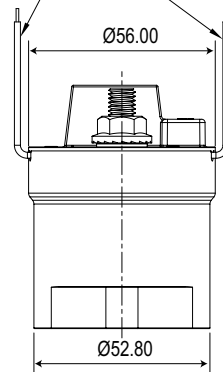

General Tolerance	
Dimension	Tolerance
<10	±0.3
10 - 50	±0.6
>50	±1.0

## ORDERING INFORMATION

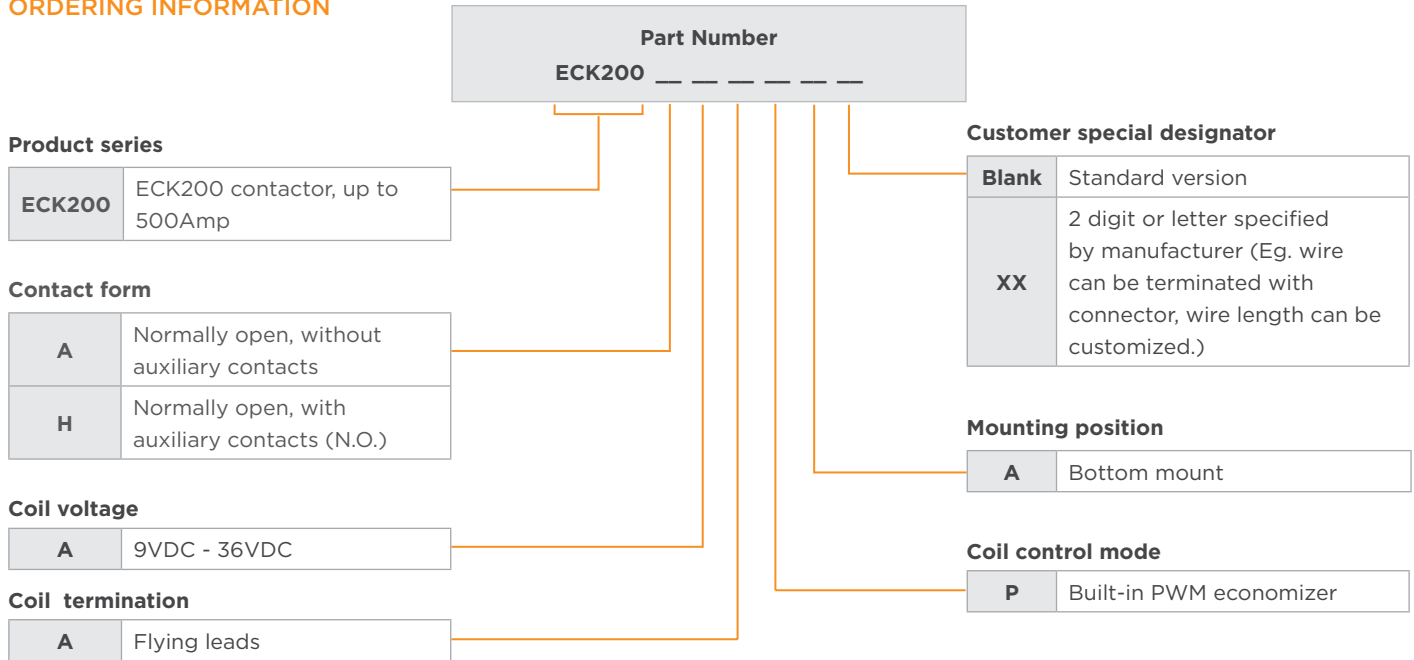

## PRODUCT PART NUMBER TABLE

Product code	Contact form	Mounting position	Coil	Coil control mode	Part number
ECK200AAAPA	Normally open, without auxiliary contacts	Bottom	9VDC - 36VDC	Built-in PWM economizer	<u>1-2071567-2</u>
ECK200HAAPA	Normally open, with auxiliary contacts (N.O.)				<u>1-2071567-1</u>

Note: Only typical part numbers are listed above, other types please contact TE engineer.

## CAUTIONS

- Do not use the product when product is dropped or broken.
- Avoid mounting the contactor with the main contact screw terminals in downward direction, otherwise the contactor performance will not be achieved.
- Please use correctly according to the mark on the surface of the product. Main contact terminals and coil wires have polarity difference. When the connection polarity is reversed, the electrical characteristics promised in the datasheet will not be guaranteed.
- There are diodes built in the PWM economizer of the coil inside the contactor, additional diodes are not required.
- Please consider electromagnetic interference when using the product.
- Screw locking torque of main contact terminals should be 10 N·m - 12 N·m for M8 screw. Screw locking torque of product bottom mounting should be 6 N·m - 8 N·m for M5 screw.
- Suitable for applications under Uimp 6kV.

## te.com

©2024 TE Connectivity Plc. All Rights Reserved.

TE Connectivity, TE, TE connectivity (logo) and EVERY CONNECTION COUNTS are trademarks owned or licensed by the TE Connectivity plc. family of companies. All other logos, products and/or company names referred to herein might be trademarks of their respective owners.

While TE has made every reasonable effort to ensure the accuracy of the information in this document, TE does not guarantee that it is error-free, nor does TE make any other representation, warranty or guarantee that the information is accurate, correct, reliable or current. TE reserves the right to make any changes to the information contained herein without prior notice. TE Connectivity assumes only those obligations set forth in the terms and conditions for this product and shall in no event be liable for any incidental, indirect, or consequential damages arising out of the sale, resale, use, or misapplication of the product. TE expressly disclaims any implied warranties with respect to the information contained herein, including, but not limited to, implied warranties of merchantability or fitness for a particular purpose. Dimensions, specifications and/or information contained herein are for reference purposes only and are subject to change without notice. Consult TE for the latest dimensions, specifications and/or information. Users of TE Connectivity products must make their own assessment as to whether the respective product is suitable for the respective desired application.

12/24 ED