

ARISO CONTACTLESS COUPLER



TE Connectivity Germany GmbH
Pfnorstrasse 1
64293, Darmstadt
Germany
Tel.: +49 (0) 6151 607 0
Fax: +49 (0) 6151 607 1223
www.te.com
[Link to ARISO Products in TE.com](#)



1. GENERAL

1.1 Part Numbers (PNs), Models, Applicable Documents and Model's Explanation

The following set of documents, in its entirety, describes the product

Version	Part Number	Model	Document #	Document Title
GPIO	PN 2287598-1	TXM030S012PNP2A	DS 116-19004 AS 114-19159 TS 109-19040 PS 108-19484	Datasheet (this document) Application Specification Test Specification Product Specification
	PN 2287598-2	RXM030S012PNP2A		
	PN 2287598-3	TXM030S012PNP8A		
	PN 2287598-4	RXM030S012PNP8A		
	PN 2287598-5	RXM030S012PNP8B		
IO-Link	PN 2287598-7	TXM030S012IOL2A	DS 116-19006 AS 114-94474 TS 109-18361 PS 108-94597	Datasheet Application Specification Test Specification Product Specification
	PN 2287598-8	RXM030S012IOL2A		
GPIO and IO-Link			TEC 109-1 107-18120 WS 101-18013 C-2287598	General Requirements for Testing Packaging Specification Workmanship Specification Customer Product Drawing

Explanation of the Models' Characters

GPIO and IO-Link	TX / RX	Power Transmitter / Receiver
	M	Form Factor: M = Circular
	030	Housing Diameter: 30mm
	S	Product Type: S = Standard
GPIO	012	Power Level at RX Input: 12W
	PNP	Internal Logic: PnP
	2 or 8	Number of PNP Signal Channels (GPO for the TX and GPI for the RX)
IO-Link	A or B	Wiring Pinout Options: A or B = arbitrary names for different cases
	IOL	Internal Logic: IO-Link
	2	Number of Digital Channels (C/Q and DI/DO)
	A	Wiring Pinout Option: A = arbitrary name



This ARISO product contains PowerbyProxi™ wireless power technology



1.2 Design and Construction

Product shall be of the design, construction and physical dimensions specified on the applicable Customer Product Drawing and Product Specification.

The following versions are available for the ARISO GPIO Contactless Connectivity Product:

M30, 4 pins, 2 PNP channels:

- ARISO TXM030S012PNP2A - Power Transmitter / Data Receiver⁽¹⁾
- ARISO RXM030S012PNP2A - Power Receiver / Data Transmitter⁽¹⁾

M30, 12 pins, 8 PNP channels:

- ARISO TXM030S012PNP8A - Power Transmitter / Data Receiver⁽¹⁾
- ARISO RXM030S012PNP8A - Power Receiver / Data Transmitter⁽¹⁾

Optimized for connection to distribution boxes PNs: 2273161-1 (S1 only), 2273146-1, 2273139-1 and 2273134-1.

ARISO RXM030S012PNP8B - Power Receiver / Data Transmitter⁽¹⁾

Optimized for connection to distribution box PN 2273161-1 (S2 supported at sockets 1 and 2, sockets 7 and 8 not connected).

- Note (1) The nomenclature “Data Transmitter / Data Receiver” refers only to the Data Channels.
The TX and the RX exchange continuously acknowledgment signals (intrinsic internal data transmission) in both directions for a stable communication. TX and RX are Transceivers regardless of the external data transmission.

1.3 Features

The product has the following features:

Power Input Reverse Polarity Protection

The product switches off if the power supply connected to the TX has wrong polarity.

Power Output Short Circuit Protection / Data Output Short Circuit Protection

The product switches off the power / data if the outputs are short circuited or if the load is above specification.

Data Input / Output Reverse Polarity Protection

The product is protected against reversed connections of the data inputs and data outputs.

Over Temperature Protection (OTP)

The product switches off if the temperature becomes too high.

Foreign Object Protection (FOP)

The product switches off if metal is present between Power Transmitter and Power Receiver.

Dynamic Pairing

Any ARISO TX can pair with any ARISO RX.
See paragraph 5.6 for a Cross Wiring Pinout.

Status OK / In Operating Range Indication

The ARISO TX has two status signals indicating either Normal Operation or Incorrect Behavior (like Over Temperature or Presence of a Foreign Object).



1.4 Characteristics overview

Power Transfer Capability	12.0W on RX side towards its load (sensor), Ambient Temperature 55°C Maximum distance between TX and RX: 7.0mm
Number of Digital GPIO Channels	TX PN 2287598-1 and RX PN 2287598-2 have 2 PNP Digital GPIO Channels TX PN 2287598-3 and RX PN 2287598-4/-5 have 8 PNP Digital GPIO Channels
TX LED Color	Yellow (570nm ≤ λ ≤ 590nm)
TX LED Brightness	min. 3 mcd (possible reduction through the lens cap)

1.5 Mechanical Data

See Customer Product Drawing for full details.

Parameter	Value	Units	Conditions
Max. Tightening Torque	40	N·m	-
M12 Connector Minimum Torque for IP67	0,6	N·m	-
Max. Cable Pulling Force	50	N	1 minute
Maximum TX Weight	155	g	Cable included
Maximum RX Weight	150	g	Cable included
Dimensions TX	See Customer Product Drawing		
Dimensions RX	See Customer Product Drawing		

1.6 Environmental Data

Parameter	Value	Unit	Condition
Min. Ambient Temperature	-20	°C	Operational
Max. Ambient Temperature	+55	°C	Operational
OTP Threshold	+65	°C	-
Max. Ambient Temperature	+75	°C	Powered, Non-Operational
Max. Ambient Storage Temperature	+100	°C	-
Ingress Protection	IP67	-	-
Mechanical Shock	30	g	Acc. EN/IEC 60512-6-3 (see PS §1.1)
Mechanical Vibration	0.01	g ² /Hz	Acc. EN/IEC 60512-6-4 (see PS §1.1)
Free Fall Test	1	m	Acc. IEC 60512-5 (see PS §1.1)
Rapid Temperature Change	-25 to +80	°C	Acc. EN/IEC 60068-2-14 (see PS §1.1)
Damp Heat, cyclic	21 cycles		Acc. IEC 60512-11-12 (see PS §1.1) Lower Air Temperature: 25°C ± 3°C. Upper Air Temperature: 55°C ± 2°C. 90-100% Relative Humidity. Duration of cycles: 12+12 hours.
Dry heat	+80	°C	Acc. EN/IEC 60512-11-9 (see PS §1.1)



Parameter	Value	Unit	Condition
Flowing Mixed Gas Corrosion	-	-	Acc. EN/IEC 60512-11-7 (see PS §1.1)
Electrostatic Discharge	8 / 4	kV	Acc. EN/IEC 61000-4-2 (see PS §1.1) Pass Criterion: B Air / Contact Discharge
Radiated EM Field Immunity	10	V/m	Acc. EN/IEC 61000-4-3 (see PS §1.1) Freq. Range: 80-1000 MHz
Fast Transient Immunity	$\pm 1 / \pm 2$	kV	Acc. EN/IEC 61000-4-4 (see PS §1.1) Data / Supply Lines
Surge Immunity	± 2	kV	Acc. EN/IEC 61000-4-5 (see PS §1.1) Supply lines to ground. Pass Criterion B.
Immunity to Conducted Disturbances	10	V _{RMS}	Acc. EN/IEC 61000-4-6 (see PS §1.1) Pass Criterion A.
Power Frequency Magnetic Field Immunity	30	A/m	Acc. EN/IEC 61000-4-8 (see PS §1.1) Pass Criterion A

2. POWER LINK

2.1 Power Input

Parameter	Value	Unit	Condition
TX Input Voltage	24.0	V _{DC}	Tolerance: $\pm 10\%$
Maximum TX Input Current	0.75	A	-
Maximum TX Standby Power	1.0	W	Unmated
	4.0	W	Mated
Maximum TX Inrush Current	1.4	A	-
Reverse Polarity Protection	Yes	-	-
Foreign Object Protection	Yes	-	-
Under-Voltage Lockout (UVL)	20.3	V	-
UVL Hysteresis	0.1	V	-



2.2 Power Output

2.2.1 General

Parameter	Value	Unit	Condition
RX Output Voltage	24.0	V _{DC}	Tolerance: ±5%
RX Continuous Output Power	12.0	W	Maximum Axial Distance TX-RX: 7.0 mm
RX Peak Output Power	12.5	W	No Misalignment
RX Max. Output Ripple & Noise	480	mV	-
Operational Readiness (Power <i>and</i> Data)	160 ⁽¹⁾	ms	RX Power <i>and</i> Data are ready at full load when TX is switched on.
Operational Readiness (Data only)	25 ⁽²⁾	ms	TX Data are ready after RX Power is ready. Take the startup time of the sensor into account.
Short Circuit Protection	Yes	-	-
Can handle an Output Inrush Current up to	200	µA/s	2A during 100µs 10A during 20µs
Output Short Circuit Current	0.65	A	-
Over Temperature Protection	Yes	-	-
Maximum Axial Distance	7	mm	Misalignment 0mm
Maximum Misalignment	5	mm	-
Maximum Tilt	30	°	-
Rotational Invariance or Rotational Freedom	1250 ⁽³⁾	rpm	-
Minimum Inter Coupler Distance	60	mm	-
Minimum Metal Clearance in XY Direction	15	mm	-
Minimum Metal Clearance in Z Direction	10	mm	-

Note (1): the TX and the RX are already near each other before the TX is powered up

Note (2): the TX is powered up without RX. After a RX is put near the TX, the RX needs the time written to provide stable Data Outputs.

Note (3): Tested at another version



2.2.2 Maximum Power over Distance

Distance d “cap-to-cap” between RX and TX [mm]	Output Power [W]
0.0	12.0
2.0	12.0
4.0	12.0
6.0	12.0
7.0	12.0

2.2.3 Maximum Power over Misalignment

Distance / Misalignment / Tilt $\Delta z / \Delta r / \Delta \Omega$ [mm / mm / °]	Output Power [W]
0.0 ±5.0 0.0	12.0
2.0 ±5.0 0.0	12.0
2.0 0.0 7.5	12.0
2.0 ±5.0 8.5	12.0
4.0 ±5.0 0.0	12.0
4.0 0.0 15.0	12.0
4.0 ±5.0 17.5	12.0
5.0 ±3.0 0.0	12.0
5.0 0.0 20.0	12.0
5.0 ±3.0 22.5	12.0
7.0 ±2.0 0.0	12.0
7.0 0.0 25	12.0
7.0 ±2.0 32.5	12.0

3. DATA LINK

3.1 GPI, General Purpose Digital Inputs (PNP) at RX side

Parameter	Value	Unit
Maximum Input Voltage	36	V
Minimum Input Voltage	-1	V
Minimum Input High Level	8	V
Maximum Input Low Level	5	V
Input Load current	< 4.5	mA
Maximum switching frequency through cables	500	Hz

3.2 GPO, General Purpose Digital Output (PNP) at TX side

Parameter	Value	Unit	Condition
Number of Channels	8	-	-
RX Maximum Output Voltage	24	V	Equal to Input Voltage.
RX Minimum Output Voltage	0	V	-
Output Stage Type	PNP	-	-
Max. Impedance High	4	Ω	-
Min. Impedance Low	1	M Ω	-
Maximum Output Current	250	mA	Tolerance: $\pm 20\%$ Overcurrent protected, see note below.
Maximum Delay + Jitter	800	μ s	Single channel

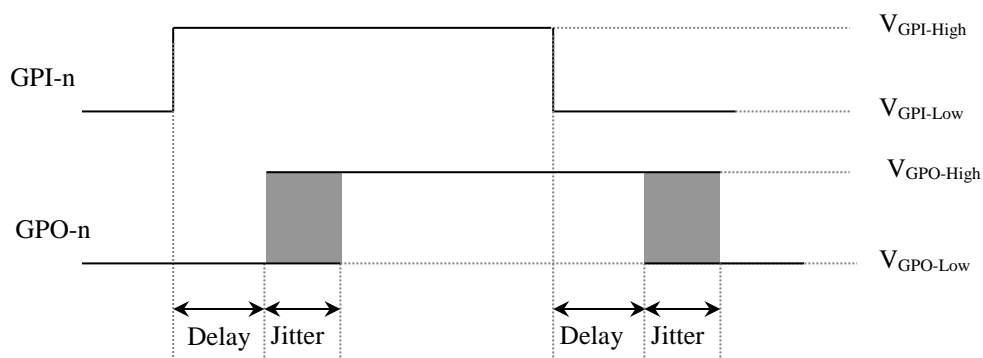

Figure 3.2.1 – Definition of Delay and Jitter for DI/DO data link

Note: All digital outputs are over-current protected, the total sum of all currents from GPIO-1 to GPIO-8, FOD and Status NOK cannot be larger than specified.



4. IN OPERATING RANGE / STATUS INDICATION

The ARISO Transmitter (TX) has two status signals indicating the status of operation. These two signals, Status_NOK (Not OK) and FOD (Foreign Object Detection), indicate the followings:

State Description	FOD level	Status_NOK Level	LED	Notes
TX powered RX not present	Low	High	10Hz blinking	TX not paired
TX powered RX paired with TX	Low	Low	Continuously On	System in operating range and in normal operation
TX powered RX paired with TX	Low	High	10Hz blinking	System error e.g.: Over temperature RX obstructed by Foreign Object
TX powered RX paired with TX	High	High	1Hz blinking	System error e.g.: Too high power due to FOD

5. CONNECTOR INTERFACES FOR TX AND RX

Both the TX and RX are equipped with a standard A-Coded 12-Pins or 4-Pins M12 connector: male for the TX and female for the RX. For the mechanical outline, see Customer Product Drawing.

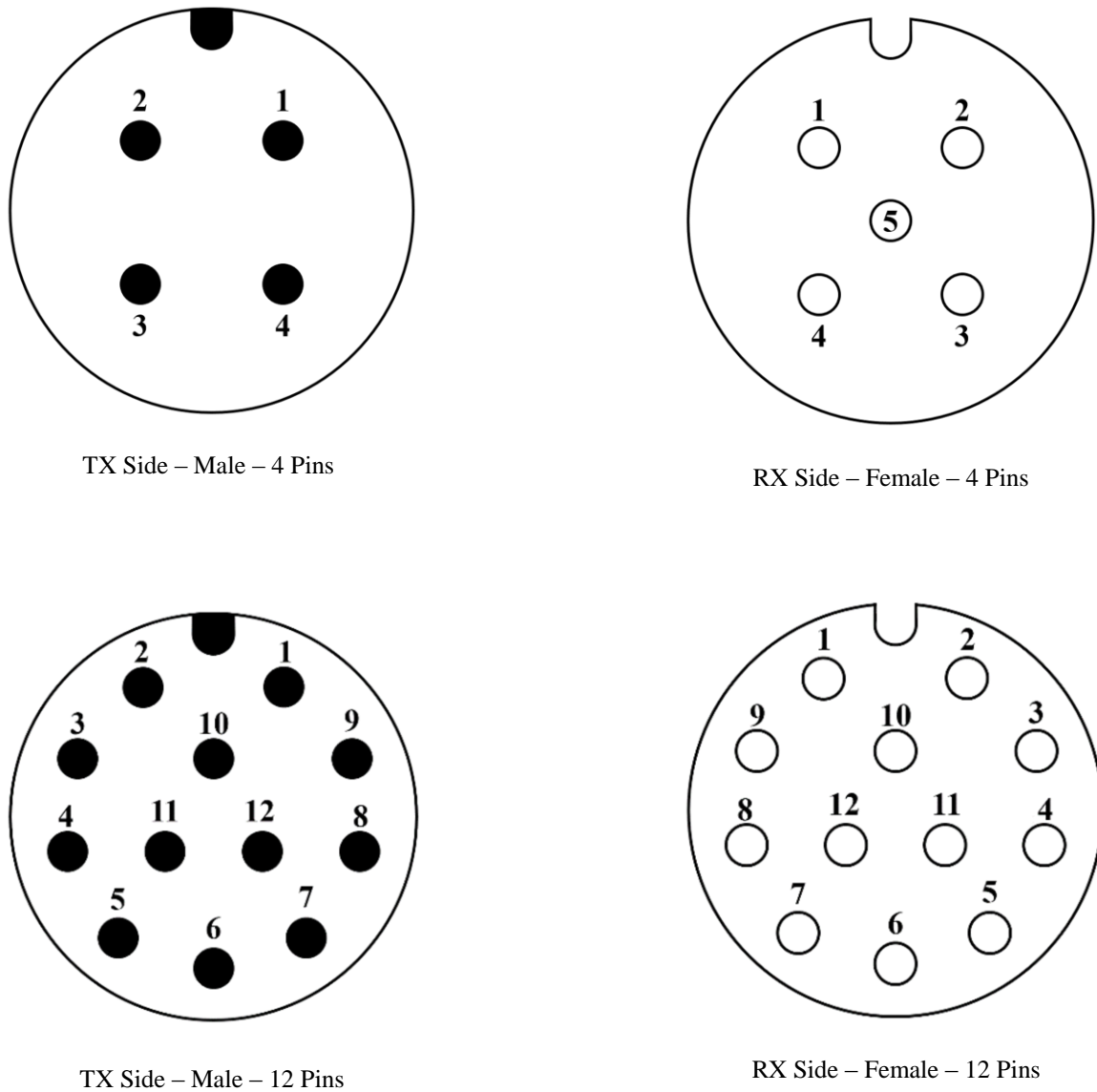

Figure 5.1 – TX and RX mating connector interfaces



5.1 Wiring Pinout for the TX PN 2287598-1 (TXM030S012PNP2A – 4 Pins)

Position Number	Signals
1	+24V _{DC}
2	GPO-1
3	Ground
4	GPO-2

5.2 Wiring Pinout for the TX PN 2287598-3 (TXM030S012PNP8A – 12 Pins)

Position Number	Signals	Comment
1	+24V _{DC}	This Wiring Pinout fits to the following TE Connectivity distribution boxes: PN 2273134-1 PN 2273139-1 PN 2273146-1 PN 2273161-1
2	Ground	
3	GPO-1	
4	GPO-2	
5	GPO-3	
6	GPO-4	
7	GPO-5	
8	GPO-6	
9	GPO-7	
10	GPO-8	
11	FOD (Foreign Object Detection)	
12	Status_NOK (Status Not OK)	



5.3 Wiring Pinout for the RX PN 2287598-2 (RXM030S012PNP2A – 4 Pins)

Position Number	Signals
1	+24V _{DC}
2	GPI-1
3	Ground
4	GPI-2
5	Not Connected

5.4 Wiring Pinout for the RX PN 2287598-4 (RXM030S012PNP8A – 12 Pins)

Position Number	Signals		Comments
1	+24V _{DC}	-	This Wiring Pinout fits to the following TE Connectivity distribution boxes: PN 2273134-1 PN 2273139-1 PN 2273146-1 PN 2273161-1 (only 8xS1 of the Distribution Box Sockets).
2	Ground	-	
3	GPI-1	S1 Socket 1	
4	GPI-2	S1 Socket 2	
5	GPI-3	S1 Socket 5	
6	GPI-4	S1 Socket 3	
7	GPI-5	S1 Socket 7	
8	GPI-6	S1 Socket 4	
9	GPI-7	S1 Socket 6	
10	GPI-8	S1 Socket 8	
11	Not connected	-	
12	Not connected	-	



5.5 Wiring Pinout for the RX PN 2287598-5 (RXM030S012PNP8B – 12 Pins)

Position Number	Signals		Comments
1	+24V _{DC}	-	This Wiring Pinout fits to the TE Connectivity distribution box PN 2273161-1 (S2 at Sockets 1 and 2 is supported but Sockets 7 and 8 are not working).
2	Ground	-	
3	GPI-1	S1 Socket 1	
4	GPI-2	S1 Socket 2	
5	GPI-3	S1 Socket 5	
6	GPI-4	S1 Socket 3	
7	Not connected	-	
8	GPI-5	S1 Socket 4	
9	GPI-6	S1 Socket 6	
10	Not connected	-	
11	GPI-7	S2 Socket 1	
12	GPI-8	S2 Socket 2	

5.6 Cross Wiring Pinout for pairs using TX and RX with different numbers of pins

TX with 4 pins can be coupled with RX with 12 pins and TX with 12 pins can be coupled with RX with 4 pins using the following correspondence among the pins:

TX		RX	
Part Number	Pin # – Channel	Pin # – Channel	Part Number
PN 2287598-1 4 Pins (2 Channels)	2 – CH1	6 – CH4	PN 2287598-4 12 Pins (8 Channels) Pin Coding Version A
	4 – CH2	7 – CH5	
PN 2287598-1 4 Pins (2 Channels)	2 – CH1	6 – CH4	PN 2287598-5 12 Pins (8 Channels) Pin Coding Version B
	4 – CH2	8 – CH5	
PN 2287598-3 12 Pins (8 Channels)	6 – CH4	2 – CH1	PN 2287598-2 4 Pins (2 Channels)
	7 – CH5	4 – CH2	

6. TE CONNECTIVITY DISTRIBUTION BOXES COMPATIBLE WITH THE SPECIFIED ARISO PRODUCTS

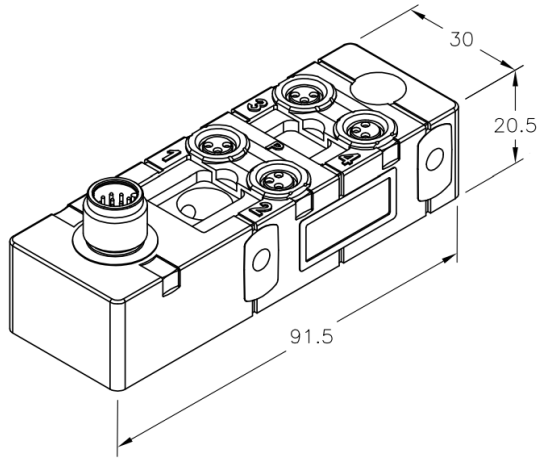

PN 2273134-1

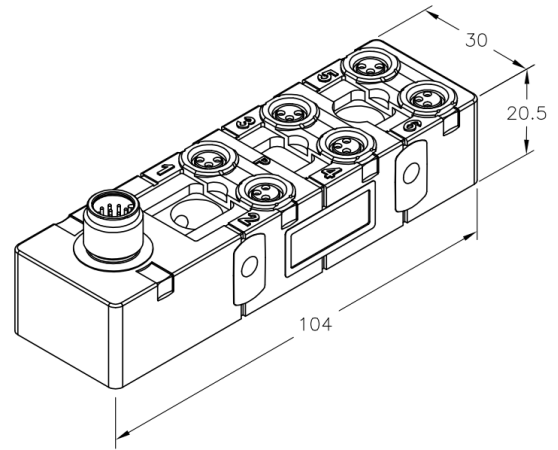

PN 2273139-1

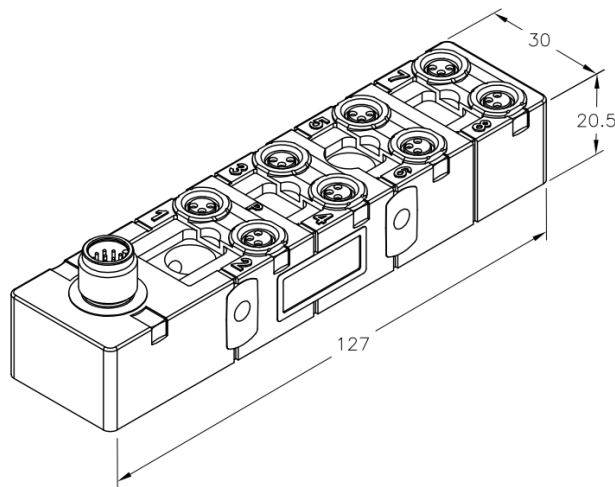

PN 2273146-1

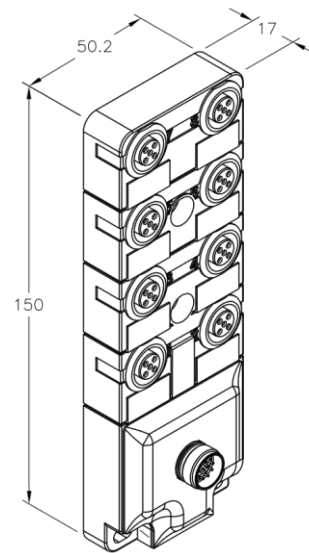

PN 2273161-1



7. DATA LINK

Note that the digital output (GPO) does not have a reverse polarity protection. Extra care should be taken to assure that the output is connected correctly.

8. UNSPECIFIED SITUATIONS

There are a number of unspecified situations in which the operation is not guaranteed.

8.1 Mating distance bigger than 7mm

In case the axial distance between TX and RX is just over 7 mm (at full load) or over 8 mm (at low load) the Voltage Output of the RX might be unstable: the pair continuously switches on and off.

8.2 Input Voltage below $24V_{DC} - 10\%$

Although an Under-Voltage Lockout is specified, the behavior at voltage levels between the Under-Voltage Lockout level and the minimum input voltage (21.6V) is not defined. Repeated ON and OFF switching of the Output Voltage at the RX side might occur, depending upon the load and the actual Input Voltage.

8.3 Metal clearance less than 30mm

Although Foreign Object Detection is present, no metal objects should be placed in the region between TX and RX. Those metal objects might get hot depending upon their geometry.

8.4 Inter coupler distance less than 60mm

In case two coupler pairs are located in close proximity (distance between central axes of both pairs less than 60mm) both Power and Data Transfer of any of the two pairs, might be affected by the proximity of the other coupler pair.

8.5 Ambient temperature higher than 60°C

Although the power transmitter side has an Over Temperature Protection, putting the RX in an environment higher than 60°C might result in malfunctioning.

8.6 UV environment

The product should not be used in environments with high UV radiation or with chemical compounds.

9. SAFETY NOTES AND DISCLAIMERS

9.1 Personnel requirements

Installation and startup are permitted only by trained technicians.

9.2 Non-intended use

Guarantee and warranty claims against the manufacturer are rendered non-redeemable by unauthorized operations, tampering and non-intended use.

9.3 Electric and magnetic field emission

The device (coupler pair) can be used according to its intended application (keeping minimum separation distance of 20cm from human body) without any access restrictions.

9.4 Hot surfaces



The active surface heats up even under normal operation conditions.
Contact of metal objects on the active surface should be avoided (Fire Hazard).

9.5 Foreign metal objects



Although Foreign Object Detection is implemented, small metal devices located between the transmitter and receiver can get very hot, even with the risk of fire in case of combustible material near the metal.
Whether the metal devices will get hot depends upon their size and geometry.

9.6 Power supply and Class of Equipment

The power supply generating the necessary 24V_{DC} for the TX should have either double isolated or reinforced isolation (safety extra low voltage output: double reinforced isolation from primary mains).

The product shall be connected to a power supply with Class II protected outputs.

The product has Class of Equipment III.

9.7 Cable protection

In static applications, the cable bending radius at coupler shall be at minimum 5 times the cable diameter.

9.8 Moving and rotating applications



Especially in moving and/or rotating applications the cables should be protected and mounted into clips / straps. In dynamic applications, the cable bending radius shall be at minimum 10 times the cable diameter. Furthermore, especially in rotating applications, special attention should be paid to the balance of the total setup.

9.9 Human protection



Especially in moving / rotation applications the human body should be protected against any harm (crushing, cutting etc.)

9.10 Safety and environment



This product shall not be used in a safety critical application.
This product shall not be used in space applications at low pressure that could cause outgassing of the materials.

9.11 Frequency Bands and Maximum Output Power

The Radio Equipment operates within the following Frequency Band with the following Maximum Output Power

Frequency Band [MHz]	Maximum Transmitted Radio-Frequency Power [mW]
2400 – 2483.5	4.27

The product complies with Article 10.8 of Radio Equipment Directive 2014/53/EU.

10. OTHERS

The product described herein has not been fully tested to ensure conformance to the requirements outlined above. TE makes no representation or warranty, expressed or implied, that the product or design will comply with these requirements. Further, TE may change these requirements based on the results of additional testing and evaluation. Contact TE Engineering for further details.



NOTES AND STATEMENTS **FCC ID: 2ADK7-ARISO**
IC: 12496A-ARISOTX and 12496A-ARISORX

Intended use: Coupler to transfer 12W power and data (digital GPIO link), integrated in a control system.

This device complies with Industry Canada licence-exempt RSS standard(s) and part 15 of the FCC Rules. Operation is subject to the following two conditions: (1) this device may not cause harmful interference, and (2) this device must accept any interference received, including interference that may cause undesired operation.

Changes or modifications not expressly approved by the party responsible for compliance could void the user's authority to operate the equipment.

This equipment has been tested and found to comply with the limits for a Class A digital device, pursuant to part 15 of the FCC Rules. These limits are designed to provide reasonable protection against harmful interference when the equipment is operated in a commercial environment. This equipment generates, uses, and can radiate radio frequency energy and, if not installed and used in accordance with the instruction manual, may cause harmful interference to radio communications. Operation of this equipment in a residential area is likely to cause harmful interference in which case the user will be required to correct the interference at his own expense.

The interference potential of the device is low as it is a low frequency device with a near field antenna, designed to provide reasonable protection against harmful interference when the equipment is operated in a commercial environment and accordingly tested.

If this equipment does cause harmful interference, which can be determined by turning the equipment off and on by disconnecting the couplers from the power and signal source, the user is encouraged to try to correct the interference by one or more of the following measures:

- 1. Increase the separation between this equipment and the disturbed one*
- 2. Consult the dealer or an experienced technician for help*

No maintenance of the device is needed, once installed and used in accordance with the instruction manual.

Notes et déclarations:

Le présent appareil est conforme aux CNR d'Industrie Canada applicables aux appareils radio exempts de licence. L'exploitation est autorisée aux deux conditions suivantes: (1) l'appareil ne doit pas produire de brouillage, et (2) l'appareil doit accepter tout brouillage radioélectrique subi, même si le brouillage est susceptible d'en compromettre le fonctionnement.