

NOTE: All numerical values are in metric units [with U.S. customary units in brackets]. Dimensions are in millimeters [and inches]. Unless otherwise specified, dimensions have a tolerance of ± 0.13 [$\pm .005$] and angles have a tolerance of $\pm 2^\circ$. Figures and illustrations are for identification only and are not drawn to scale.

1. INTRODUCTION

This specification covers the requirements for application of essential FASTON and Positive lock. This F wire barrel crimp feature provides reliable electrical and mechanical performance. Also, most receptacles are made in two standard tab thicknesses: 0.51 and 0.81 mm [.020 and .032 in].

When corresponding with TE Connectivity Personnel, use the terminology provided in this specification to facilitate your inquiries for information.



250 FASTON



187 Positive lock

2. REFERENCE MATERIAL

2.1. Drawings

Customer drawings for product part numbers are available from www.te.com. Information contained in the customer drawing takes priority.

2.2. Specifications

These terminals are designed to perform to the test described by 108-106542 and 108-106546

2.3. Instructional Material

The following available Instruction Sheets (408-series) are customer documents that provide application tooling information.

408-10390 Instruction Sheet for Ocean End-Feed Applicators

3. REQUIREMENTS

3.1. Storage

A. Chemical Exposure

Do not store product near any chemical listed below as they may cause stress corrosion cracking in the material.

Alkalies	Ammonia	Citrates	Phosphates	Citrates	Sulfur Compounds
Amines	Carbonates	Nitrites	Sulfur Nitrites		Tartrates

**NOTE**

Where above environmental conditions exist, use phosphor-bronze receptacles instead of brass.

3.2. Wire Selection and Preparation

A. Selection

There are receptacle designs to accommodate a wire size range of 22 to 16 AWG and an insulation diameter range of 1.60 through 3.0 mm [.062 through .118 in.]. Selection is based on the application requirements (i.e., electric or signal carrying parameters).

B. Preparation

Strip the wire insulation according to the dimension provided in Figure 1.

RECEPTACLE SERIES	STRIP LENGTHS (± 0.5 [.020])	
	WITH INSULATION SUPPORT	
250	4.00 [.157]	
187	4.00 [.157]	---

Figure 1

**CAUTION**

Do NOT nick, scrape, or cut the wire conductor during the stripping operation.

3.3. Crimped Requirements

Locate the receptacle to be crimped in the appropriate tooling and perform the crimping operation according to the instructions packaged with that tooling. Check the appearance and crimping dimensions of the crimped terminal as follows.

A. Crimp Dimensions

The applied crimp dimension (within the functional range of the product) is dependent on the termination tooling being used.

Terminal P/N	Wire crimping Data			Insulation crimp
	Wire Size [AWG]	Crimp Width (Ref)(mm)	Crimp Height(mm)	Crimp width(mm)
2366406-X & 2366410-X	18	1.78	1.17+/-0.05	3.00
	20		1.02+/-0.05	
	22		0.94+/-0.05	
2366407-X & 2366413-X	16	2.03	1.32+/-0.05	3.30
	18		1.17+/-0.05	

**NOTE**

The applied crimp dimension (within the functional range of the product) is dependent on the termination tooling being used. For all other products, refer to the documentation (applicator logs and instruction sheets) supplied with the termination tooling for the applied crimp height.

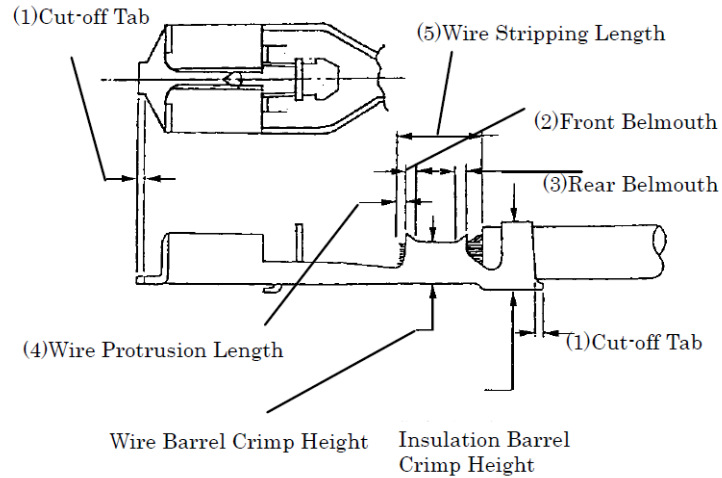
B. Crimp Requirement

No.	Item	Specified Limit
1	Cut-off tab length	0.5mm max.
2	Front bell mouth	0.4mm max.
3	Back bell mouth	0.2-0.6mm
4	Wire End Protrusion Length	Tip of wire shall protrude from wire barrel crimp, but shall not exceed 1.0mm
5	Wire stripping length	4.0+/-0.50mm
6	Bend-up	5° max.
7	Bend-down	5° max.
8	Twisting	5° max.
9	Rolling	10° max.

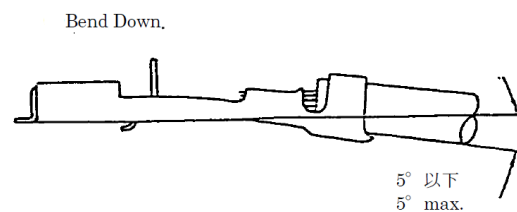
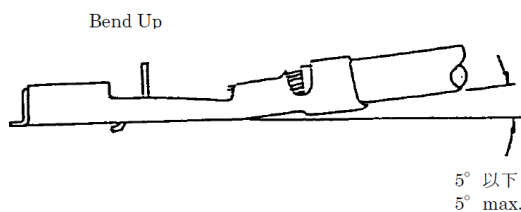

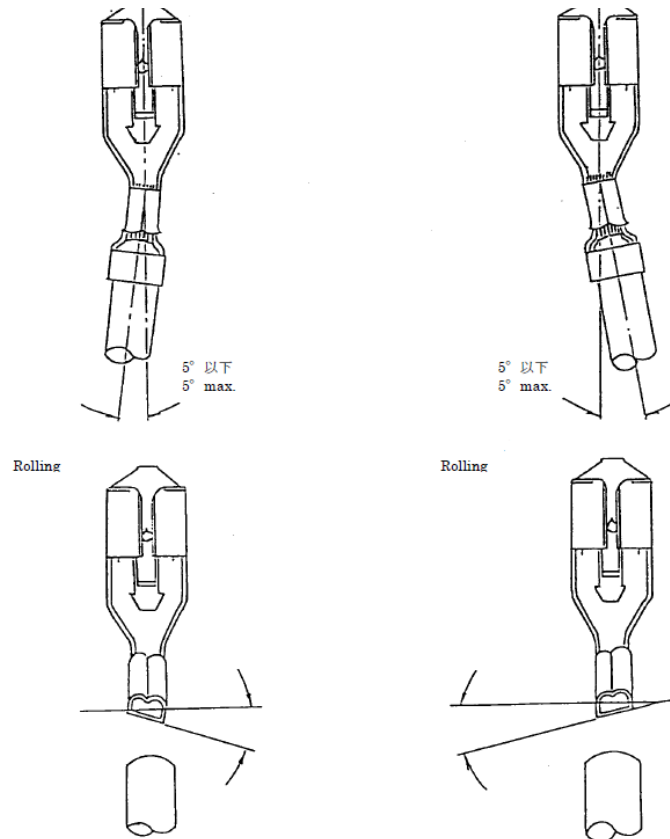

3.4. Crimp Pull-Out Test

Crimped receptacles shall not separate from wires when subjected to forces specified in Figure 2. **These performance verifications are a crimp integrity set-up REQUIREMENT.**



NOTE

Adjust tensile testing machine for head travel of 24.5 mm [1.00 in] per minute. Directly and gradually apply force for 1 minute. (Hold the receptacle so that the force is applied straight-parallel to the crimp.)

WIRE SIZE (AWG)	MINIMUM FORCE	
	NEWTONS (N)	POUNDS (LBS)
22	36	8
20	58	13
18	89	20
16	133	30

Figure 2

3.5. Mating Tab Dimensions

Features and dimensional requirements for tab terminals to be mated FASTON and positive lock are shown in Figure 3.

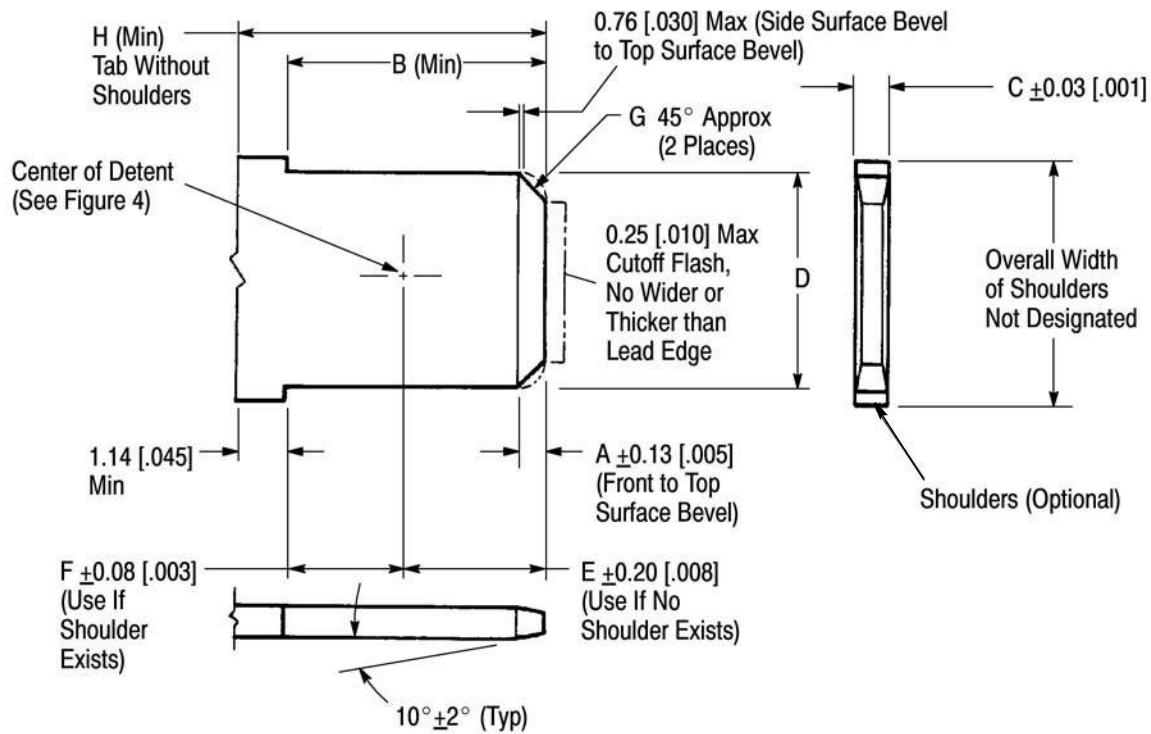

Figure 3 (continued)

TAB SIZE (Nominal)	DIMENSION							
	A	B	C	D	E	F	G	H
6.35 x 0.81 [.250 x .032] w/Hole	0.89 [.035]	7.80 [.307]	0.81 [.032]	6.35 [.250]	4.52 [.178]	3.40 [.134]	1.27 [.050]	8.94 [.352]
4.75 x 0.51 [.187 x .020] w/Hole	0.76 [.030]	6.22 [.245]	0.51 [.020]	4.75 [.187]	3.17 [.125]	3.17 [.125]	1.14 [.045]	7.37 [.290]

NOTES: (1) Bevel may be a straight line or a radius within $G \pm 0.51 \text{ mm} [\pm 0.020 \text{ in.}]$. (2) Tab shall be flat (.001 inch/inch); and free from burrs greater than 10% of tab thickness, or raised plateaus, except as noted in Paragraph 3.8. (3) Measurements shall not include plating, burrs, or flatness tolerance.

Figure 3

3.6. Tab Retention and Detent Configurations

A tab configuration having no locking feature may be used for applications where low mating retention forces are desirable. Where higher forces are sought, a tab with a detent meeting specific requirements should be used. Hole detents provide the greatest retention forces, while dimples provide acceptable medium-range forces.

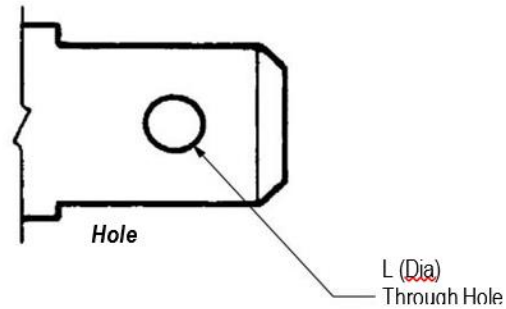

TAB WIDTH (Nominal)	DIMENSION
	L
6.35 [.250]	1.78 +0.25/-0.13 [.070 +0.10/-0.005]
4.75 [.187]	1.40 +0.13 [.055 +.005]

Figure 4

3.7. Repair

These receptacles are not repairable once termination has been made. Any defective receptacles should be removed and replaced with a new one.

4. TOOLING

Applicators and automatic machines are recommended for all applications. Applicators contain the tooling for feeding and crimping strip-form terminals. Automatic machines provide the power to operate the applicator. See figure 5 for representative images.

Tooling information for product part numbers is available from www.te.com or by calling the Product Information Center at the number at the bottom of page 1.



CAUTION

Tool life may be significantly reduced when crimping comparable steel/nickel plated steel terminals.

4.1. Applicators

Applicators for product part numbers are available from the [Applicator Search Portal](#) on www.te.com or by calling the Product Information Center at the bottom of page 1

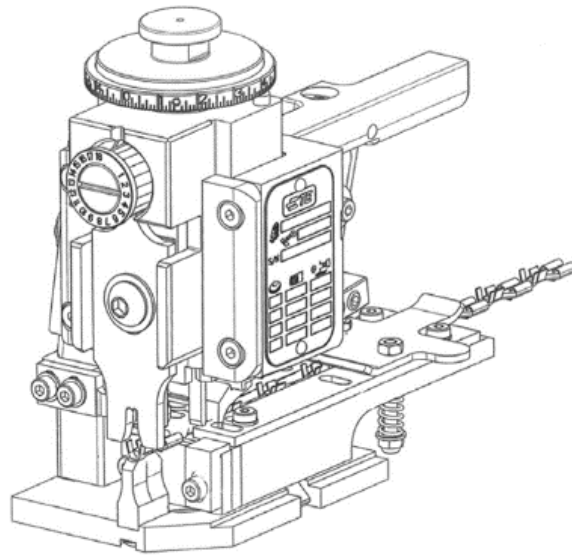

Mouser Electronics

Authorized Distributor

Click to View Pricing, Inventory, Delivery & Lifecycle Information:

[TE Connectivity:](#)

[2366406-2](#)