









- Relays of general application • For plug-in sockets: 35 mm rail mount acc. to PN-EN 60715; on panel mounting; solder terminals • Contacts AgNi • Coils AC and DC • WT (mechanical indicator + lockable front test button) - standard features of relays in cover, for plug-in sockets. Relays may be provided with the test buttons (no latching) and plugs
- Have obtained LR Type Approval Certificate (Lloyd's Register) Recognitions, certifications, directives: RoHS, AUCOTEAM GmbH Berlin - railroad standard,      

Contact data

Number and type of contacts		2 CO, 3 CO
Contact material		AgNi, AgNi/Au 0,2 µm, AgNi/Au 5 µm
Rated / max. switching voltage	AC	250 V / 440 V
Min. switching voltage		10 V AgNi, 10 V AgNi/Au 0,2 µm, 5 V AgNi/Au 5 µm
Rated load (capacity)	AC 1	10 A / 250 V AC 10 A / 277 V AC UL 508
	AC15	3 A / 120 V 1,5 A / 240 V (B300)
	AC3	370 W (single-phase motor, 1/2 HP / 240 V AC UL 508)
	DC1	10 A / 24 V DC (see Fig. 3)
	DC13	0,22 A / 120 V 0,1 A / 250 V (R300)
Min. switching current		5 mA
Max. inrush current		20 A
Rated current		10 A
Max. breaking capacity	AC1	2 500 VA
Min. breaking capacity		0,3 W AgNi, 0,3 W AgNi/Au 0,2 µm, 0,05 W AgNi/Au 5 µm
Contact resistance		≤ 100 m Ω
Max. operating frequency		
• at rated load	AC 1	1 200 cycles/hour
• no load		12 000 cycles/hour

Coil data

Rated voltage	50/60 Hz AC	6 ... 240 V
	DC	6 ... 220 V
Must release voltage		AC: ≥ 0,15 U _n DC: ≥ 0,1 U _n
Operating range of supply voltage		see Tables 1, 2
Rated power consumption		AC: 2,8 VA 50 Hz 2,5 VA 60 Hz DC: 1,5 W

Insulation according to PN-EN 60664-1

Insulation rated voltage		250 V AC
Rated surge voltage		2 500 V 1,2 / 50 µs
Overvoltage category		III
Insulation pollution degree		3
Dielectric strength		
• between coil and contacts		2 500 V AC type of insulation: basic
• contact clearance		1 500 V AC type of clearance: micro-disconnection
• pole - pole		2 000 V AC type of insulation: basic
Contact - coil distance		
• clearance		≥ 3 mm
• creepage		≥ 4,2 mm

General data

Operating / release time (typical values)		AC: 12 ms / 10 ms DC: 18 ms / 7 ms
Electrical life		
• resistive AC1		> 2 x 10 ⁵ 10 A, 250 V AC
• cos φ		see Fig. 2
Mechanical life (cycles)		> 2 x 10 ⁷
Dimensions (L x W x H)		35 x 35 x 54,4 mm
Weight		83 g
Ambient temperature	• storage	-40...+85 °C
	• operating	AC: -40...+55 °C DC: -40...+70 °C
Cover protection category		IP 40 PN-EN 60529
Environmental protection		RTI PN-EN 116000-3
Shock resistance		10 g
Vibration resistance		5 g 10...150 Hz
Solder bath temperature		max. 270 °C
Soldering time		max. 5 s

The data in bold type pertain to the standard versions of the relays.

R15 - 2 CO, 3 CO industrial relays of small dimensions

Coil data - DC voltage version

Table 1

Coil code	Rated voltage V DC	Coil resistance at 20 °C Ω	Acceptable resistance	Coil operating range V DC	
				min. (at 20 °C)	max. (at 55 °C)
1006	6	28	± 10%	4,8	6,6
1012	12	110	± 10%	9,6	13,2
1024	24	430	± 10%	19,2	26,4
1048	48	1 750	± 10%	38,4	52,8
1060	60	2 700	± 10%	48,0	66,0
1110	110	9 200	± 10%	88,0	121,0
1120	120	11 000	± 10%	96,0	132,0
1220	220	37 000	± 10%	176,0	242,0

The data in bold type pertain to the standard versions of the relays.

Coil data - AC 50/60 Hz voltage version

Table 2

Coil code	Rated voltage V AC	Coil resistance at 20 °C Ω	Acceptable resistance	Coil operating range V AC	
				min. (at 20 °C)	max. (at 55 °C)
5006	6	4,3	± 15%	4,8	6,6
5012	12	18,5	± 15%	9,6	13,2
5024	24	75,0	± 15%	19,2	26,4
5048	48	305,0	± 15%	38,4	52,8
5060	60	475,0	± 15%	48,0	66,0
5115	115	1 840,0	± 15%	92,0	126,5
5120	120	1 910,0	± 15%	96,0	132,0
5220	220	6 980,0	± 15%	176,0	242,0
5230	230	7 080,0	± 15%	184,0	253,0
5240	240	7 760,0	± 15%	192,0	264,0

The data in bold type pertain to the standard versions of the relays.

Dimensions - plug-in version (WT), with lockable front test button type T

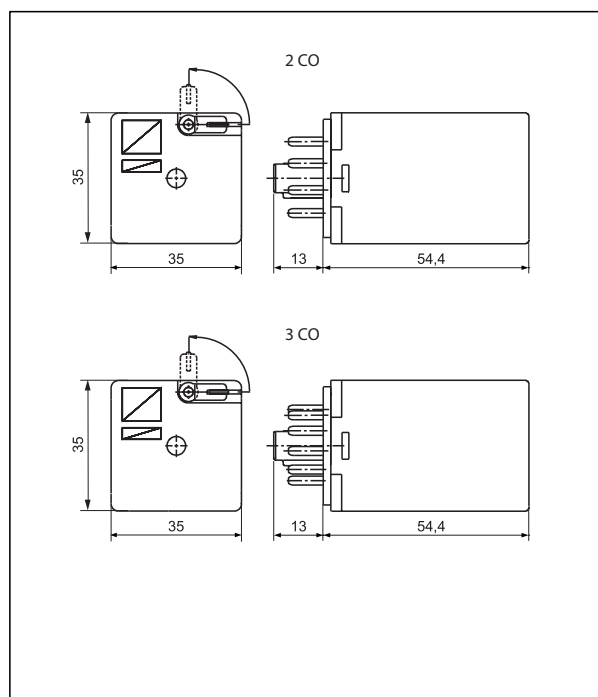

Dimensions - plug-in version, with test button (no latching) or with plug (no manual operation)

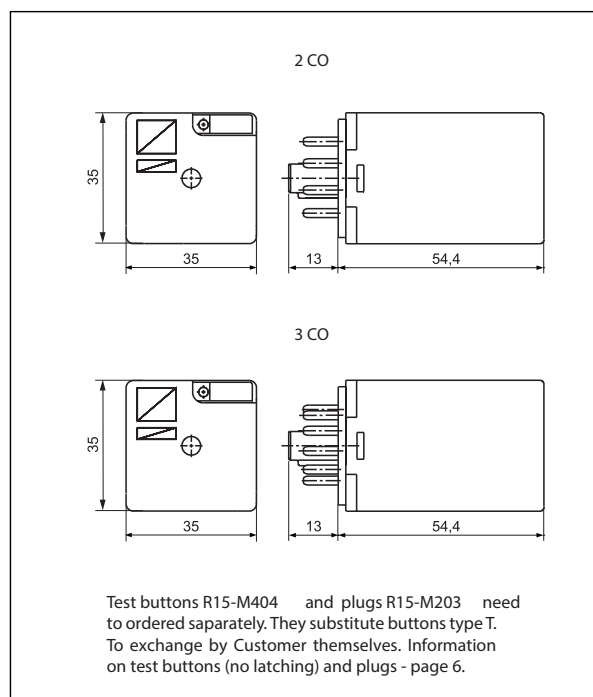

R15 - 2 CO, 3 CO industrial relays of small dimensions

Electrical life at AC resistive load.
 Switching frequency: 1 200 cycles/hour

Fig. 1

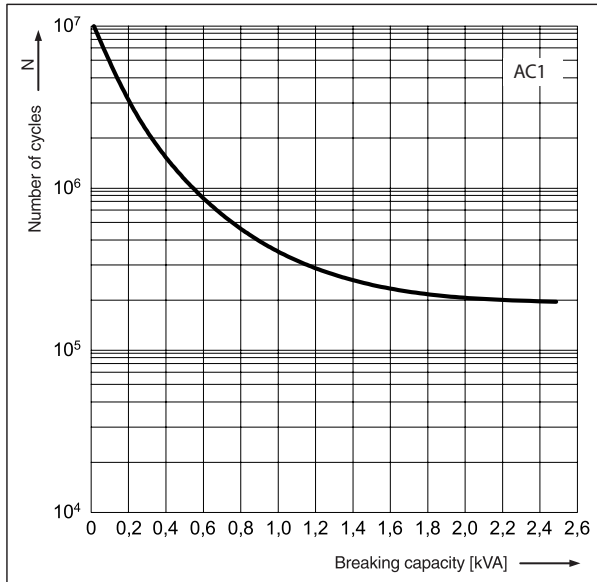

Electrical life reduction factor at AC inductive load

Fig. 2

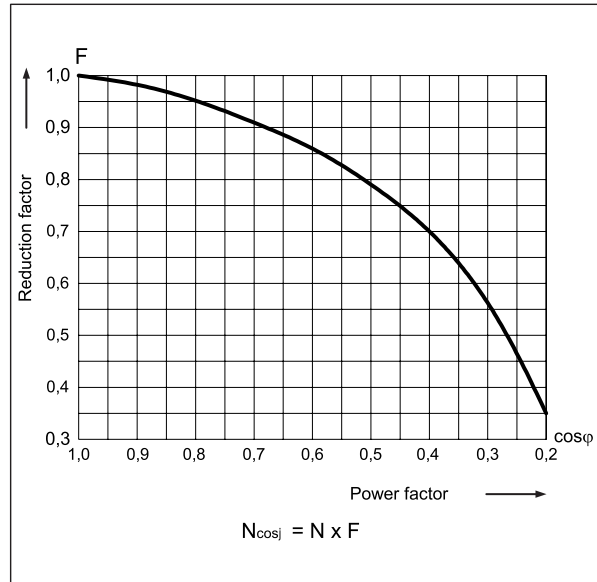

Max. DC breaking capacity
A - resistive load DC1
B - inductive load L/R = 40 ms

Fig. 3

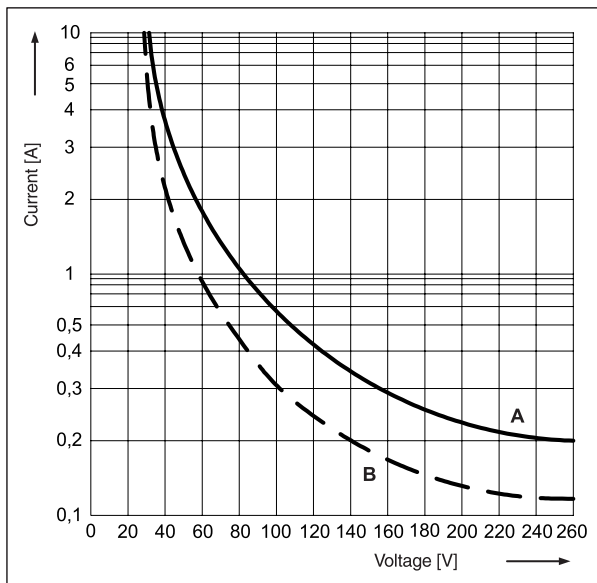

Connection diagrams (pin side view)

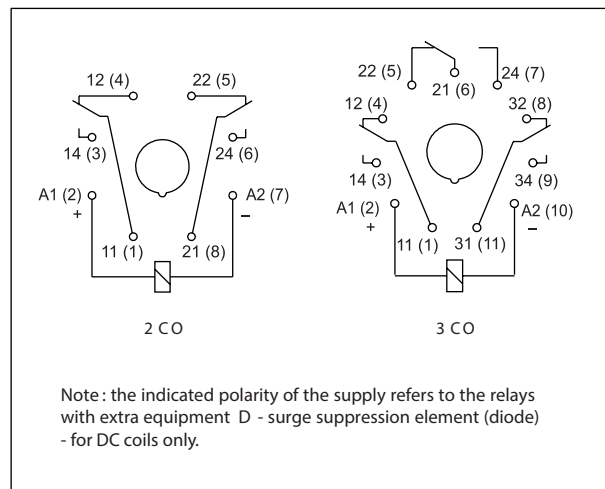

Mounting

Relays R15 - 2 CO are designed for: • screw terminals plug-in sockets PZ8 with clip PZ11 0031, 35 mm rail mount acc. to PN-EN 60715 or on panel mounting with two M3 screws • screw terminals plug-in sockets GZU8 with clip GZU 1052, 35 mm rail mount acc. to PN-EN 60715 • screw terminals plug-in sockets GZ8 with clip GZ 1050, on panel mounting with two M3 screws • screw terminals plug-in sockets GZS8, 35 mm rail mount acc. to PN-EN 60715 or on panel mounting with two M3 screws • screw terminals plug-in sockets GZP8 with clip GZP-0054, 35 mm rail mount acc. to PN-EN 60715 or on panel mounting with two M3 screws • solder terminals sockets GOP8 with clip R159 1051 and spring clamp R15 5922 • direct PCB mounting.

Relays R15 - 3 CO are designed for: • screw terminals plug-in sockets PS11 and PZ11 with clip PZ11 0031, 35 mm rail mount acc. to PN-EN 60715 or on panel mounting with two M3 screws • screw terminals plug-in sockets GZU11 with clip GZU 1052, 35 mm rail mount acc. to PN-EN 60715 • screw terminals plug-in sockets GZ11 with clip GZ 1050, on panel mounting with two M3 screws • screw terminals plug-in sockets GZS11, 35 mm rail mount acc. to PN-EN 60715 or on panel mounting with two M3 screws • screw terminals plug-in sockets GZP11 with clip GZP-0054, 35 mm rail mount acc. to PN-EN 60715 or on panel mounting with two M3 screws • solder terminals sockets GOP11 with clip R159 1051 and spring clamp R15 5922 • direct PCB mounting.

R15 - 2 CO, 3 CO industrial relays of small dimensions

Mounting

Relays R15 - 2 CO, 3 CO are offered in version : • standard WT (mechanical indicator + lockable front test button), for plug-in sockets. In standard version of relays (WT) is possibility self-exchange of button type T for test button R15-M404 (no latching) or plug R15-M203 (no manual operation). Test buttons (no latching) and plugs need to ordered separately .

Ordering codes

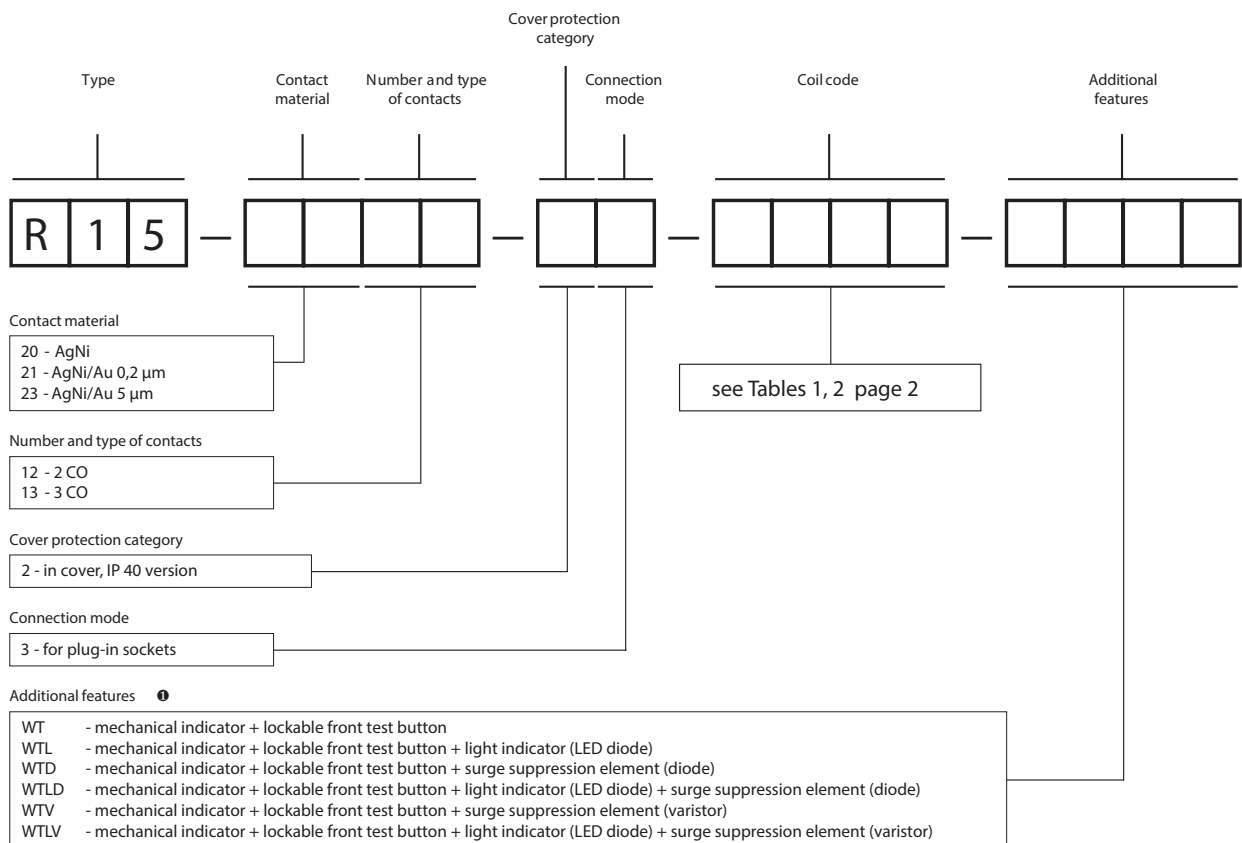

① WT - standard features of relays for plug-in sockets. WTD, WTLT - only for DC coils, WTV, WTLV - only for AC coils

Test buttons (no latching) and plugs need to ordered separately. They substitute buttons type T. To exchange by Customer themselves. Information on test buttons (no latching) and plugs - page 6.

- Button R15-M404-A - orange colour (AC coils)
- Button R15-M404-D - green colour (DC coils)
- Plug R15-M203-A - orange colour (AC coils)
- Plug R15-M203-D - green colour (DC coils)

Note:

For relays with additional features D - surge suppression element (diode) (versions WTD and WTLT) - fixed supply polarity compulsory for the DC load of coils: +A1(2) / -A2(7) for R15 - 2 CO and +A1(2) / -A2(10) for R15 - 3 CO. The polarity is indicated on the relay cover. For other versions of the relays with DC coils any polarity is possible.

Examples of ordering codes:

- R15-2012-23-1024-WT relay R15 , for plug-in sockets, two changeover contacts, contact material AgNi, coil voltage 24 V DC, with mechanical indicator and lockable front test button, in cover IP 40
- R15-2013-23-5230-WTL relay R15 , for plug-in sockets, three changeover contacts, contact material AgNi, coil voltage 230 V AC 50/60 Hz, with mechanical indicator and lockable front test button and light indicator (LED diode), in cover IP 40

Additional features for industrial relays

WT - mechanical indicator + lockable front test button

(basic features of standard industrial relays for plug-in sockets: R2, R3, R4, R15 - 2 CO, 3 CO).

Detailed information for individual relays: see "Ordering codes - Additional features".

Type ⓘ	Description	For industrial relays
W	mechanical indicator	R2, R3, R4 R15 - 2 CO, 3 CO
T	lockable front test button, orange colour - AC coils, green colour - DC coils	R2, R3, R4 R15 - 2 CO, 3 CO
L	light indicator (LED diode), located inside the relay	R2, R3, R4, RY2 R15 - 2 CO, 3 CO, 4 CO RUC, RUC-M
D	surge suppression element (diode) - only for DC coils	R2, R3, R4, RY2 R15 - 2 CO, 3 CO, 4 CO
V	surge suppression element (varistor) - only for AC coils	R15 - 2 CO, 3 CO
K	test button without block function	R15 - 4 CO RUC

ⓘ Available combinations:

- WT, WTL, WTD, WTL D - in relays R2, R3, R4 for plug-in sockets
- L, D, LD - in relays RY2 for plug-in sockets
- WT, WTL, WTD, WTL D, WTV, WTL V - in relays R15 - 2 CO, 3 CO for plug-in sockets
- K, L, D, KL, KD, LD, KLD - in relays R15 - 4 CO for plug-in sockets
- K, L, KL - in relays RUC
- L - in relays RUC-M

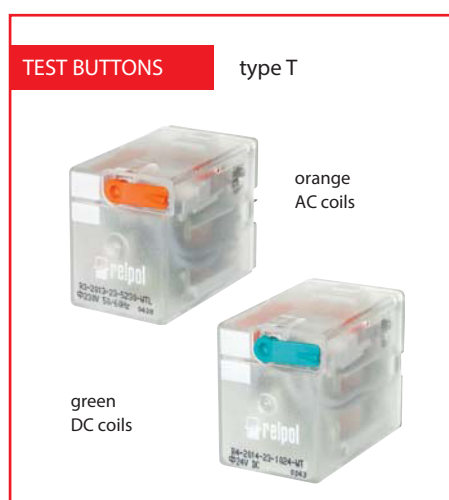

Test buttons (no latching) and plugs

Test buttons are recommended for R2...WT, R3...WT, R4...WT, R15...WT - 2 CO, 3 CO relays - for applications that do not allow permanent contact latching. By manual operation (pressing the button) relay contacts can get switched for as long time as long the button is pressed. Contacts return to initial position as soon as pressure is released from the button. Those operations can be done while the coil is deenergized.

Button R4P-0001 or R15-M404 can be easily inserted by the Customer after removal of button type T (see Fig. 2). Button type T can be removed with screwdriver as shown on Fig. 1.

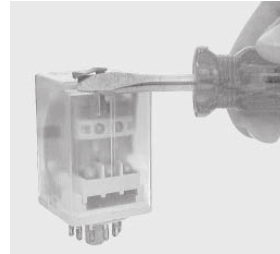

Fig. 1

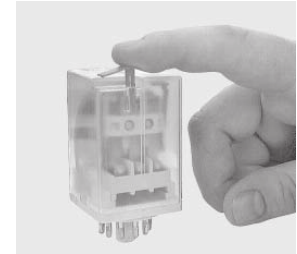
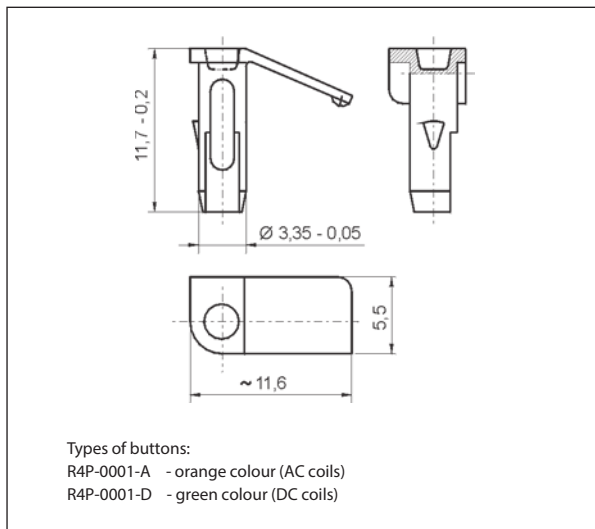
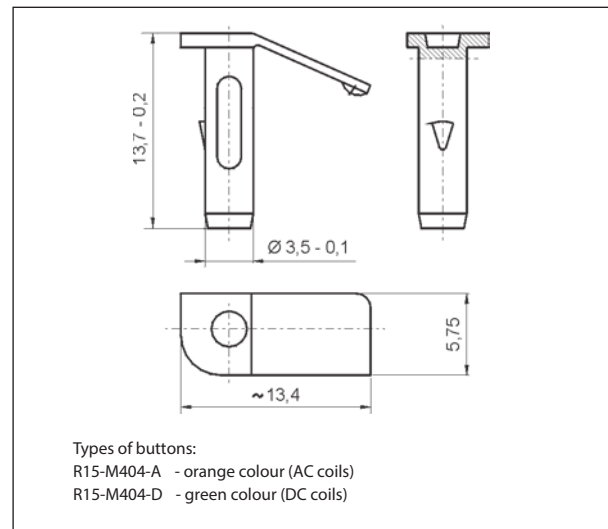

Fig. 2

Dimensions - test button R4P-0001
 for relays R2...WT, R3...WT, R4...WT



Dimensions - test button R15-M404
 for relays R15...WT - 2 CO, 3 CO



Plugs R4W-0003 or R15-M203 can substitute button type T if manual operation (latching and testing) is not allowed. Changing button type T for plug can be done by Customer themselves in the same way as changing button type T for button (no latching).

Dimensions - plug R4W-0003
 for relays R2...WT, R3...WT, R4...WT

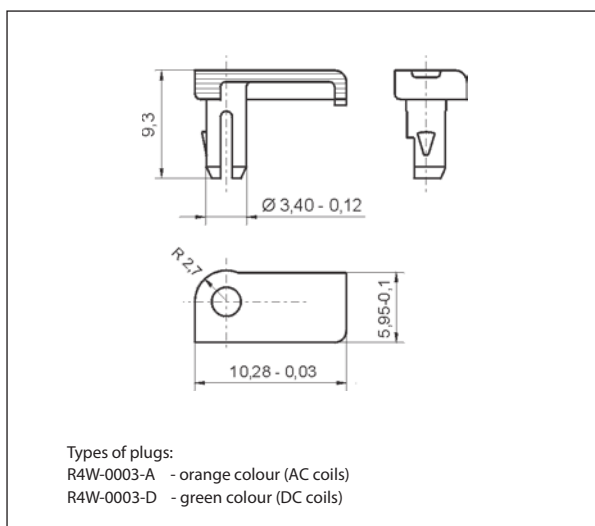

Dimensions - plug R15-M203
 for relays R15...WT - 2 CO, 3 CO

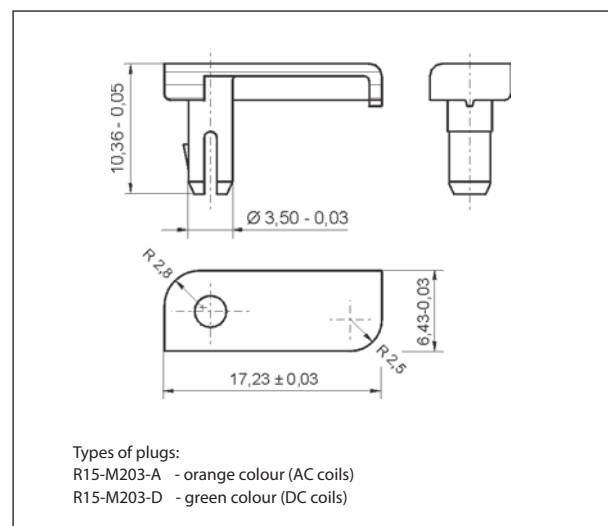

Plug-in sockets and accessories

PZ8 Ⓢ

For R15 - 2 CO

Screw terminals
 Max. tightening moment
 for the terminal: 0,7 Nm
 35 mm rail mount
 acc. to PN-EN 60715
 or on panel mounting
 68,2 x 38 x 24,2 mm
 Two poles
 10 A, 250 VAC



Connection diagram

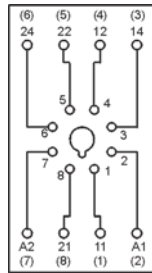

PZ11 0031

Dimensions

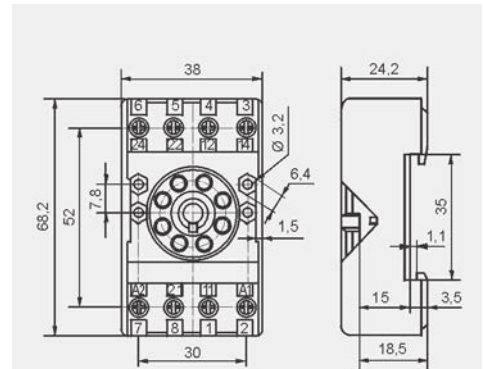

Accessories

GZU8

For R15 - 2 CO

Screw terminals
 Max. tightening moment
 for the terminal: 0,7 Nm
 35 mm rail mount
 acc. to PN-EN 60715
 82 x 35,5 x 25,7 mm
 Two poles
 10 A, 300 VAC



Connection diagram

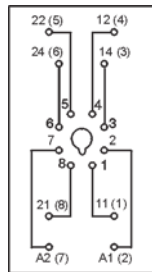

GZU 1052

Adaptor

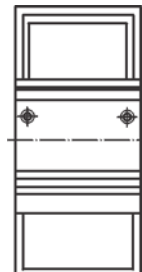

Dimensions

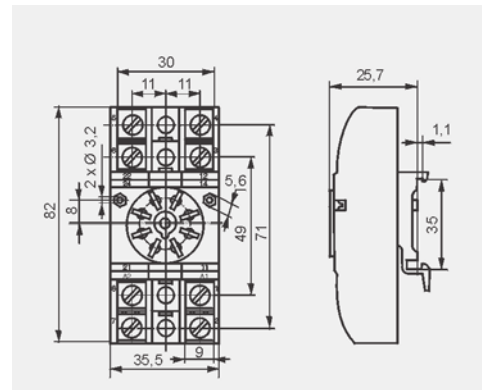

Accessories

GZ8

For R15 - 2 CO

Screw terminals
 Max. tightening moment
 for the terminal: 0,7 Nm
 On panel mounting
 82,8 x 35,5 x 22,5 mm
 Two poles
 10 A, 300 VAC



Connection diagram

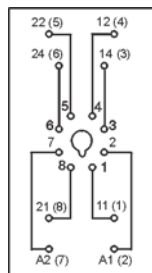

GZ 1050

Mounting dimensions

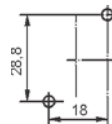

Dimensions

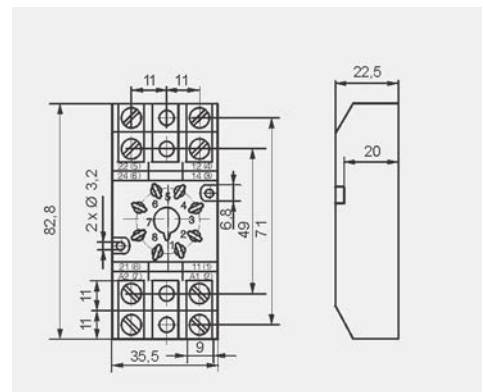

Ⓢ Have obtained LR Type Approval Certificate (Lloyd's Register).

Plug-in sockets and accessories

GZS8

For R15 - 2 CO

Screw terminals
 Max. tightening moment
 for the terminal: 1,0 Nm
 35 mm rail mount
 acc. to PN-EN 60715
 or on panel mounting
 51,3 x 40,8 x 21 mm
 Two poles
 10 A, 300 V AC



Connection diagram

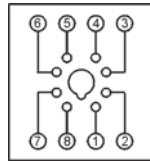

Dimensions

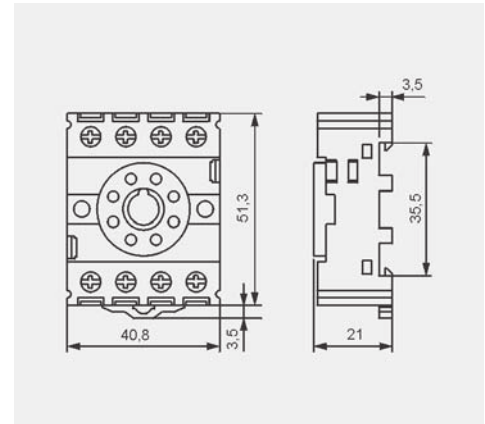

GZP8

For R15 - 2 CO

Screw terminals
 Max. tightening moment
 for the terminal: 0,5 Nm
 35 mm rail mount
 acc. to PN-EN 60715
 or on panel mounting
 73 x 38,2 x 27,2 mm
 Two poles
 12 A, 300 V AC



Connection diagram

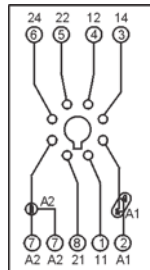

Time module T (COM3)



GZP-0054



GZP-0035

Dimensions

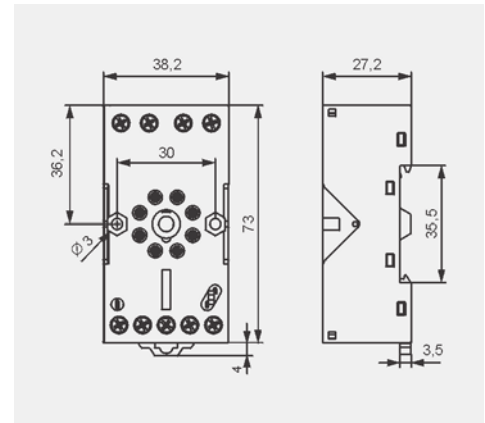

Accessories

GOP8

For R15 - 2 CO

Solder terminals
 47,2 x 32 x 22 mm
 Two poles
 10 A, 250 V AC



Dimensions

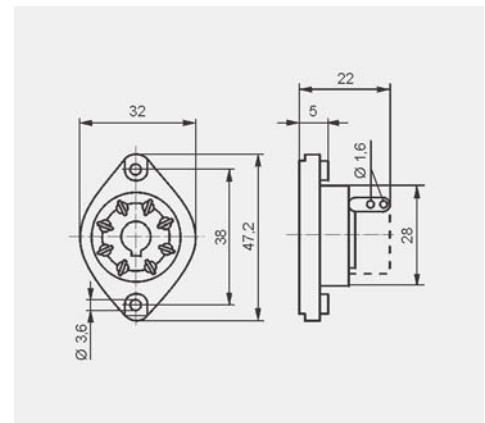

Accessories



R159 1051



R15 5922

Plug-in sockets and accessories

PS11 ⑥

For R15 - 3 CO

Screw terminals
Max. tightening moment
for the terminal: 0,7 Nm
35 mm rail mount
acc. to PN-EN 60715
or on panel mounting
68,2 x 38 x 24,2 mm
Three poles
10A, 250 VAC



Connection diagram

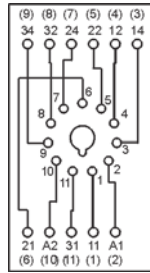

PZ11 0031

Dimensions

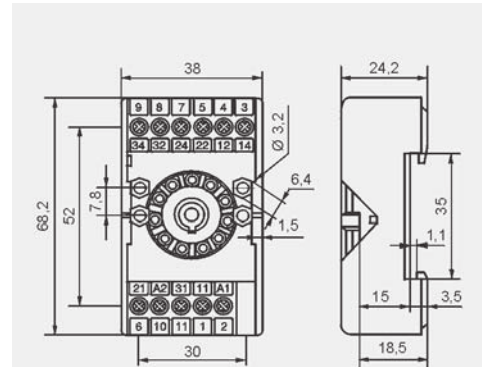

Accessories

PZ11 ⑥

For R15 - 3 CO

Screw terminals
Max. tightening moment
for the terminal: 0,7 Nm
35 mm rail mount
acc. to PN-EN 60715
or on panel mounting
68,2 x 38 x 24,2 mm
Three poles
10A, 250 VAC



Connection diagram

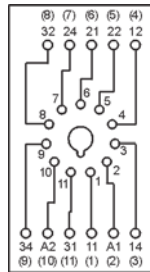

PZ11 0031

Dimensions

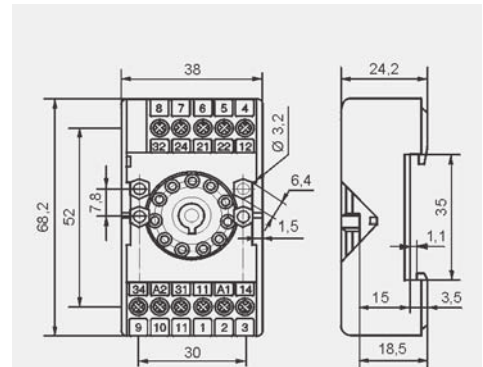

Accessories

GZU11

For R15 - 3 CO

Screw terminals
Max. tightening moment
for the terminal: 0,7 Nm
35 mm rail mount
acc. to PN-EN 60715
82 x 35,5 x 25,7 mm
Three poles
10A, 250 VAC



Connection diagram

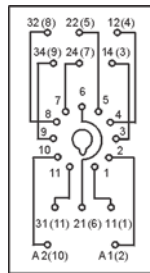

GZU 1052

Adaptor

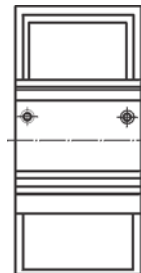

Dimensions

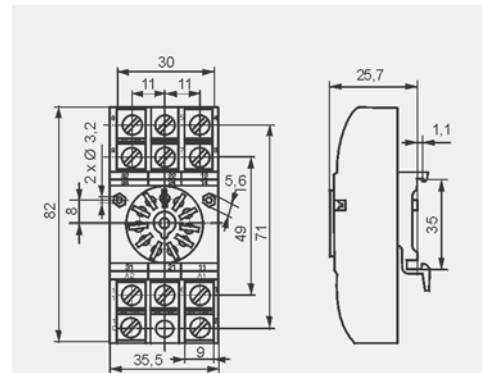

Accessories

GZ11

For R15 - 3 CO

Screw terminals
Max. tightening moment
for the terminal: 0,7 Nm
On panel mounting
82,8 x 35,5 x 22,5 mm
Three poles
10A, 250 VAC



Connection diagram

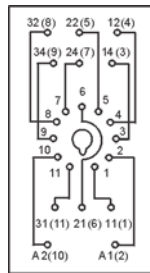

GZ1050

Mounting dimensions

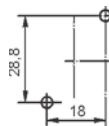

Dimensions

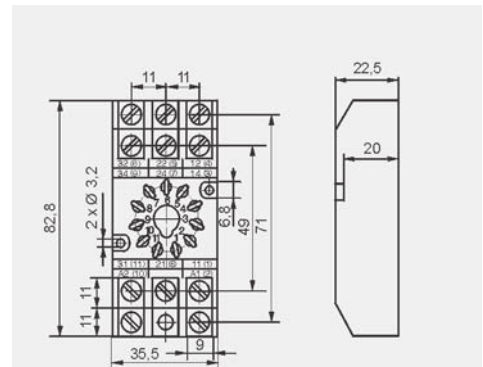

Accessories

Plug-in sockets and accessories

GZS11

For R15 - 3 CO

Screw terminals
 Max. tightening moment
 for the terminal: 1,0 Nm
 35 mm rail mount
 acc. to PN-EN 60715
 or on panel mounting
 51,3 x 43 x 30 mm
 Three poles
 10 A, 300 VAC



Connection diagram

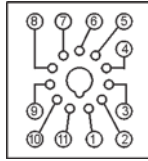

Dimensions

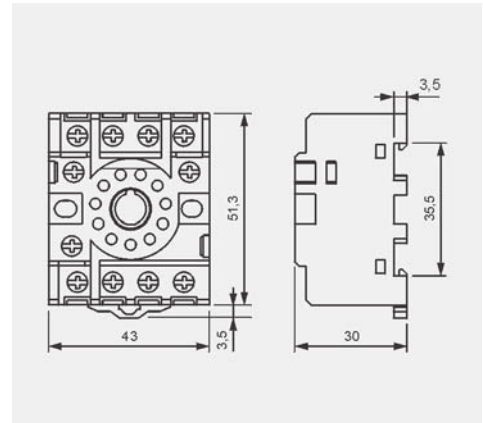

GZP11

For R15 - 3 CO

Screw terminals
 Max. tightening moment
 for the terminal: 0,5 Nm
 35 mm rail mount
 acc. to PN-EN 60715
 or on panel mounting
 73 x 38,2 x 27,2 mm
 Three poles
 12 A, 300 VAC



Connection diagram

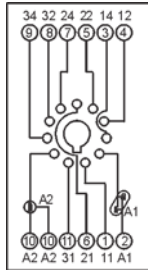

Time module T (COM3)



GZP-0054



GZP-0035

Accessories

Dimensions

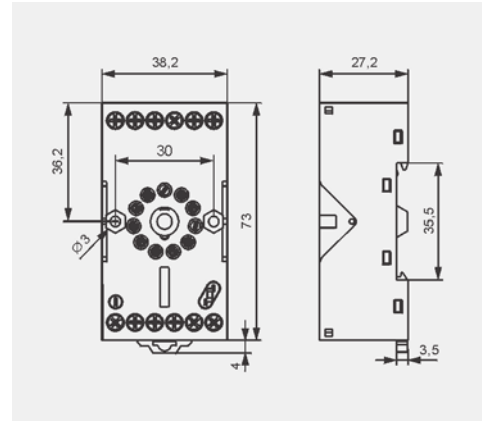

GOP11

For R15 - 3 CO

Solder terminals
 47,2 x 32 x 22 mm
 Three poles
 10 A, 250 VAC



Accessories



R159 1051



R15 5922

Dimensions

