

**Typical Specifications**

Items	Specifications		
	RDC40	RDC50	RDC90
Rated voltage	5V DC		
Operating life	100,000 cycles	1,000,000 cycles	10,000,000 cycles
Total resistance	10kΩ		3.3kΩ (RDC9010006) 10kΩ (RDC9010007)
Operating temperature range	-30°C to +80°C	-40°C to +120°C	

**Product Line**

Mounting method	Linearity guarantee range	Linearity	Hollow shaft variation	Operating life (cycles)	Minimum order unit (pcs.)		Model No.	Drawing No.
					Japan	Export		
Connector type	13 rotations	±1%	—	100,000	770	770	<b>RDC401D07A</b>	1
Horizontal type	320°	±2%	φ3.5 dia	1,000,000	1,500	3,000	<b>RDC501051A</b>	2
			φ3.5 dia with radius				<b>RDC501052A</b>	3
Vertical type			φ3.5 dia		1,600	1,600	<b>RDC502012A</b>	4
Reflow type			φ3.5 dia with radius		3,900	3,900	<b>RDC503051A</b>	5
			<b>RDC503052A</b>		6			
Reflow type (Low-profile)			φ4 dia		3,600	3,600	<b>RDC506018A</b>	7
Reflow type (Long-life)	60°	±3%	φ3.5 dia	10,000,000	1,960	1,960	<b>RDC9010006</b>	8
	244°						<b>RDC9010007</b>	

**Note**

Other varieties are also available. Please inquire.

**Packing Specifications**

Tray / Taping



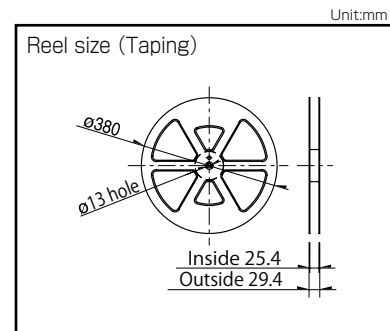



Series	Packing Specifications	Number of packages (pcs.)		Tape width (mm)	Export package measurements (mm)
		1 case / Japan	1 case / export packing		
<b>RDC40</b>	Tray	770	770	—	526×370×191
<b>RDC501</b>		1,500	3,000		
<b>RDC502</b>		1,600	1,600		
<b>RDC503</b>	Taping	3,900	3,900	24	415×407×135
<b>RDC506</b>		3,600	3,600		
<b>RDC90</b>	Tray	1,960	1,960	—	300×240×270

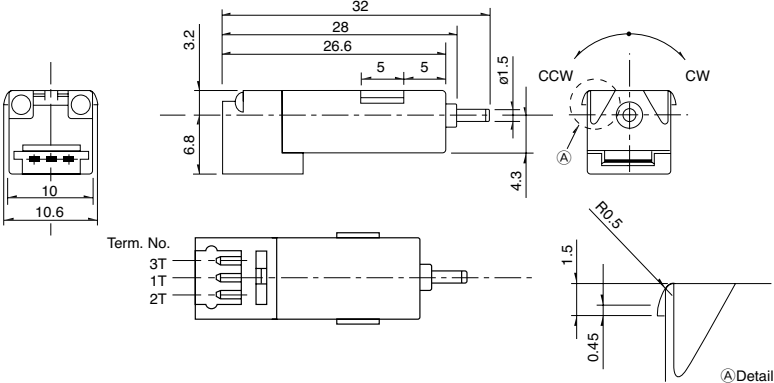

Refer to P.466 for product specifications.  
Refer to P.467 for soldering conditions.

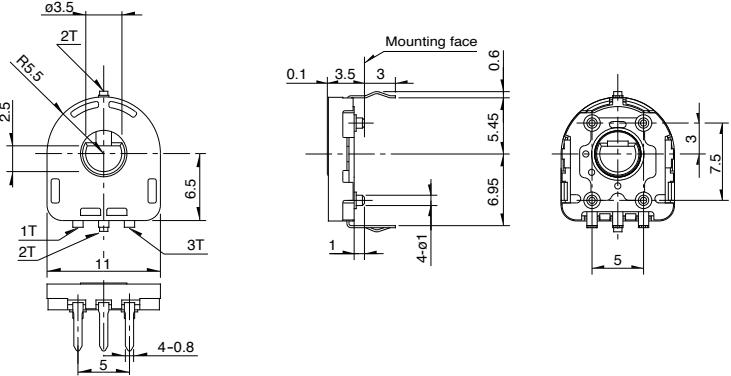
■ Dimensions

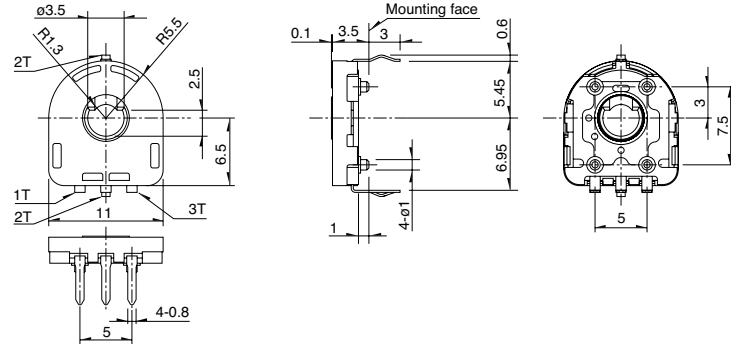
Unit:mm

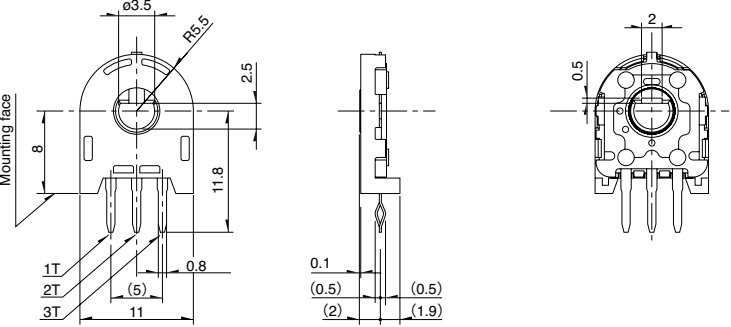
No.	Photo	Style
1	<p><b>RDC40 (Multiple turns type)</b></p> 	
2	<p><b>RDC501 (Horizontal type)</b></p> 	
3	<p><b>RDC501 (Horizontal type, ø3.5 dia with radius)</b></p> 	
4	<p><b>RDC502 (Vertical type)</b></p> 	







Resistive Position Sensors

Rotary Type

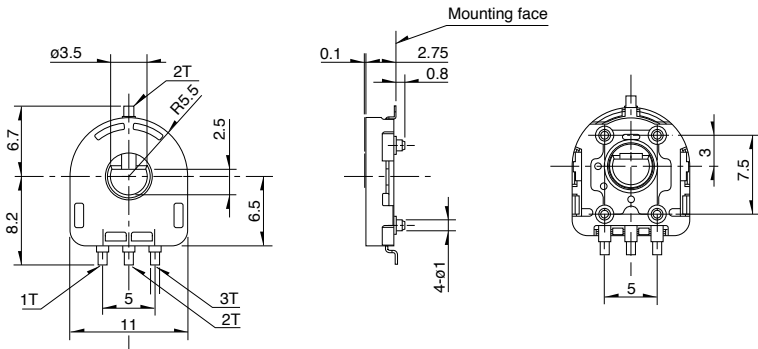
Linear Type

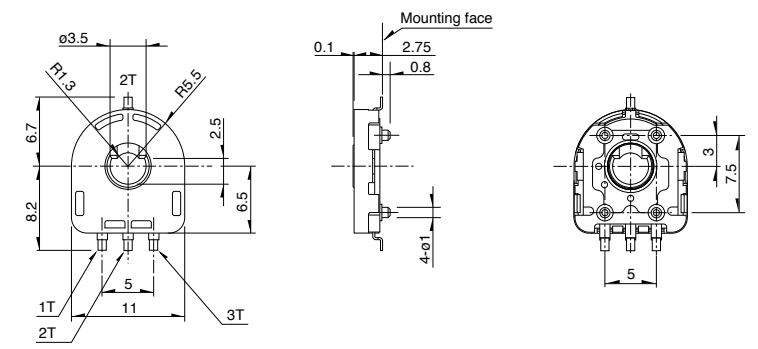
■ Dimensions

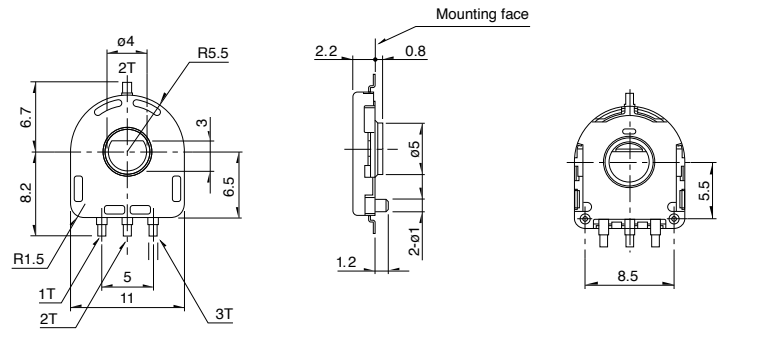
Unit:mm

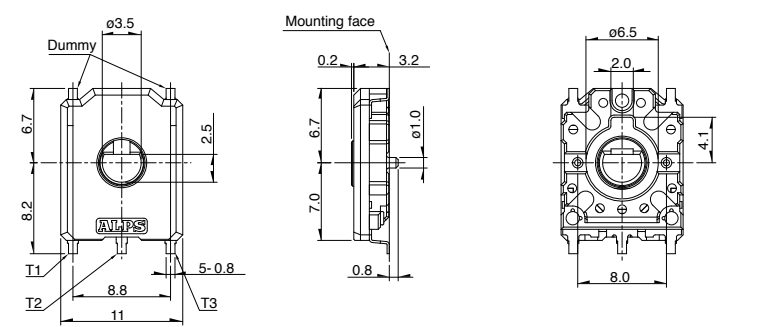
No.	Photo	Style
5	 <p><b>RDC503 (Reflow type)</b></p>	
6	 <p><b>RDC503 (Reflow type, ø3.5 dia with radius)</b></p>	
7	 <p><b>RDC506 (Reflow type, low-profile)</b></p>	
8	 <p><b>RDC90 (Reflow type, Long-life)</b></p>	

■ Circuit Diagram

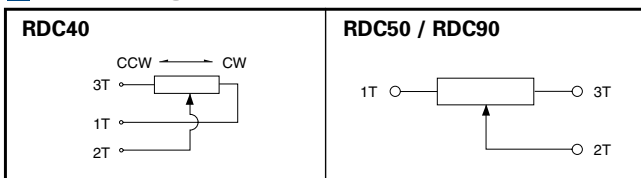

# Resistive Position Sensors

## List of Varieties

Type	Rotary Type			
Series	RDC40	RDC50	RDC90	RD6R1A
Photo				
Direction of lever	Horizontal	Vertical Horizontal	Vertical	
Effective electrical angle (°)	5,400 (15 rotations)	333.3	80,260	320
Linearity guarantee range (°)	4,680 (13 rotations)	320	60,244	310
Travel	—	—	—	—
Operating temperature range	−30°C to +80°C	−40°C to +120°C		−40°C to +85°C
Operating life	100,000 cycles	1,000,000 cycles	10,000,000 cycles	500,000 cycles
Available for automotive use	—	●	●	●
Life cycle (availability)				
Mechanical performance	Operating force	—	—	—
	Rotational torque	1.96mN·m max.	2mN·m max.	
Electrical performance	Total resistance tolerance	±30%		±20%
	Linearity (%)	±1	±2	±3
	Rated voltage (V DC)	5		
Environmental performance	Cold	−30°C 240h	−40°C 168h	
	Dry heat	80°C 240h	120°C 168h	85°C 168h
	Damp heat	60°C, 90 to 95%RH 240h	60°C, 90 to 95%RH 96h	
Terminal style	Connector	Insertion / Reflow	Reflow	Connector
Page	456			459

Resistive Position Sensors Measurement and Test Methods	466
Resistive Position Sensors Soldering Conditions	467
Resistive Position Sensors Cautions	467

### Note

- Indicates applicability to all products in the series.



## Reference for Manual Soldering

Series	Tip temperature	Soldering time
<b>RDC50, RDC90</b>	350±5°C	3 <sup>+</sup> <sub>0</sub> s
<b>RDC10, RD7</b>	350°C max.	3s max.

## Reference for Dip Soldering

Series	Preheating		Dip soldering		No. of solders
	Soldering surface temperature	Heating time	Soldering temperature	Soldering time	
<b>RDC501, RDC502</b>	100 to 150°C	1minute max.	260±5°C	10±1s	1 time
<b>RD7</b>	100°C max.	1minute max.	260°C max.	5s max.	1 time

## Example of Reflow Soldering Condition

- Cleaning sensors should not be attempted.
- Type of solder to be used Use cream solder that contains 10 to 15 %wt flux.
- Number of solder applications - apply solder only once
- Recommended reflow conditions

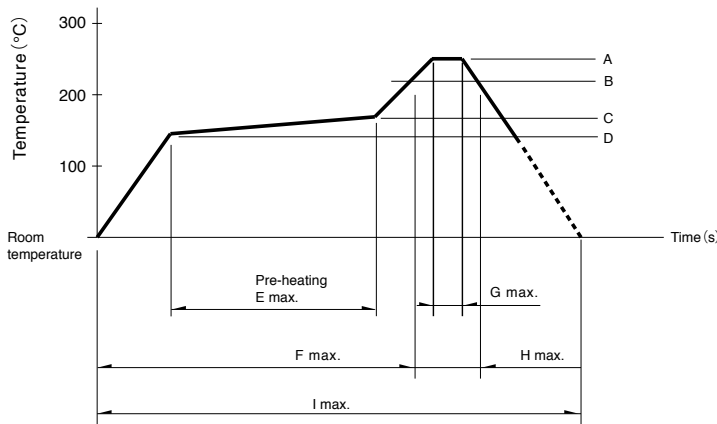

Series	A	B	C	D	E	F	G	H	I	No. of reflows
<b>RDC503 RDC506</b>	250°C	230°C	180°C	150°C	2min.	—	5s	40s	4min.	1 time
<b>RDC90</b>	255°C	230°C	—	—	—	2min.	10s	1min.	4min.	1 time

## Notes

- When using an infrared reflow oven, solder may not always be applied as intended. Be sure to use a hot air reflow oven or a type that uses infrared rays in combination with hot air.
- The temperatures given above are the maximum temperatures at the terminals of the sensor when employing a hot air reflow method. The temperature of the PC board and the surface temperature of the sensor may vary greatly depending on the PC board material, its size and thickness. Ensure that the surface temperature of the sensor does not rise to 250°C or greater.
- Conditions vary to some extent depending on the type of reflow bath used. Be sure to give due consideration to this prior to use.