

PART NUMBER	ITEM ① BODY	ITEM ② CONTACT	ITEM ③ INSULATOR	ITEM ④ BNC COUPLING NUT
CP-AD314	BRASS NICKEL PLATED	BERYLLIUM Ni/Au PLATED	DELTRIN	BRASS NICKEL PLATED

受控 CONTROLLED DOCUMENT				
编号 P/N	CP-AD314	版本 Rev	0B	日期 Rel'd Date
				Mar 24, 08

DRAWING NO. CP-AD314				
REVISIONS				
A RELEASE FOR QUOTATION				
11-02-05	L	Y	T	
	U			
ADD NOTE 3&4				
B				
11-08-06	W	W	T	

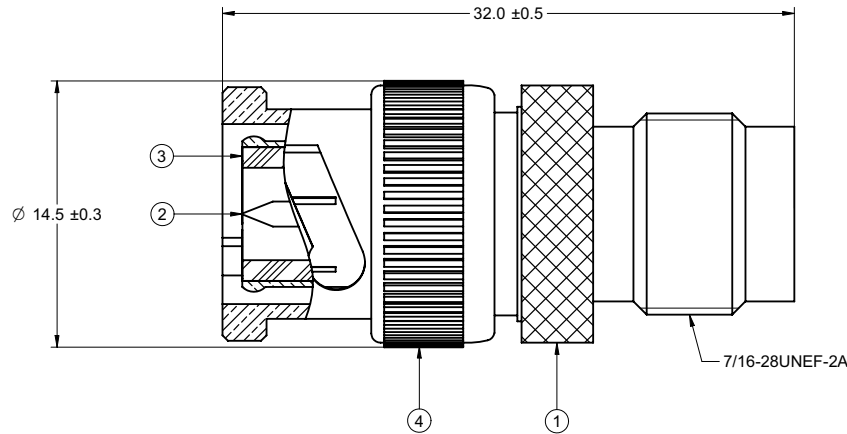

NOTES:

1. MECHANICAL SPECIFICATIONS

MATING INTERFACE: BNC 50 OHM TNC 50 OHM
 CABLE ACCEPTABILITY: N/A
 CABLE HEX CRIMP SIZE: N/A

2. ELECTRICAL SPECIFICATIONS:

IMPEDANCE: 50 OHMS NOMINAL
 DIELECTRIC WITHSTANDING VOLTAGE : 500 VRMS FOR ONE MINUTE
 WORKING VOLTAGE : 500 WVRMS
 FREQUENECY RANGE : 0-4GHZ

3. PRODUCT SHOULD BE RoHS COMPLIANCE

4. PACKAGING REQUIREMENT FOLLOWS ENGINEERING DOCUMENT P/N 836-4020001XX.

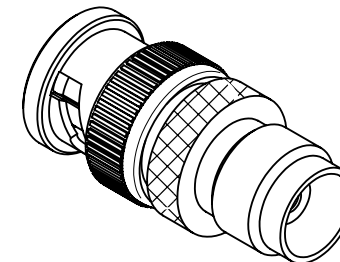

THIS DRAWING TO BE INTERPRETED
 PER ANSI Y 14.5M - 1994

COMPANY CONFIDENTIAL

TOLERANCE UNLESS OTHERWISE SPECIFIED		DRAWN BY IVON.WANG	DATE 11-08-06
DECIMALS	mm	CHECKED BY LINDA.WU	DATE 11-08-06
X	± 0.5	APPROVED BY THOMAS	DATE 11-08-06
X.X	± 0.2		
X.XX	± 0.1		
ANGLES	± 0.5°	U/M	mm

TITLE BNC PLUG TO TNC JACK ADAPTER	
SHEET 1 OF 1	DRAWING NO. CP-AD314
SIZE C	

THIS DRAWING WAS PRODUCED BY COMPUTER,
 DO NOT SCALE DRAWING OR UPDATE MANUALLY.

SHEET 1 OF 1	DRAWING NO. CP-AD314	SIZE C
-----------------	-------------------------	-----------