

XP-85B1-02D(A)-4

10Gb/s & 25Gb/s 850nm Multi-mode SFP28 Transceiver

PRODUCT FEATURES

- Supports 10.3125Gbps and 25.78G
- Maximum link length of 100m on OM4 at 25G
- Maximum link length of 400m on OM4 at 10G
- Power dissipation < 1W
- VSCSEL laser and PIN receiver
- Metal enclosure for lower EMI
- 2-wire interface with integrated Digital Diagnostic monitoring
- Hot-pluggable SFP+ footprint
- Compliant with SFF 8472
- Compliant with SFP+ MSA with LC connector
- Single 3.3V power supply
- Case operating temperature range: Commercial: 0 °C to +70 °C
Extended: 0 °C to +85 °C
Industrial: -40 °C to +85 °C

APPLICATIONS

- 10G Ethernet
- 25G Ethernet

STANDARD

- Compliant to SFF-8431
- Compliant to SFF-8472
- RoHS Compliant.

● Ordering information

Product part Number	Data Rate (Gbps)	Media	Wavelength (nm)	Transmission Distance(m)	Temperature Range (Tcase) (°C)	
XP-85B1-02D-4	10.3125G & 25.78G	Multi mode fiber	850	100	0~70	Commercial
XP-85B1-02DE-4	10.3125G & 25.78G	Multi mode fiber	850	100	0~85	Extended
XP-85B1-02DA-4	10.3125G & 25.78G	Multi mode fiber	850	100	-40~85	Industrial

I. Absolute Maximum Ratings

Parameter	Symbol	Min.	Typ.	Max.	Unit	Note
Storage Temperature	Ts	-40	-	85	°C	
Relative Humidity	RH	5	-	95	%	
Power Supply Voltage	VCC	-0.3	-	4	V	
Signal Input Voltage		Vcc-0.3	-	Vcc+0.3	V	

II. Recommended Operating Conditions

Parameter	Symbol	Min.	Typ.	Max.	Unit	Note
Case Operating Temperature	Tcase	0	-	70	°C	Commercial
		0		85	°C	Extended
		-40		85	°C	Industrial
Power Supply Voltage	VCC	3.14	3.3	3.47	V	
Power Supply Current	ICC	-		300	mA	
Data Rate	BR	-	10.3125 25.78	-	Gbps	
Transmission Distance	TD	-	-	100	m	@25G, OM4
		-	-	400	m	@10G, OM4
Coupled fiber		Multi mode fiber				

III. Optical Characteristics

1. Optical Characteristics for 10G Operation

Parameter	Symbol	Min	Typ	Max	Unit	Ref.
Transmitter						
Average Launch Power	POUT	-7.3		-0.5	dBm	1
Optical Wavelength	λ	840	850	860	nm	
Spectral Width (RMS)	σ			0.6	nm	
Optical Extinction Ratio@10.3125Gbps	ER	3.0			dB	
RIN	RIN			-128	dB/Hz	
Receiver						
Average Receive Power	RSENS	-9.9		-1.0	dBm	2
Wavelength Range	λ_C	840	850	860	nm	

Damage threshold(Min)		3.4			dBm	
LOS De -Assert	LOSD			-12	dBm	
LOS Assert	LOSA	-30			dBm	
LOS Hysteresis		0.5			dB	

Notes:

- Class 1 Laser Safety per FDA/CDRH and IEC-825-1 regulations.
- Measured with a PRBS $2^{31}-1$ test pattern, @10.3125Gb/s, BER< 10^{-12} .

2. Optical Characteristics for 25G Operation

Parameter	Symbol	Min	Typ	Max	Unit	Ref.
Transmitter						
Average Launch Power	POUT	-8.4		2.4	dBm	1
Optical Wavelength	λ	840	850	860	nm	
Spectral Width (RMS)	σ			0.6	nm	
Optical Extinction Ratio@25.78Gbps	ER	2.0			dB	
RIN	RIN			-128	dB/Hz	
Receiver						
Average Receiver Power @25.78Gb/s	R _{XMAX}	-10.3		2.4	dBm	2
Wavelength Range	λ_c	840	850	860	nm	
Damage Threshold		3.4			dBm	
LOS De -Assert	LOSD			-12	dBm	
LOS Assert	LOSA	-30			dBm	
LOS Hysteresis		0.5			dB	

Notes:

- Class 1 Laser Safety per FDA/CDRH and IEC-825-1 regulations.
- Measured with a PRBS $2^{31}-1$ test pattern, @25.78Gb/s, BER<5E-5.

IV. Electrical Characteristics

Parameter	Symbol	Min	Typ	Max	Unit	NOTE
Supply Voltage	Vcc	3.14	3.3	3.46	V	
Supply Current	Icc			300	mA	
Transmitter						
Input differential impedance	Rin		100		Ω	1
Single ended data input swing	Vin,pp	180		700	mV	
Transmit Disable Voltage	VD	Vcc-1.3		Vcc	V	
Transmit Enable Voltage	VEN	Vee		Vee+ 0.8	V	2
Receiver						
Differential data output swing	Vout,pp	300		850	mV	3
LOS Fault	VLOS fault	Vcc-1.3		VccHOST	V	4
LOS Normal	VLOS norm	Vee		Vee+0.8	V	4

Notes:

- Connected directly to TX data input pins. AC coupled thereafter.
- Or open circuit.

3. Into 100 ohms differential termination.
4. Loss Of Signal is LVTTTL. Logic 0 indicates normal operation; logic 1 indicates no signal detected.

V. Pin Descriptions

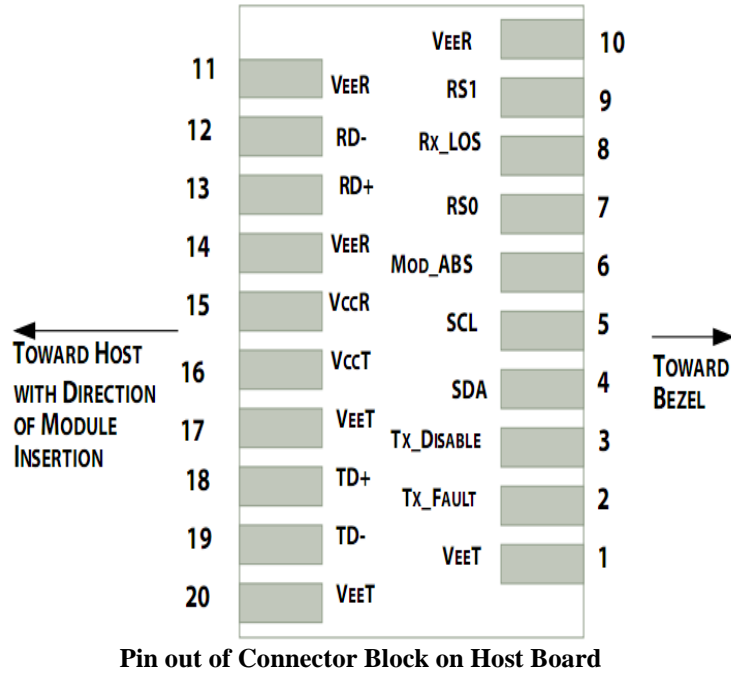

Pin	Symbol	Name/Description	NOTE
1	V_{EET}	Transmitter Ground (Common with Receiver Ground)	1
2	T_{FAULT}	Transmitter Fault.	2
3	T_{DIS}	Transmitter Disable. Laser output disabled on high or open.	3
4	SDA	2-wire Serial Interface Data Line	4
5	SCL	2-wire Serial Interface Clock Line	4
6	MOD_ABS	Module Absent. Grounded within the module	4
7	RS0	Rate Select 0	5
8	LOS	Loss of Signal indication. Logic 0 indicates normal operation.	6
9	RS1	Rate Select 1	5
10	V_{EER}	Receiver Ground (Common with Transmitter Ground)	1
11	V_{EER}	Receiver Ground (Common with Transmitter Ground)	1
12	RD-	Receiver Inverted DATA out. AC Coupled	
13	RD+	Receiver Non-inverted DATA out. AC Coupled	
14	V_{EER}	Receiver Ground (Common with Transmitter Ground)	1

15	V _{CCR}	Receiver Power Supply	
16	V _{CCT}	Transmitter Power Supply	
17	V _{EET}	Transmitter Ground (Common with Receiver Ground)	1
18	TD+	Transmitter Non-Inverted DATA in. AC Coupled.	
19	TD-	Transmitter Inverted DATA in. AC Coupled.	
20	V _{EET}	Transmitter Ground (Common with Receiver Ground)	1

Notes:

1. Circuit ground is internally isolated from chassis ground.
2. T_{FAULT} is an open collector/drain output, which should be pulled up with a 4.7kΩ– 10 kΩ resistor on the host board if intended for use. Pull up voltage should be between 2.0V to Vcc + 0.3V. A high output indicates a transmitter fault caused by either the TX bias current or the TX output power exceeding the preset alarm thresholds. A low output indicates normal operation. In the low state, the output is pulled to <0.8V.
3. Laser output disabled on T_{DIS} >2.0V or open, enabled on T_{DIS} <0.8V.
4. Should be pulled up with 4.7kΩ- 10kΩ on host board to a voltage between 2.0V and 3.6V. MOD_ABS pulls line low to indicate module is plugged in.
5. Rate select can be set by both hardware and software control. Hardware control is through the RS0 and RS1 pins as defined in SFF-8431. Software control is through I2C: A2 Byte 110 Bit 3 for RS0, and A2h Byte 118 Bit 3 for RS1. The RS0 and RS1 values from the hardware and software are logically “OR”ed. Below is the logic table.
- 6.

	Hardware Value	Software Value	Final Value	Mode of Operation
RS0	0	0	0	10G, Rx CDR bypass mode
	0	1	1	25G, Rx CDR on
	1	0	1	25G, Rx CDR on
	1	1	1	25G, Rx CDR on
RS1	0	0	0	10G, Tx CDR bypass mode
	0	1	1	25G, Tx CDR on
	1	0	1	25G, Tx CDR on
	1	1	1	25G, Tx CDR on

7. LOS is open collector output. It should be pulled up with 4.7kΩ – 10kΩ on host board to a voltage between 2.0V and 3.6V. Logic 0 indicates normal operation; logic 1 indicates loss of signal.

VI. Digital Diagnostic Functions

XGIGA XP-85B1-02D(A)-4 transceivers support the 2-wire serial communication protocol as defined in the SFP+ MSA. The standard SFP serial ID provides access to identification information that describes the transceiver’s capabilities, standard interfaces, manufacturer, and other information.

Additionally, XGIGA SFP+ transceivers provide a unique enhanced digital diagnostic monitoring interface, which allows real-time access to device operating parameters such as transceiver temperature, laser bias current, transmitted optical power, received optical power and transceiver supply voltage. It also defines a sophisticated system of alarm and warning flags, which alerts end-users when particular operating parameters are outside of a factory set normal range.

The SFP+ MSA defines a 256-byte memory map in EEPROM that is accessible over a 2-wire serial interface at the 8 bit address 1010000X (A0h). The digital diagnostic monitoring interface makes use of the 8 bit address 1010001X (A2h), so the originally defined serial ID memory map remains unchanged.

The operating and diagnostics information is monitored and reported by a Digital Diagnostics Transceiver Controller (DDTC) inside the transceiver, which is accessed through a 2-wire serial interface. When the serial protocol is activated, the serial clock signal (SCL, Mod Def 1) is generated by the host. The positive edge clocks data into the SFP transceiver into those segments of the E2PROM that are not write-protected. The negative edge clocks data from the SFP transceiver. The serial data signal (SDA, Mod Def 2) is bi-directional for serial data transfer. The host uses SDA in conjunction with SCL to mark the start and end of serial protocol activation. The memories are organized as a series of 8-bit data words that can be addressed individually or sequentially.

Alarm/Warning Threshold of TX Power & RX Power @10G & 25Gbps

TX Power High Alarm	5.4dBm
TX Power Low Alarm	-11.4dBm
TX Power High Warning	2.4dBm
TX Power Low Warning	-8.4dBm
RX Power High Alarm	5.4dBm
RX Power Low Alarm	-13.3dBm
RX Power High Warning	2.4dBm
RX Power Low Warning	-10.3dBm

VII. Host - Transceiver Interface Block Diagram

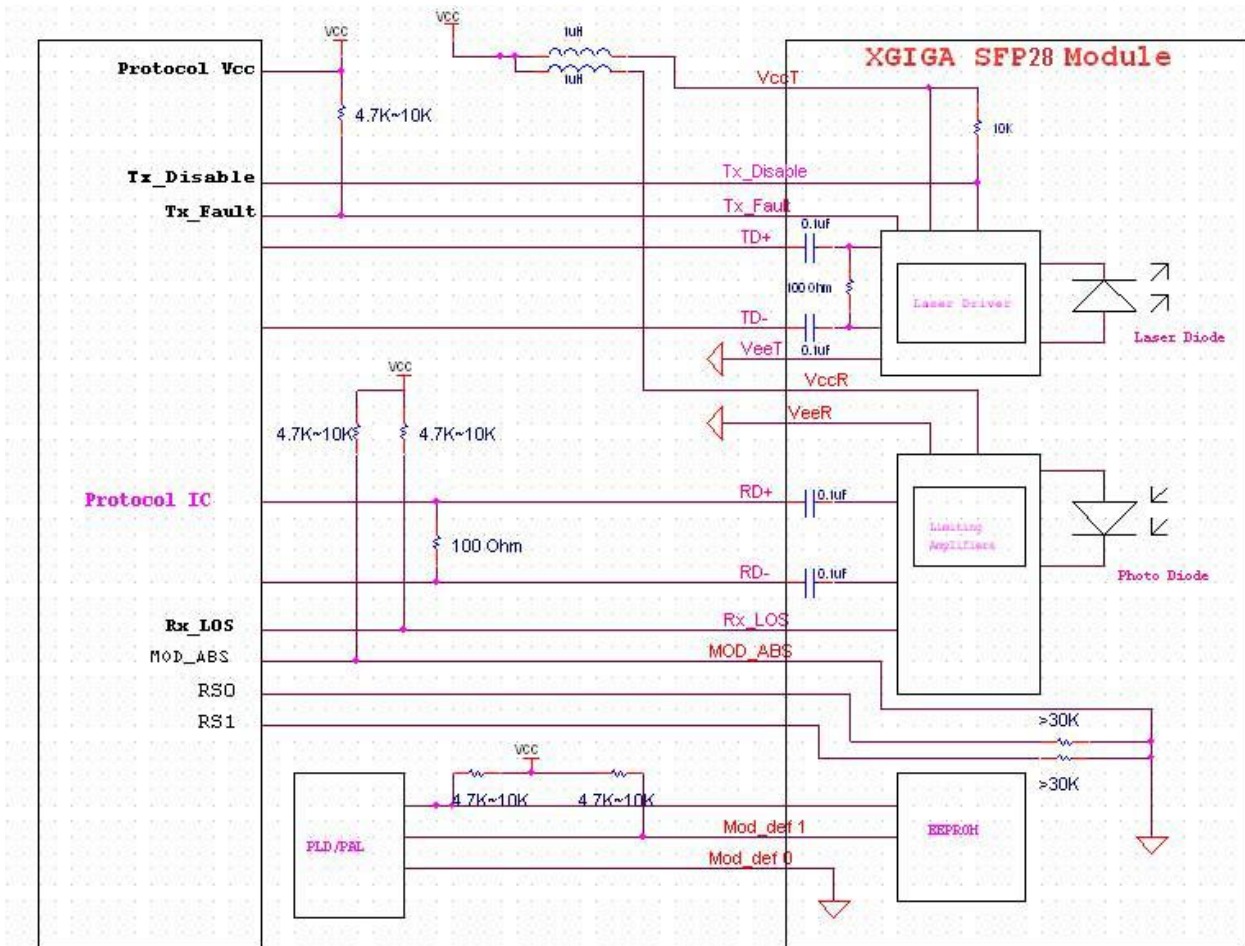

VIII. Outline Dimensions

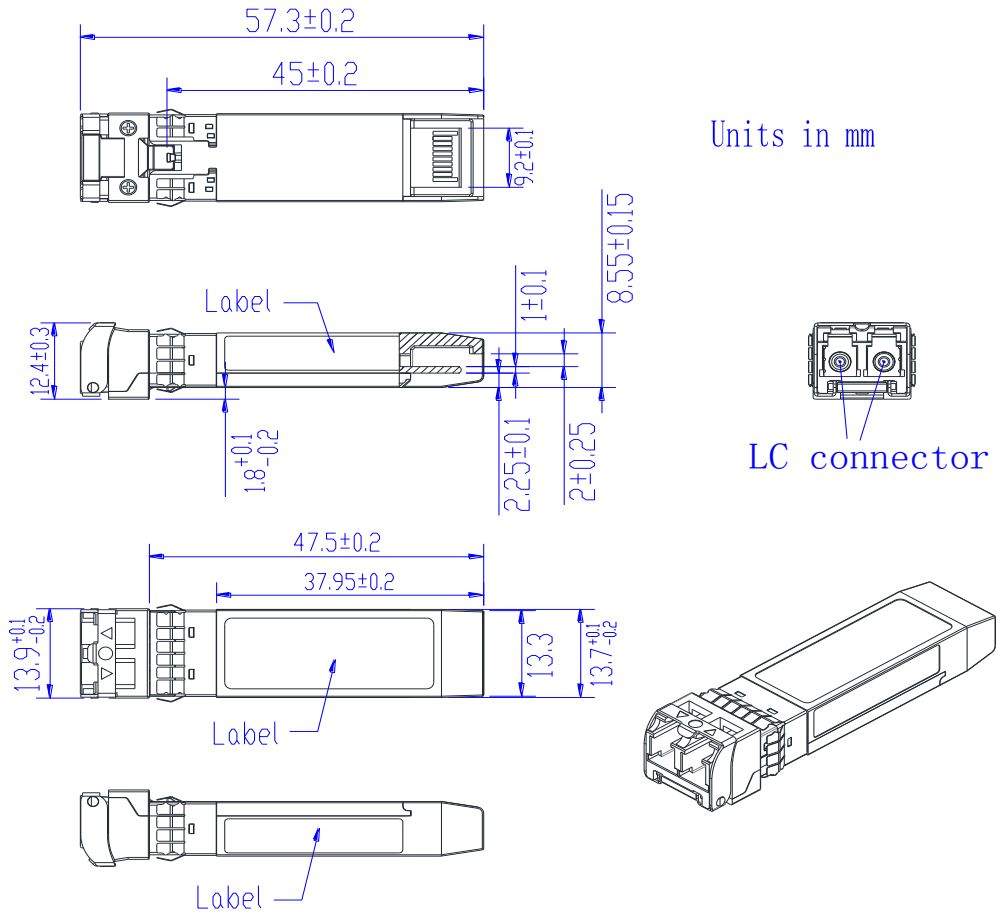

IX. Regulatory Compliance

Feature	Reference	Performance
Electrostatic discharge (ESD)	IEC/EN 61000-4-2	Compatible with standards
Electromagnetic Interference (EMI)	FCC Part 15 Class B EN 55022 Class B (CISPR 22A)	Compatible with standards
Laser Eye Safety	FDA 21CFR 1040.10, 1040.11 IEC/EN 60825-1, 2	Class 1 laser product
Component Recognition	IEC/EN 60950, UL	Compatible with standards
ROHS	2011/65/EU and (EU)2015/863	Compatible with standards
EMC	EN61000-3	Compatible with standards

Appendix A. Document Revision

Version No.	Date	Description
1.0	2021-05-13	Preliminary datasheet
2.0	2021-08-19	Add the spec of Optical Characteristics for 10G Operation

3.0	2022-02-18	Add industrial PN XP-85B1-02DA-4
4.0	2022-05-06	Update power dissipation max from 1.2W to 1W.
5.0	2022-11-08	Add E-temp part number XP-85B1-02DE-4