

This document is the property of Amphenol Corporation and is delivered on the express condition that is not to be disclosed, reproduced or used, in whole or in part, for manufacture or sale by anyone other than Amphenol Corporation without its prior consent, and that no right is granted to disclose or to use any information in this document.
The marking on this product doesn't contain environmental hazardous materials per Material Specification 55-00259 for Sony GP compliant or per directive 2011/65/EU for RoHS compliant.

REVISIONS				
SYM	ECN No.	DESCRIPTION	DATE	APPROVED
A	NE-16275	TO PRODUCTION	12/05/2016	Roger Tsai

ORIGINAL

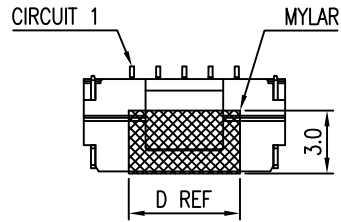

P/N: G880 XX 2 X X C1HR
 NO. OF POS. _____ COLOR
 1. BLACK
 2. NATURAL
 CONTACT FINISH
 1. 100μ" MATTE TIN
 PACKING
 1. TAPE & REEL

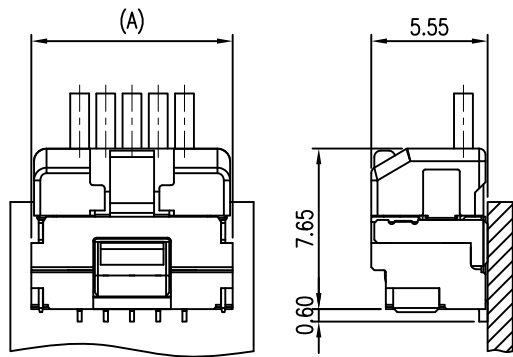
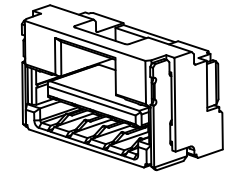

MATED CONNECTOR

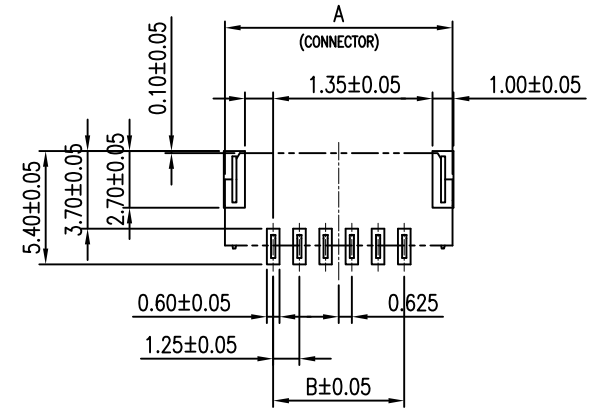
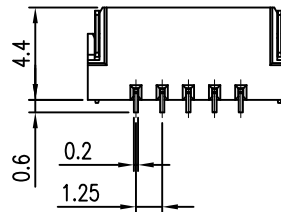
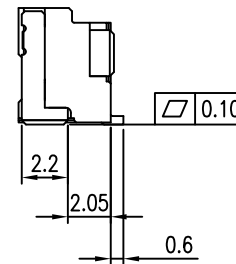
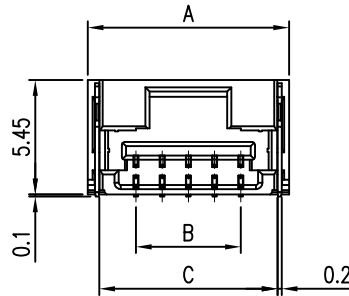

RECOMMENDED PCB LAYOUT
 ALL TOLERANCE ARE ±0.05

NOTES:

- INSULATOR: HIGH TEMPERATURE THERMAL PLASTIC, NYLON 6T, UL 94V-0, COLOR: OPTION.
- CONTACT: COPPER ALLOY, SELECTIVE PLATING ON CONTACT AREA, 100μ" MIN. MATTE TIN OR GOLD FLASH PLATING ON SOLDERING AREA, UNDER 50μ" MIN. NICKEL UNDER-PLATING OVERALL.
- THIS PRODUCT DOESN'T CONTAIN ENVIRONMENTAL HAZARDOUS MATERIAL PER DIRECTIVE 2011/65/EU FOR RoHS.
- PACKING MUST BE PER Amphenol PACKING SPECIFICATION PKS-0001
- PRODUCT SPECIFICATION REFER TO : PS-7582.
- TEST SUMMARY REFER TO : TS-7582-002.

G880 07 2XXX C1HR	7	12.10	7.50	11.00	5.3
G880 06 2XXX C1HR	6	10.85	6.25	9.75	5.3
G880 05 2XXX C1HR	5	9.60	5.00	8.50	5.3
G880 04 2XXX C1HR	4	8.35	3.75	7.25	5.3
G880 03 2XXX C1HR	3	7.10	2.50	6.00	5.3
G880 02 2XXX C1HR	2	5.85	1.25	4.75	5.3

PART NUMBER	NO. OF POSITIONS	DIMENSIONS			
		A	B	C	D

TOLERANCE	APPROVALS	DATE	TITLE		PART No.	
X. ±0.30	DRAWN Aqua Chou	12/05/2016	G880 SERIES, WTB CONN 1.25 PITCH, R/A SMT TYPE		Amphenol® Amphenol Corporation Amphenol Taiwan Corporation	
X.X ±0.20	CHECKED Roger Tsai	12/05/2016				
X.XXX ±0.10	APPROVED Roger Tsai	12/05/2016	UNIT mm		SIZE A3	PART No. G880XX2XXXC1HR
ANGULAR ±1°	DWG TYPE CUST DWG	PROJECT CODE PHD	SCALE NA	SHEET 1 OF 2	DWG No. G880XX2XXXC1HR	REV. A
UNLESS OTHERWISE SPECIFIED						

This document is the property of Amphenol Corporation and is delivered on the express condition that it is not to be disclosed, reproduced or used, in whole or in part, for manufacture or sale by anyone other than Amphenol Corporation without its prior consent, and that no right is granted to disclose or to use any information in this document.

The marking on this product doesn't contain environmental hazardous materials per Material Specification 55-00259 for Sony GP compliant or per directive 2011/65/EU for RoHS compliant.

REVISIONS				
SYM	ECN No.	DESCRIPTION	DATE	APPROVED
A	NE-16275	TO PRODUCTION	12/05/2016	Roger Tsai

ORIGINAL

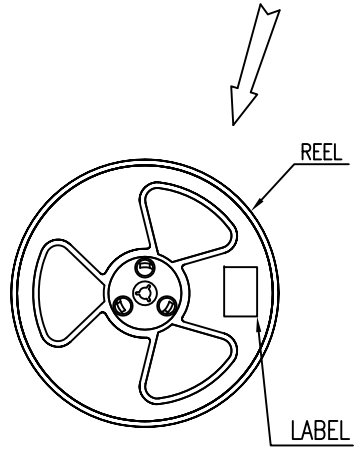
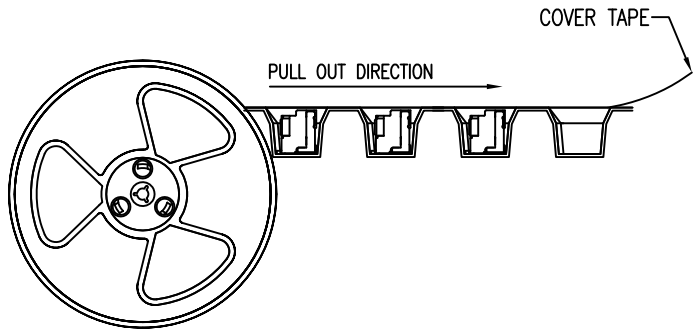
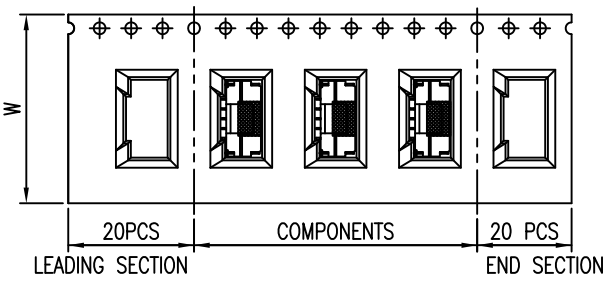

Pos.	W	PCS/Reel	PCS/Carton	Net (Kg)	Gross (Kg)
2	16.0	900	8100	1.28	5.02
3		900	5400	1.02	4.38
4		900	5400	1.15	4.51
5	24.0	900	5400	1.31	4.67
6		900	5400	1.47	4.83
7		900	5400	1.63	4.99

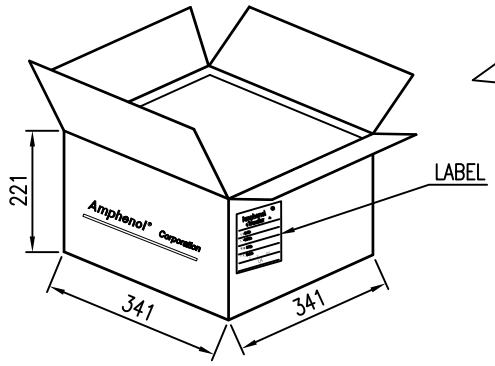

TOLERANCE		APPROVALS		DATE	TITLE		Amphenol®						
X.		DRAWN	Aqua Chou	12/05/2016	G880 SERIES, WTB CONN 1.25 PITCH, R/A SMT TYPE		Amphenol Corporation Amphenol Taiwan Corporation						
X.X	±0.30	CHECKED	Roger Tsai	12/05/2016									
X.XX	±0.20	APPROVED	Roger Tsai	12/05/2016									
X.XXX	±0.10						UNIT	mm	SIZE	A3	PART No.	G880XX2XXXC1HR	
ANGULAR	±1°	DWG TYPE		CUST DWG	PROJECT CODE		SCALE	NA	SHEET	2 OF 2	DWG No.	G880XX2XXXC1HR	
UNLESS OTHERWISE SPECIFIED											REV.	A	