

PART NUMBER: FLH - SX3 - 9X - X

SERIES
FLH

SOCKET HOUSING TYPE

S1 = 1 CONTACT
S2 = 2 CONTACTS
S3 = 3 CONTACTS
S4 = 4 CONTACTS
S5 = 5 CONTACTS
S6 = 6 CONTACTS

IDENTIFIER

XX = 90 FOR IP20
= 01-99 FOR OTHER IP20 OPTIONS

OTHER FEATURES

LEAVE BLANK FOR STANDARD
0 TO 9 FOR OTHER OPTIONS

SOCKET HOUSING	W (mm)
S1	
S2	10.30
S3	
S4	
S5	17.80
S6	

REVISIONS			
REV	DESCRIPTION, ECN, EAR NO.	DATE	APP'D
A	PRODUCT DWG - NEW PER EAR 15058	JUL25/22	S.M.
B	PRODUCT DWG - REV PER EAR 15058	AUG10/22	S.M.

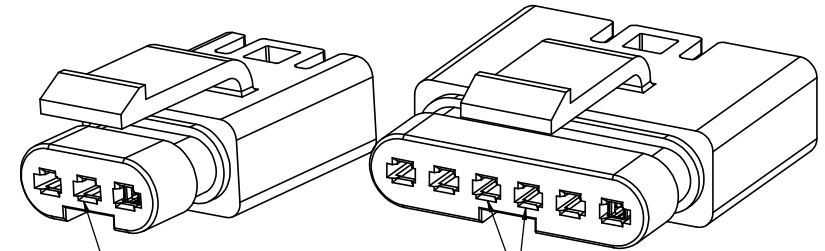

MIDDLE POSITION VACANT
FOR 2 POSITION CONNECTOR

MIDDLE 2 POSITIONS VACANT
FOR 4 POSITION CONNECTOR

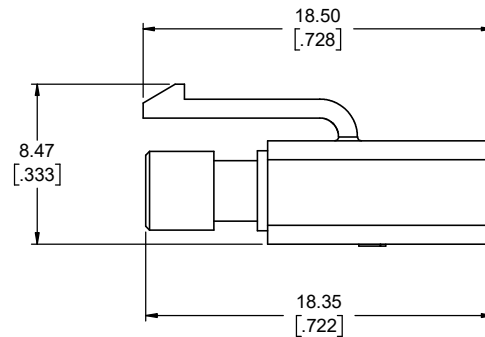
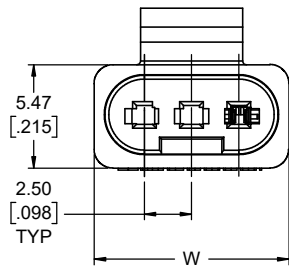

3.50±0.25
[.138±.010]



NOTES:

- MATERIALS:** ALL MATERIALS ARE RoHS COMPLIANT PER EU DIRECTIVE 2011/65/EU & AMENDMENTS
 - HOUSING: ENGINEERING THERMOPLASTIC, UL FLAMMABILITY RATING 94V-0, COLOR BLACK
 - CONTACTS: COPPER ALLOY PLATED WITH TIN OVER NICKEL
- ELECTRICAL CHARACTERISTICS**
 - CURRENT RATING: 7A (18 AWG OR 1 mm²) OR 5A (20 AWG OR 0.5 mm²) OR 3A (22 AWG OR 0.34 mm²) PER CONTACT
 - DIELECTRIC WITHSTANDING VOLTAGE: 1500 VAC
 - INSULATION RESISTANCE: 500 MEGAOHMS
 - OPERATING TEMPERATURE: -40°C TO +105°C
- WIRE STRIP LENGTH 3.5±0.25 MM. SOLID WIRE REQUIRED, INSULATION DIAMETER 1.8 MM MAX.
- ENVIRONMENTAL PROTECTION: IP20 PER IEC 60529

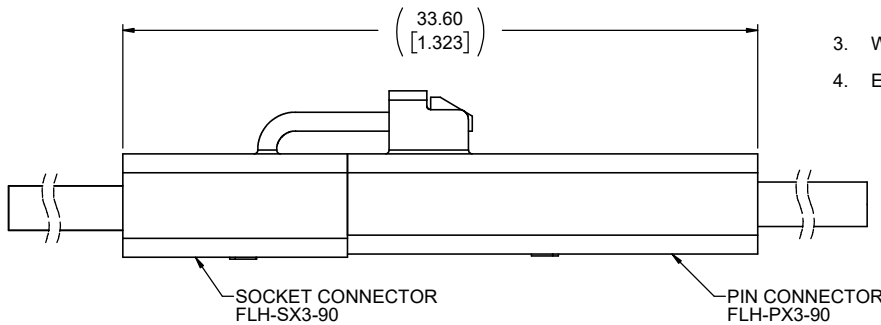

MATED ASSEMBLY VIEW

UNLESS SPECIFIED OTHERWISE	DRAWN	S.MUGAN	JUL25/22
PRIMARY UNITS MILLIMETERS	CHECKED		
SECONDARY UNITS INCHES	M.E. APP'D		
REFERENCE IN PARENTHESES	O.A. APP'D		
GENERAL TOLERANCES	DWG APPR.		
1 DECIMAL PLACE	ENG. REL. NO. EAR 14964		
2 DECIMAL PLACES ±0.10	REF.		
3 DECIMAL PLACES	THIRD ANGLE PROJECTION		
ANGULAR DEGREES	DO NOT SCALE DRAWING		

Amphenol Canada Corp.
Commercial Products

FLH SERIES, 2.5mm PITCH, POKE IN
PLUG ASSEMBLY,
1 TO 6 CONTACT OPTIONS,
RoHS COMPLIANT

DWG. NO. **P-FLH-SX3-9X-X** REV **B**

CODE ID NO. 03554 DWG SIZE: X SCALE: 5:1 SHEET 1 OF 1