

Technical Description

# Universal Motor Controller UMC100-FBP



Power and productivity  
for a better world™



---

# Universal Motor Controller

## UMC100-FBP

### Technical Description

---

#### Please note the following

##### Target group

This description is intended for use by trained specialists in electrical installation and control and automation engineering, who are familiar with the applicable national standards.



##### Safety requirements

The responsible staff must ensure that the application or use of the products described satisfy all the requirements for safety, including all the relevant laws, regulations, guidelines and standards.

#### Using this Handbook

##### Symbols

This technical document contains markers to point the reader to important information, potential risks and precautionary information. The following symbols are used:

	Symbol to indicate a potentially dangerous situation that can cause damage to the UMC or connected devices or to the environment
	Symbol to indicate important information and conditions.
	Symbol that indicates a potentially dangerous situation that can cause personal injury

##### Abbreviations

UMC	Universal Motor Controller
DCS	Distributed Control System
PLC	Programmable Logic Controller
GSD	Device description file for PROFIBUS networks
EDS	Device description file for DeviceNet networks
FDT/DTM	Device driver technology for field devices. Specified from the FDT group.
NC / NO	Normal closed / Normally open
FBP	FieldBusPlug is the name for a group of products which allows to connect ABB low voltage control products to different fieldbuses.

##### Related Documents

Technical Documentation	Document No.
DTM manual for FBP devices	2CDC 192 012 D02xx
Manual of the custom application editor	2CDC 135 014 D02xx

---

# Universal Motor Controller

## UMC100-FBP

### Technical Description

---

#### Content

New features in comparison to preceeding versions .....	7
1 System Overview.....	9
Function Overview .....	9
Compatibility to UMC22 .....	10
Description of Components.....	11
2 Installation .....	17
Assembly and Disassembly of UMC100-FBP and IO Modules .....	17
Connecting the IO Modules DX111 and DX122 .....	17
Wiring DX1xx Inputs and Outputs .....	18
Connecting the VI15x Voltage Module .....	19
Wiring VI15x Inputs and Outputs.....	20
Connecting the VI15x Voltage Module and a DX1xx IO Module .....	20
Connecting Contactors.....	21
Motor Wiring .....	23
Connecting External Current Transformers (CTs) .....	24
Connecting the UMC100-PAN LCD Panel .....	26
Using the UMC100 in a PROFIBUS DP Network .....	27
Using the UMC100 in a DeviceNet Network .....	28
Using the UMC100 in a CANopen Network .....	29
Using the UMC100 in a MODBUS RTU Network .....	30
Usage in Draw-Out Systems .....	31
3 Commissioning.....	33
Commissioning Steps.....	33
Test Position .....	35
4 Configuring the Motor Protection Functions.....	37
General Information .....	37
EOL and Current based Protection Functions.....	37
Earth Fault Protection .....	47
Thermistor (PTC) Motor Protection acc. to EN 60947-8 (type A sensors).....	49
Resistive Thermal Device (RTD) based Motor Protection.....	49
Voltage and Power Protection Functions .....	50
Total Harmonic Distortion .....	52
Voltage Dips, Load Shedding .....	55
5 Configuring the Motor Management Functions .....	59
Starting and Stopping the Motor.....	59
Limit the Number of Starts .....	64
Emergency Start .....	64
Checkback Monitoring .....	66

---

# Universal Motor Controller

## UMC100-FBP

### Technical Description

---

Using the Digital UMC Inputs .....	66
Control Function Transparent .....	69
Control Function Overload Relay.....	71
Control Function Direct Starter (DOL).....	73
Control Function Reversing Starter (REV).....	76
Control Function Star-Delta Starter .....	79
Control Function Pole-Changing Starter .....	82
Control Function Actuator 1 - 4.....	85
6 Configuring the Fieldbus Communication.....	91
Setting the Bus Address.....	91
Address Check when using UMC in Motor Control Centres.....	91
Defining the Bus Fault Reaction .....	92
Ignore Block Parameters .....	93
7 Using Expansion Modules.....	95
Using a Digital IO Module (DX111/122) .....	95
Using a Voltage Module (VI150/155).....	96
8 The LCD Control Panel UMC100-PAN.....	97
Overview .....	97
Monitoring Status Information .....	98
The Menu Tree .....	98
Adjusting Parameters .....	104
Starting and Stopping the Motor.....	106
9 Error Handling, Maintenance and Service.....	109
Error Handling of the UMC .....	109
UMC100 Fault Indication.....	109
Fault Messages.....	109
Resetting Parameters to Factory Defaults .....	114
Resetting the Password.....	114
Reading, Setting and Resetting Maintenance Counters .....	115
DX1xx / VI15x Status Codes .....	116
Replacing a UMC100.....	116
Replacing a DX1xx IO Module.....	116
Replacing a VI15x Module.....	116
Requesting Support.....	116
A1 Parameters and Data Structures on a Fieldbus.....	117
Command Data .....	117
Accessing Data on PROFIBUS.....	119
Accessing Data on Modbus .....	119
Accessing Data on DeviceNet .....	119
Accessing Data on CANopen .....	119
Parameter Organisation.....	120

---

# Universal Motor Controller

## UMC100-FBP

### Technical Description

---

Motor Management Parameters.....	120
Protection Parameters.....	125
Communication Parameters.....	129
IO Module Parameters.....	129
UMC Display Parameters .....	133
Function Block Related Parameters.....	134
All Parameters Sorted by Parameter Number .....	135
All Parameters Sorted Alphabetically .....	137
A2 Circuit Diagrams with Emergency Stop Function .....	139
Direct Starter, Category 4 .....	139
Reversing Starter, Category 4.....	140
A3 Technical Data.....	141
UMC100.....	141
Performance Data.....	146
UMC100-PAN .....	146
DX111 and DX122 .....	146
VI150 and VI155.....	150
EMC UMC100 and DX1xx / VI15x Modules .....	151
Dimensions UMC100.....	152
Dimensions Expansion Modules .....	153
Dimensions LCD Panel.....	153

---

# Universal Motor Controller

## UMC100-FBP

### Technical Description

---

#### How to get started

There are many options for using the UMC100. Not all functions are required in all cases. Therefore the documentation is split into separate parts. You only need to read the parts that are relevant for your application.

The following manuals exist.



#### **UMC100-FBP Technical Manual** **2CDC 135 013 D02xx<sup>1</sup>**

This is the main technical description and must always be read carefully before using the UMC.



You are now reading this manual



#### **PBDTM** **2CDC 192 012 D02xx<sup>1</sup>**



This manual describes the configuration tool (Device Type Manager) that can be used to configure and monitor the UMC100 and also other ABB control products like UMC22, softstarters and circuit breakers. It is based on the standardised FDT/DTM technology.

If you plan to only configure the UMC100 with the device description files like GSD (for PROFIBUS) or EDS (for CAN) or via the LCD panel, you do not need to read this manual.



#### **UMC100-FBP Custom Application Editor** **2CDC 135 014 D02xx<sup>1</sup>**



This manual describes how to create customer-specific applications for the UMC100.

You only need to read this manual, if the logic built into the UMC100 does not fulfill your needs.

As the custom application editor is part of the configuration tool (Device Type Manager), it is highly recommended that you read the PBDTM manual first



#### **FieldBusPlugs**

Whenever the UMC100 is to be connected to a fieldbus, read the appropriate FieldBusPlug manual.

Presently the following FieldBusPlugs can be used together with UMC100:

- PROFIBUS DP    PDP22    **2CDC 192 001 D02xx<sup>1</sup>**  
                                         PDQ22    **2CDC 192 009 D02xx<sup>1</sup>**
- DeviceNet        DNP21    **2CDC 193 001 D02xx<sup>1</sup>**
- CANopen         COP21    **2CDC 194 002 D02xx<sup>1</sup>**
- MODBUS RTU    MRP21    **2CDC 194 001 D02xx<sup>1</sup>**

---

<sup>1)</sup> please replace xx with the latest version (e.g. 02). Consult your local sales representative, if you are unsure regarding the latest version.

---

# Universal Motor Controller

## UMC100-FBP

### Technical Description

---

#### New features in comparison to preceding versions

1SAJ520000R0100 -> 1SAJ520000R0101

##### New Protection Functions

The new voltage modules VI150 and VI155 can be connected. These modules add voltage and power based protection and supervision functions as well as energy measurement to the UMC100. See section 4 -> *Voltage and Power Protection Functions* for details.

The UMC100 now supports the internal detection of an earth fault situation without using an external summation current transformer.

##### New Motor Management Functions

The number of available TOn, TOff, RS and SR function blocks had been increased. See manual 2CDC 135 014 D02xx for more details.

The number of starts per time interval can be limited. A warning is signalled if just one start is left.

##### Other new Functions

The LCD panel supports up - and download of parameters or applications or both. See section 8 for details.

The LCD panel supports Russian as an additional language

The absolute motor current is available in the function block application and can be cyclically transferred to the control system for example.

The status of the fieldbus communication is available in the function block application

The motor operation hours can be set



The new UMC100 version is fully backwards compatible with the previous version and replaces it.

To use the new features via fieldbus new fieldbus device description files have to be used. Therefore updated GSD and EDS files are available on the ABB web site. See section A1 for details.

---

**Universal Motor Controller  
UMC100-FBP  
Technical Description**

---

---

# Universal Motor Controller

## UMC100-FBP

### Technical Description

---

## 1 System Overview

The Universal Motor Controller (UMC) is an intelligent motor controller for 3-phase AC induction motors combining the two classical functions of motor protection and motor management in a single device plus offering diagnostic and fieldbus communication. The device functions can be adjusted in a wide range to cover the needs of different industries. UMC100 is a further development of the UMC22.

### Function Overview

#### Protection Functions

- The UMC provides comprehensive motor protection including phase failure detection, adjustable motor protection for stalled motors during startup or normal operation, configurable current limits to generate trips or warnings and many more.
- Overload classes 5E, 10E, 20E, 30E and 40E
- Thermistor motor protection (PTC)
- Earth fault detection (e.g. when used in IT networks)
- Power and voltage based protection functions
- Supervision of the network quality (Total Harmonic Distortion)
- One device type covers the whole current range starting from 0.24 up to 63 A.  
For higher currents up to 850 A additional current transformers are available.

#### Fieldbus Communication

- The UMC100 can be integrated into different fieldbus networks such as PROFIBUS DP, DeviceNet, MODBUS and CANopen via the FieldBusPlug interface. All measured data, status signals and parameters can be accessed via fieldbus.
- It is also possible to use the UMC100 as a stand-alone device without the FieldbusPlug communication.
- The motor protection and motor management is fully functional in the event of a bus failure.
- The fieldbus interface and the UMC can be separated. This offers many benefits in MCC applications especially for withdrawable systems.
- Parameterisation of the protection and control functions can be carried out with the device description files as defined by the different fieldbuses (e.g. GSD for PROFIBUS). In addition a Device Type Manager (DTM) offering a very convenient device configuration via a laptop or within a control system is also available.

#### Motor Management, Inputs and Outputs

- The UMC100-FBP provides six digital inputs, three relay outputs and one 24 V output. Therefore a wide number of control functions can be covered from the base device.
- If further inputs or outputs are needed, the basic device can be expanded with an expansion module. That provides an additional eight digital inputs, four relay outputs and an analogue output for driving an analogue meter.
- Supported standard configurations are direct starter, reversing starter, star-delta starter, actuator, inching mode and many more.
- The digital inputs can be configured in many ways to adapt the behaviour of the UMC100 to specific user requirements.
- To execute customer specific applications the UMC100 allows free programming of its internal logic. Function blocks for signal adjustment, boolean logic, timers, counters ... are available (see below).
- Different control stations (DCS, DI, Operation Panel ...) with individual, adjustable release opportunities are available.

---

# Universal Motor Controller

## UMC100-FBP

### Technical Description

---

#### Metering, Monitoring and Diagnosis

- Rapid, comprehensive diagnostics and operating status information is available on the UMC100 itself (LEDs), on the LCD panel (clear text messages), via fieldbus or on a laptop connected directly or via fieldbus to the UMC.
- The fully graphic, multi-language LCD panel allows configuration, control and monitoring of the UMC and its inputs and outputs.
- Available diagnosis includes motor, bus and device status, maintenance counters such as number of starts and overload releases, remaining cooling time, etc.

#### Function Block Programming

- The UMC100 has a set of predefined applications built in. These applications are built on the basis of function blocks and can be used directly without the need for a programming tool.
- Custom applications can be created in a convenient way. The custom application editor is integrated in the configuration tool.
- You can monitor an application online to support you during development and testing.
- Control and protection related and general purpose function blocks are available: boolean logic, timers, counters, blocks representing the hardware, starter functions, ...
- There are basic function blocks like boolean blocks that have no parameters. But there are also very powerful function blocks such as the multifunction inputs or the starter blocks. Such blocks have parameters accessible via LCD operator panel and fieldbus. By setting the block parameters you can adjust the behaviour of the blocks and the application to your needs.



Please note: It is not necessary to change the function block application if the predefined applications fulfill your requirements. But if you have specific requirements you can enable the customer application mode and adapt an existing application to your needs or even create your own one. This is described in the custom application editor manual (see section 'How to get started').

#### Compatibility to UMC22

##### Hardware

The UMC100 is mechanically compatible with the UMC22. The UMC100 does not need more space and can be used in all situations the UMC22 was used in.

Please note that terminal 12 was previously a static 24 V output. In UMC100 it is now a switchable 24 V output that can signal a protection trip for example.

##### Fieldbus Interface

Both devices follow the PNO profile for motor starters regarding their cyclic command and monitoring telegram. This means the first two bytes within the cyclic telegrams are the same in both devices. But as the UMC100 provides many new functions, the command and monitoring telegrams are now longer, so that additional data can be transferred e.g. the status of the inputs of a connected expansion module.

To configure the new functions also the number and organisation of the parameters have changed. This means that the UMC100 looks different from a control system integration perspective.



It is not possible to just replace the UMC22 with a UMC100. Changes in the device integration package is necessary.

# Universal Motor Controller

## UMC100-FBP

### Technical Description

#### Description of Components

#### UMC100-FBP

The following diagram shows the terminals, monitoring and operating elements of the UMC100-FBP

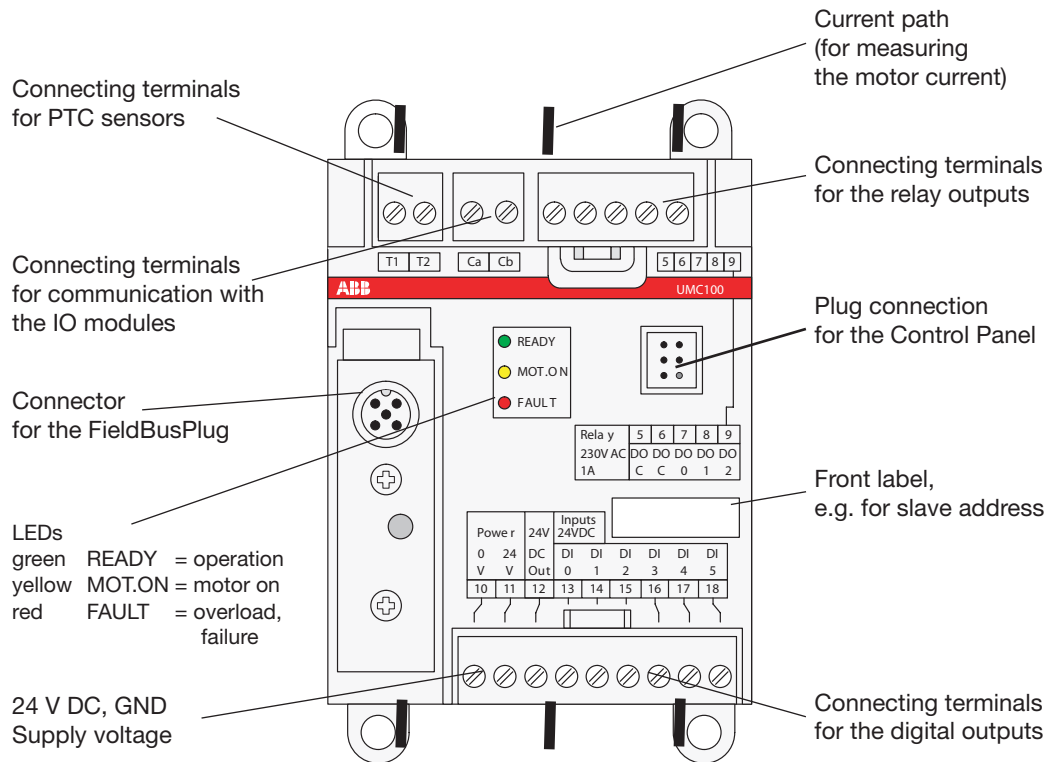

After powering on, the UMC100 performs a self-test of its hardware and checks the configuration for consistency.

In the event of a failure, a self-test fault is generated and signalled. Replace the device in such a case.

After a successful self-test the UMC enters the operational state.

# Universal Motor Controller

## UMC100-FBP

### Technical Description

#### Building Blocks of UMC100-FBP

The next diagram shows the major function blocks of the UMC100 and the data flow among them.

The upper main block contains the protection-related functions. Signals from different signal sources are evaluated from the trip unit. Depending on the configuration either a trip or a warning can be created. The motor protection always has priority regarding control of the relay outputs. In case of a protection trip the relevant contacts are opened and thereafter the motor is stopped. If the device fails, the watchdog opens the relay outputs automatically for safety reasons. There is no possibility to bypass this watchdog.

The main inputs for motor protection are the current measurement and the thermistor sensor. The current measurement provides information about the actual motor current in the three phases. An advanced motor model uses the current information and calculates the corresponding motor temperature. At a certain level it will trigger an overload trip.

The thermistor input measures the PTC resistance. Based on the resistance the cold and hot state of the motor can be distinguished. Also short-circuit or wire break conditions can be detected.

The lower main block contains the control-related functions. Incoming commands from the panel, the digital inputs or the fieldbus are ranked from the control place selection block according to the user settings and then forwarded to the active starter function.

The starter function block controls the relay outputs depending on its input signals and the actual state. Additionally monitoring signals are prepared for the LCD display, the UMC100 signalling LEDs and the fieldbus monitoring and diagnosis telegrams.

All these blocks run in the so-called logic engine. It is possible to change the application which is running there but usually the predefined applications will be sufficient. Further information about the creation of custom applications can be found in the Custom Application Editor manual.

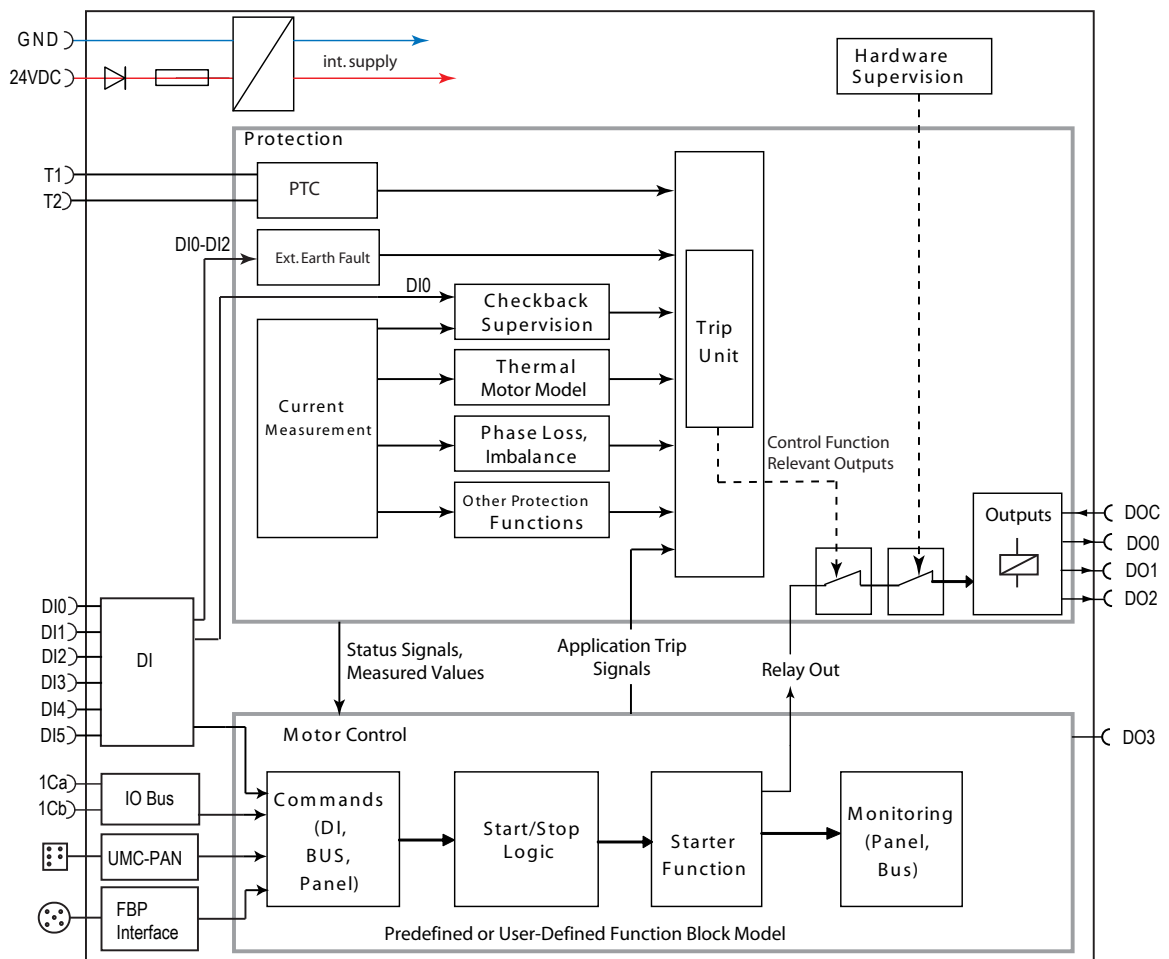

▲ Overview of the major building blocks of UMC100-FBP and the data flow among them.

# Universal Motor Controller

## UMC100-FBP

### Technical Description

#### DX111-FBP

The DX111-FBP expands the input and output channels of the UMC100. It provides eight digital inputs for 24 V DC, four relay outputs and a current output to drive an analogue instrument.

The following diagram shows the terminals and monitoring elements of the DX111-FBP module.

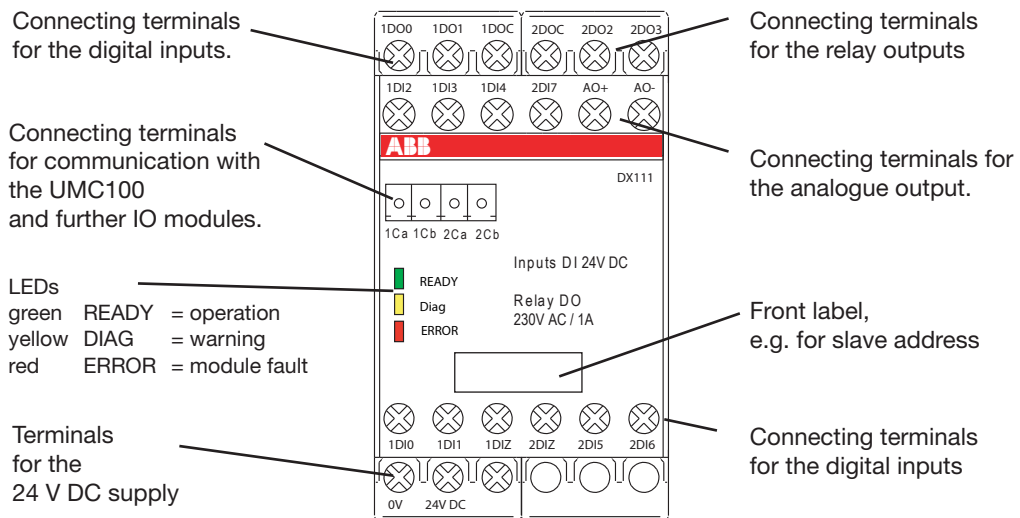

#### DX122-FBP

The DX122-FBP expands the input and output channels of the UMC-FBP. It provides eight digital inputs 110 V AC - 230 V AC, four relay outputs and a current output to drive an analog instrument.

The following figure shows the terminals and monitoring elements of the DX122-FBP module.

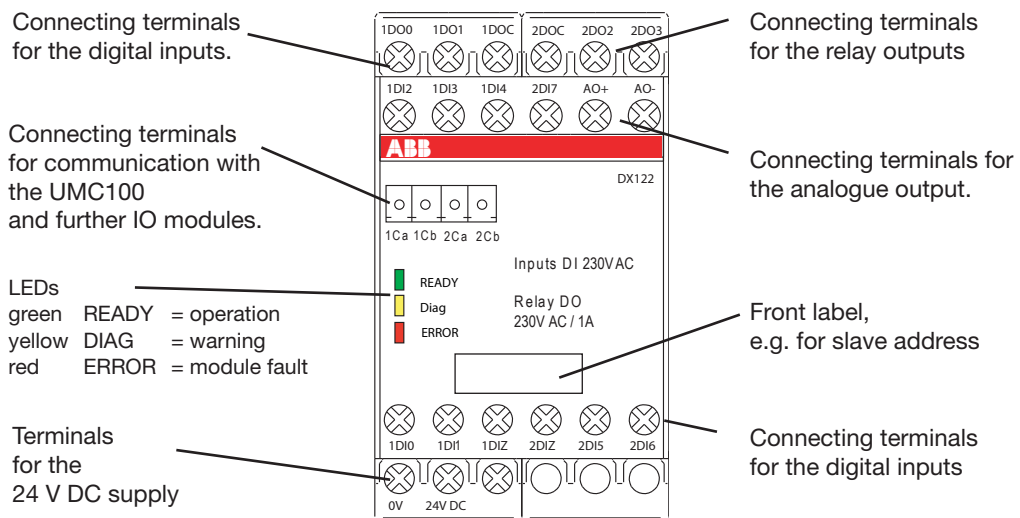

# Universal Motor Controller

## UMC100-FBP

### Technical Description

#### VI150-FBP

The VI150-FBP adds voltage and power protection functions to the UMC-FBP. It provides three voltage inputs with a nominal range from 150 V AC - 690 V AC and one relay output.



The module can be used with grounded systems only (e.g. TN-C / TN-S systems according to IEC 60364).

The following figure shows the terminals and monitoring elements of the VI150-FBP module.

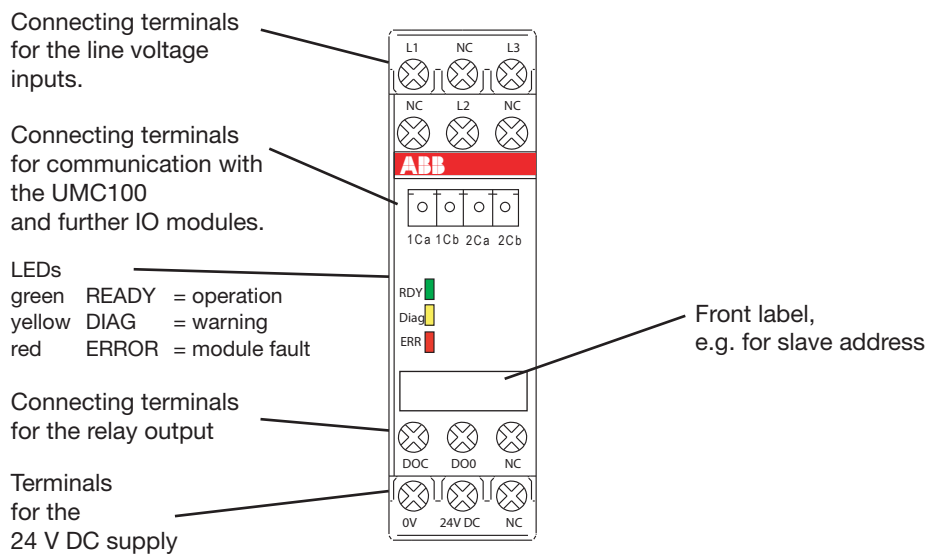

#### VI155-FBP

The VI155-FBP adds voltage and power protection functions to the UMC-FBP. It provides three voltage inputs with a nominal range from 150 V AC - 690 V AC and one relay output.



The module can be used with grounded and ungrounded systems (e.g. TN or IT-systems according to IEC 60364).

The following figure shows the terminals and monitoring elements of the VI155-FBP module.

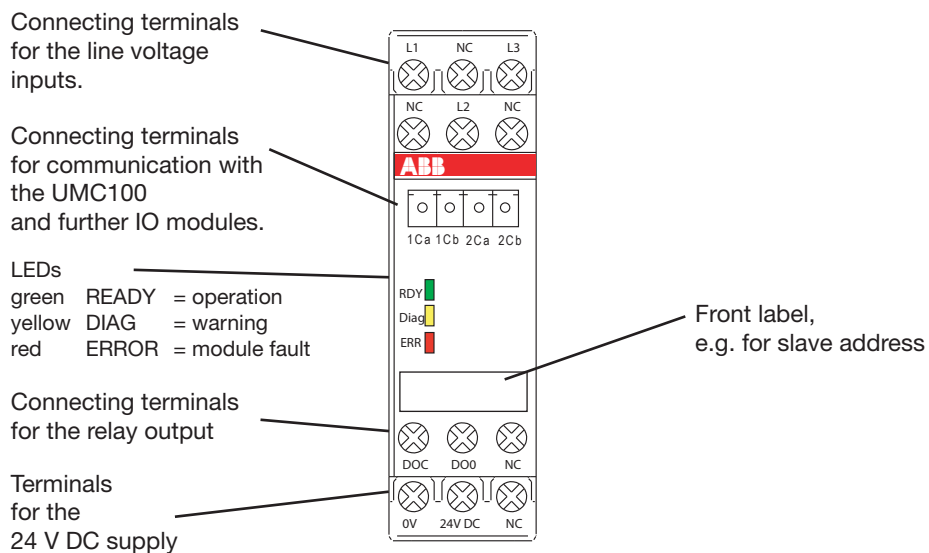

# Universal Motor Controller

## UMC100-FBP

### Technical Description

#### Configuration Tool

Asset Vision Basic is the tool to configure the UMC100-FBP via a Laptop. Asset Vision Basic is jointly used between ABB Instrumentation and ABB Control Products. Therefore it enables a wide range of ABB products to be configured such as motor controllers, soft starters, flow meters and many more.

It is based on the FDT/DTM standard which also enables the configuration of third-party products that are connected at the same bus segment.

You can parameterise the UMC100-FBP both online and offline.

In offline mode the configuration can be fully prepared and then later on loaded into the device(s).

If a connection to a device exists, online-monitoring of all measured values, maintenance counters etc. is possible.

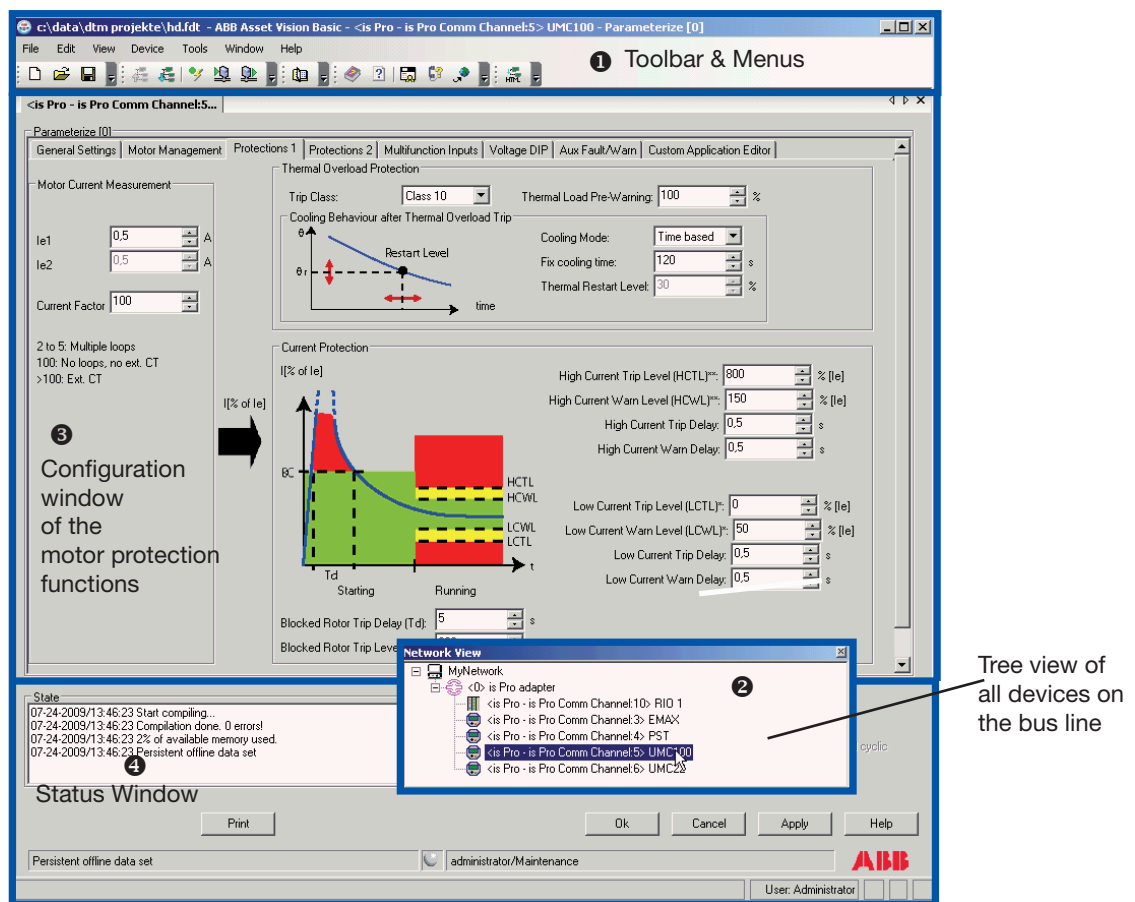

- ▲ UMC100-FBP configuration tool Asset Vision Basic with the motor protection configuration window (3). In (1) the toolbar of the tool is shown. (2) provides a network view with all the devices accessible on the PROFIBUS DP line. (4) contains a window to display messages and buttons to quit or adopt the parameter changes.

The diagram above shows the configuration tool which allows intuitive configuration of all UMC100 functions.

In this example the window to configure the motor protection parameters is shown.

In similar windows all other parameters can be configured.

Other views enable the monitoring of the diagnosis information, the visualisation of bus monitoring, command data and much more.

# Universal Motor Controller

## UMC100-FBP

### Technical Description

#### UMC100-PAN LCD Panel

The Control Panel UMC100-PAN is an accessory for the UMC100 and can be used for monitoring, control and parameterisation of the UMC100. It can be directly plugged on the UMC100 or mounted separately on the panel door using the mounting kit.

Some of the main features are:

- fully graphic, multi-language user interface
- start and stop of the motor and acknowledgement of faults.
- display of measured values (e.g. motor current in A/% or start-up time) and status of inputs and outputs
- parameterisation
- parameter up - and download

The following diagram shows the UMC100-PAN with the monitoring and operating elements:

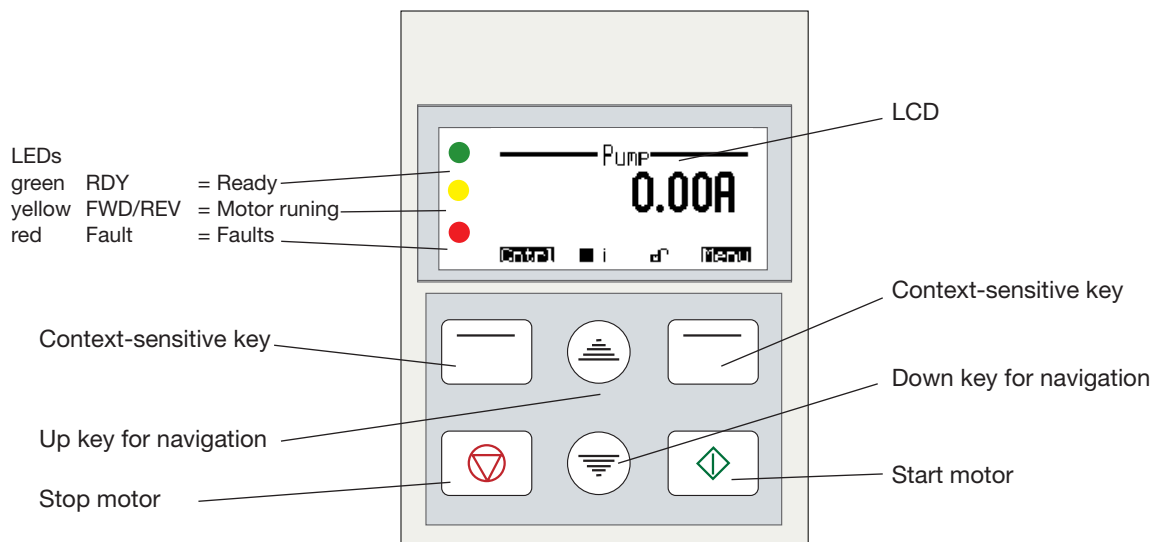

# Universal Motor Controller UMC100-FBP Technical Description

## 2 Installation

### Assembly and Disassembly of UMC100-FBP and IO Modules

You can attach the UMC100 and the IO modules as follows:

- Snap-on mounting onto a 35 mm standard mounting rail, without tools (UMC100 and IO devices)
- Mounting via screws on a mounting plate (UMC100 only)

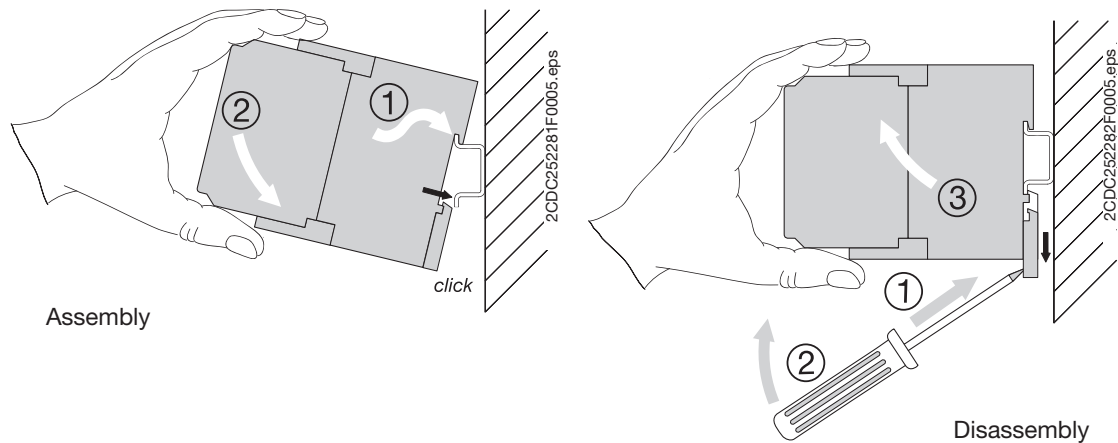

### Connecting the IO Modules DX111 and DX122

The modules DX111 and DX122 enable the number of and type of inputs and outputs provided by the UMC100 to be increased.

The UMC100 can be expanded with one digital IO module. Thus, 8 additional binary inputs, 4 additional relay outputs and 1 analogue output for driving an analogue indicator instrument are available.

The IO modules are connected via terminals Ca and Cb (see below) to the UMC100. Because of limited installation space it might be desirable to mount the IO modules separately from the UMC100. This can be carried out without any problems as long as the maximum cable length is not exceeded.

**The following limits apply when connecting an IO module:**

- Either the DX111 or DX122 can be connected. It is not possible to connect both of them to the UMC100.
- The distance between the UMC100 and the IO modules must not be longer than 3m.

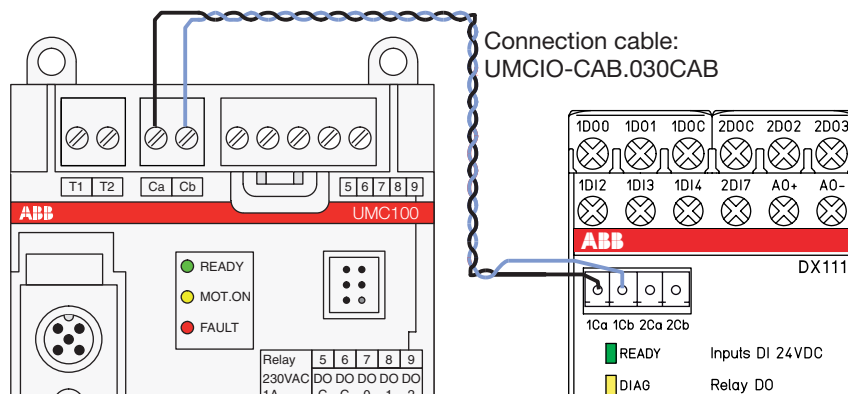

Wiring is shown for module DX111. It is the same for other modules.

# Universal Motor Controller

## UMC100-FBP

### Technical Description

#### Wiring DX1xx Inputs and Outputs

The diagram below shows the block diagram and wiring for both the DX111 and the DX122 modules. The digital inputs are galvanically isolated.

The common ground for the inputs 1DI0-4 must be connected to 1DIZ.

The common ground for the inputs 2DI5-7 must be connected to 2DIZ.

If no separate grounds are necessary, 1DIZ and 2DIZ can be connected to each other.

The relay outputs groups 1DO1/1DO2 and 2DO1/2DO2 have separate roots each.

The analogue output (AO+/AO-) is intended to drive an analogue instrument which can be used to display the motor current. It can be adjusted as a current or voltage output.

Open wire and short-circuit faults are detected.

Supported output levels are:

- 0/4 - 20 mA
- 0 - 10 mA
- 0 - 10 V

The output is scaled in a way that a motor current of 0% results in 0% at the output and a motor current of 200% results in 100% output level. The predefined scaling can be changed with the help of the custom application editor.

Example if the output is set as voltage output:

0% motor current ->  $U_{out}=0\text{ V}$ , 200% motor current ->  $U_{out} = 10\text{ V}$ .

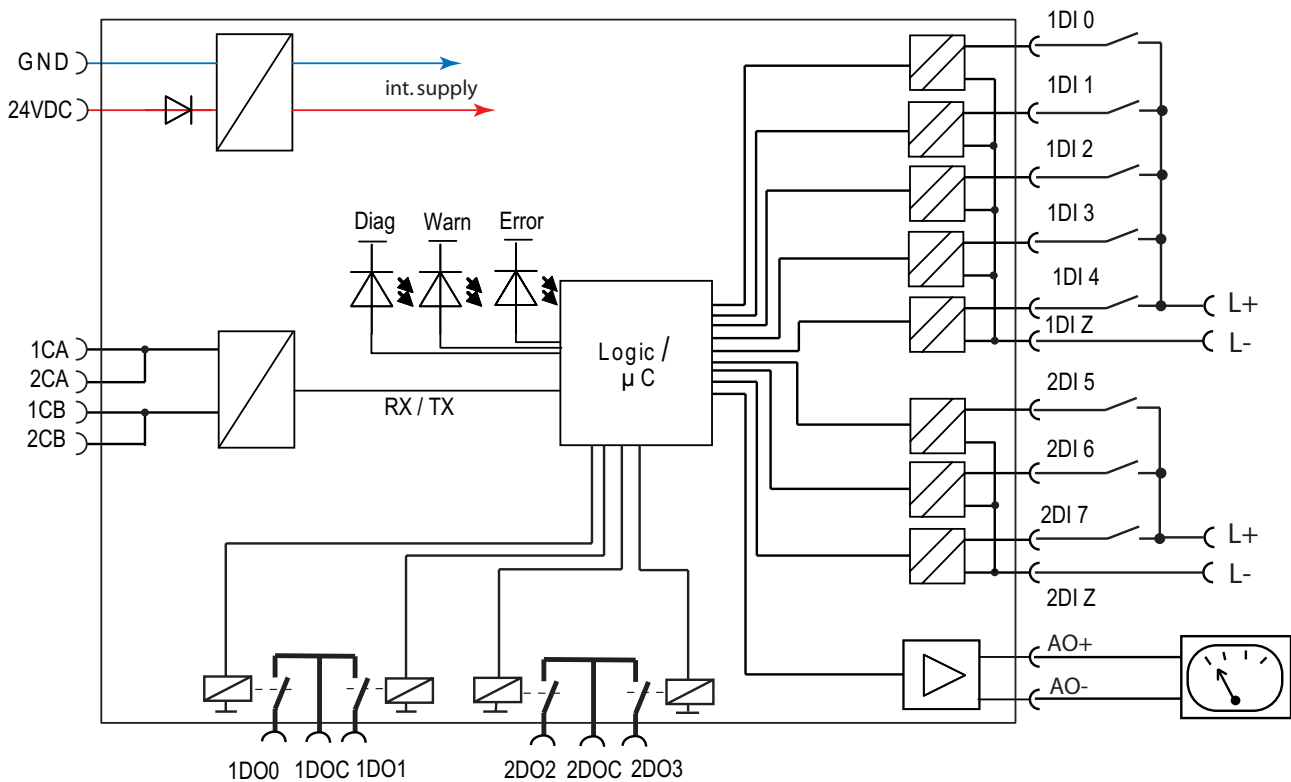

	L+	L-
DX111	+24VDC	GND
DX122	230VAC	N

▲ Wiring diagram of the DX111-FBP and DX122-FBP module.

# Universal Motor Controller

## UMC100-FBP

### Technical Description

#### Connecting the VI15x Voltage Module

The modules VI150 and VI155 allows to measure the motor supply voltage, cosphi (power factor) and to calculate thereof the active power and other values.



There are two module variants. The VI155 module can be used in grounded (TN) and ungrounded (IT) networks.

The VI150 module can only be used in grounded networks (TN).



When using a voltage module the phase order at the UMC must be L1 to L3 from left to right looking from top. See the image below.



Note that the connection cables for voltage measurement (terminals marked with L1, L2, L3) may require additional cable protection



Don't connect any cable to the VI1xx terminals marked with NC (not connected)



Note that a distance of 10mm left from the terminal L1 and right from the terminal L3 to the next device might be required for voltages >230VAC or > 400VAC respectively depending on the equipment mounted left and right of the module.

The module is connected via terminals Ca and Cb (see below) to the UMC100. It is possible to mount the module separately from the UMC100.

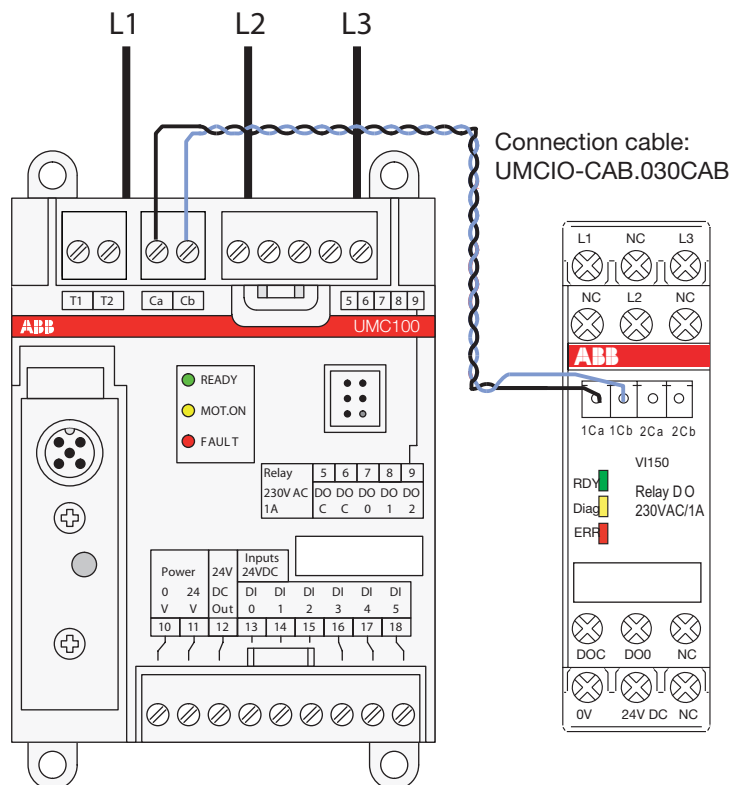

Wiring is shown for module VI150. It is the same for other modules.

# Universal Motor Controller

## UMC100-FBP

### Technical Description

#### Wiring VI15x Inputs and Outputs

The diagram below shows the block diagram and wiring of both the VI150 and the VI155 modules.

The relay output is a normally open contact and can be freely used.

The inputs L1, L2, L3 must be connected to corresponding supply phases.

The 0V of the VI150 supply must be connected to ground for proper measurement.

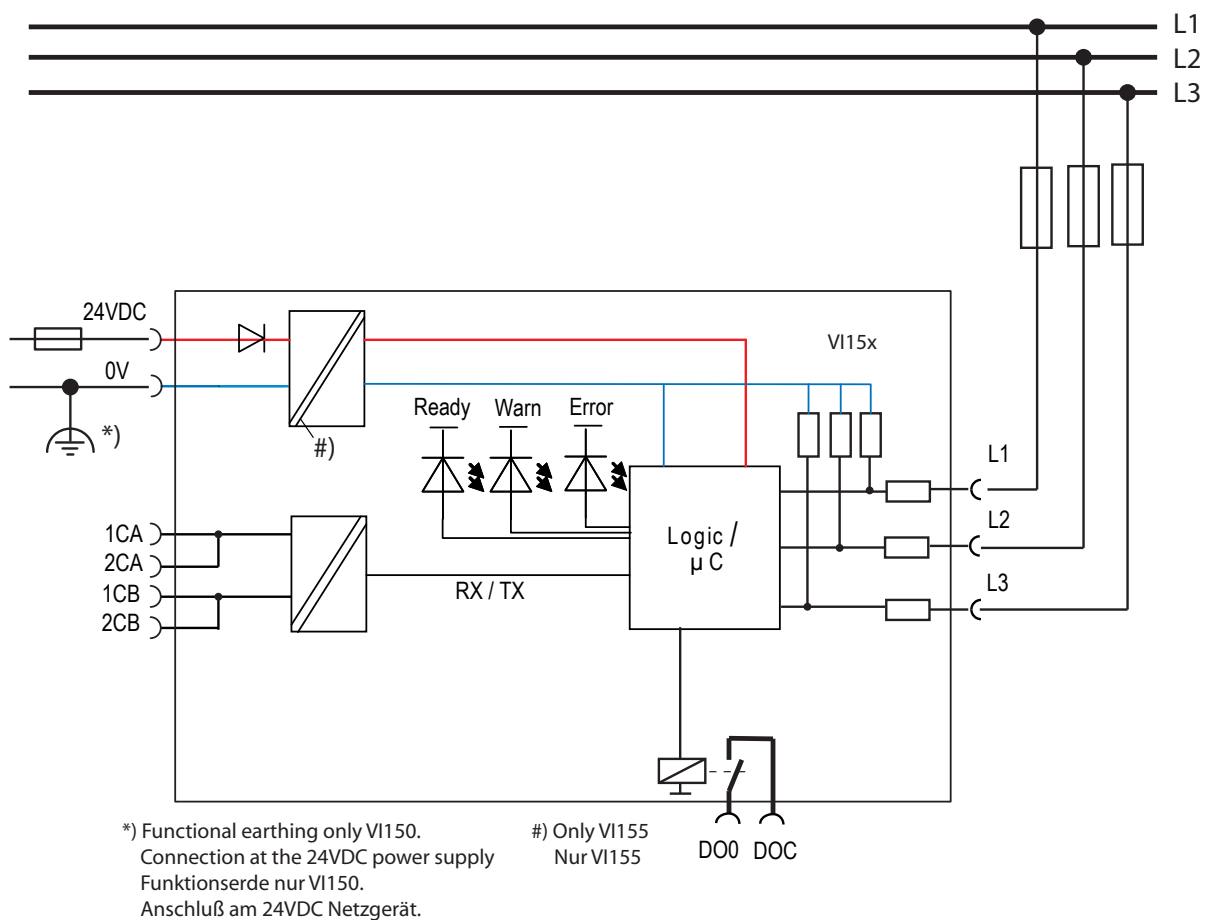

▲ Wiring diagram of the VI15x-FBP modules

#### Connecting the VI15x Voltage Module and a DX1xx IO Module

To connect both a VI15x and a DX1xx module to the UMC use the UMCIO-CAB cable to connect the first module with the UMC. And use the IOIO-CAB cable to connect the first module with the second module. The module order does not matter.

# Universal Motor Controller

## UMC100-FBP

### Technical Description

#### Connecting Contactors

Use spark suppression for larger contactors and also interface relays to maintain the service life of the UMC100 internal relays. For interfacing contactors with peak current > 0.5 A (Types A50 and larger) use an interface relay as shown below.

Actual ABB contactors - all currents for 230 V AC (Extract):

Contactor type	Inrush current [A]	Holding current [A]	Inrush power [VA]	Holding power [VA]	VDR for spark suppression (ABB type)	Service life of UMC100 relays [Switching cycle]
B6S-30-10-2.8 <sup>1)</sup>	0.01	0.01	2.4	2.4	-	500000
A9, A12, A16	0.30	0.03	70	8	RV5/250	500000 <sup>2)</sup>
A26, A30, A40	0.52	0.05	120	12	RV5/250	400000
A50, A63, A75 <sup>3), 5)</sup>	0.78	0.08	120	12	RV5/250	300000 <sup>2)</sup>
A95, A110 <sup>5)</sup>	1.52	0.10	350	22	RV5/250	use interface relay
A145, A185 <sup>5)</sup>	2.39	0.05	550	35	RC5-3/440	use interface relays
AF210, AF260, AF300 <sup>4)</sup>	2.04	0.04	470	10	-	500000
AF400, AF460, AF580, AF750 <sup>4)</sup>	3.7	0.05	890	12	-	500000

<sup>1)</sup> The contactor B6S-30-10-2.8 (24 V DC) is recommended as interface contactor due to its internal spark suppression.

<sup>2)</sup> All values only for contactors with spark suppression, see appropriate column. Use interface contactor if longer service life is required.

<sup>3)</sup> Interface contactor is recommended (e.g. B6S-30-10-2.8).

<sup>4)</sup> The contactors for higher currents are available with electronic interface only

<sup>5)</sup> Also available with electronic interface (AF50 to AF185).



Spark suppression is necessary for all types except the AF types to maintain a reasonable service life.

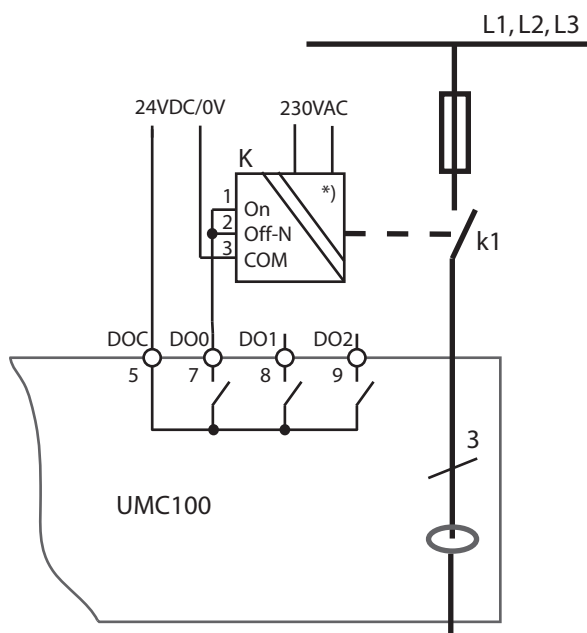

Connection of contactors with electronic interface (AF types) to the UMC100-FBP.

<sup>\*)</sup> Slide switch on the left side to position 'PLC' (up)

# Universal Motor Controller UMC100-FBP Technical Description

## Interfacing contactors with peak current > 0,5 A: Types A50 and larger

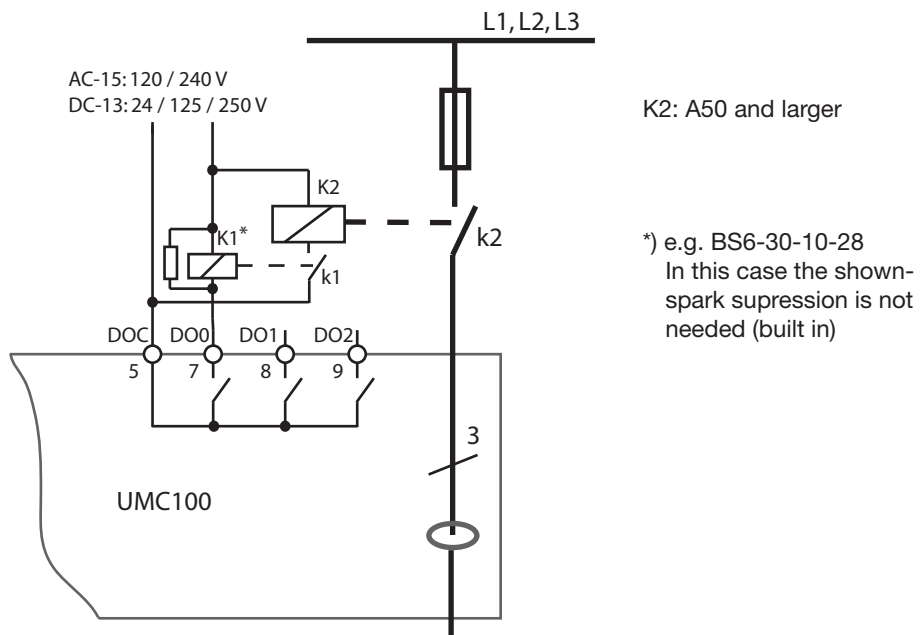

Connection of contactors with peak currents > 0.5 A (ABB types A50 and larger) to the UMC100-FBP.  
For checkback the auxiliary contact of the main contactor has to be used!

# Universal Motor Controller

## UMC100-FBP

### Technical Description

#### Motor Wiring

The following diagram shows different methods of connecting a motor. For perfect motor protection it is essential to set the correct nominal current  $I_p$ .

Example:

For inner delta wiring the parameter *Current Factor* can be changed to 1.73 to display the actual currents on the Control Panel and in the control system. The delta 3 circuitry is normally used for larger motors to reduce the current transformer size.

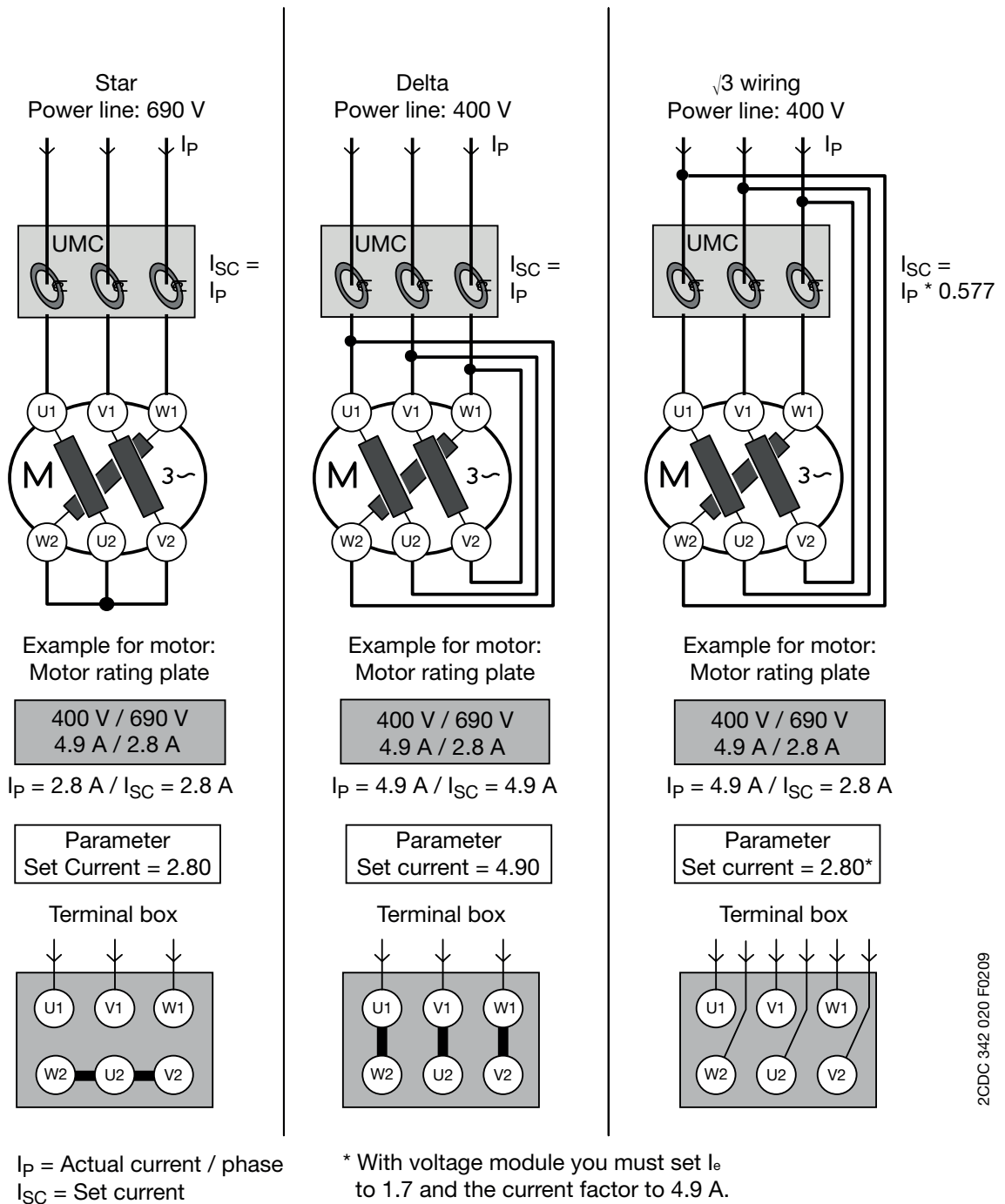

2CDC 342 020 F0209

Related Parameters:

- Nominal current  $I_{e1}$
- Nominal current  $I_{e2}$  (for two speed starters only)

# Universal Motor Controller

## UMC100-FBP

### Technical Description

#### Connecting External Current Transformers (CTs)

If the nominal motor current  $I_n$  is above 63 A an external current transformer (CT) must be used. The external CT transforms the primary current flow in a smaller secondary current according to the transmission ratio. This smaller current is then measured from the UMC100.

With the parameter *Current Factor* the current transformer transmission ratio can be configured. So the UMC100 knows the actually flowing primary current which is then used for the internal processing.

The current transformers CT4L/5L are available as accessories for the UMC100.



For the connection between CT and UMC use wires with a cross section of 2.5 mm<sup>2</sup> at a distance < 2 m. The burden of the CTs has to be below 60 mΩ.

If the supervision of the phase order is active or a voltage module should be used

- take care of the correct phase sequence and feed through direction of the main motor wires through the CT4L/5L
- take care of the correct phase sequence and feed through direction of the wires between CT4L/5L and UMC.

CT-type	Nominal current range of motor [A]	Max. current [A] (Accuracy 3%)	Current factor (Default = 1.0)	Secondary current at nominal primary current range [A]	Factor to be set in the UMC (e. g. via LCD panel)	Link kit <sup>1)</sup>
UMC100 CT built-in	0.24-63	630	1	-	100 (default)	-
CT4L185R/4	60-185	1480	46.2	1.3 - 4	4620	DT450/A185 -> AF145, AF185
CT4L310R/4	150-310	2480	77.5	1,94 - 4	7750	DT450/A300 -> AF210-AF300
CT5L500R/4	200-500	4000	125	1,6 - 4	12500	DT500AF460L-> AF400, AF460
CT5L850R/4	400-850	6800	212.5	1,88 - 4	21250	DT800AF750L -> AF580, AF750

<sup>1)</sup> Order data see catalogue

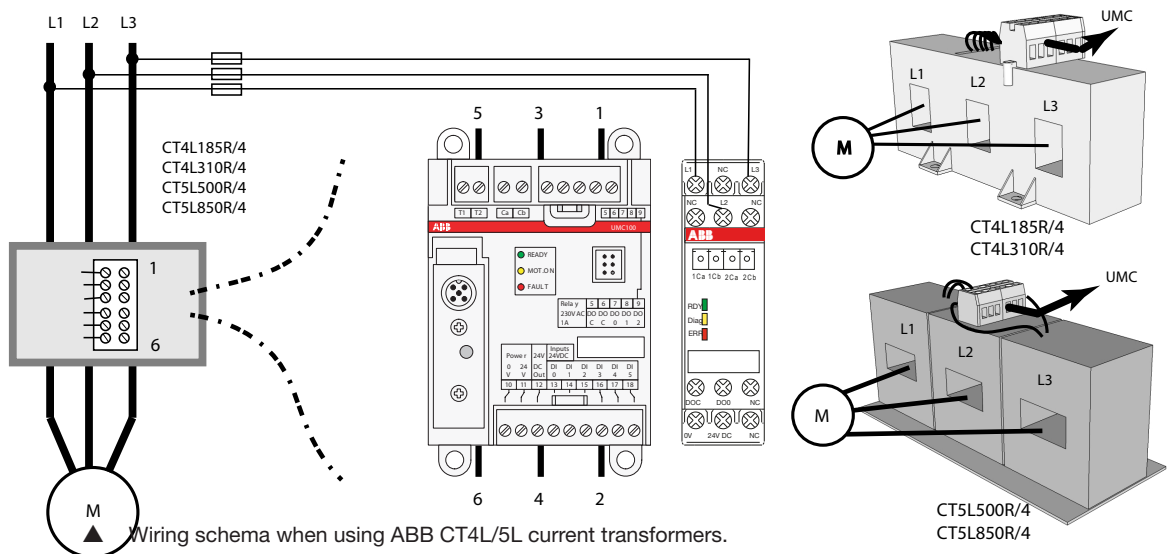

# Universal Motor Controller

## UMC100-FBP

### Technical Description



If current transformers of other suppliers are used the table above may serve as a calculation basis for the current factor.

Example: Type CT5L500R/4 means: Primary 500 A, secondary 4 A, current factor 125.

In the UMC to real motor current has to be set e. g. 500 A.



For high efficiency motors the start-up current can be  $> 8 * I_e$ .

In this case it might be necessary to use the next larger CT if the startup-current is above the max. current listed in the table above.

Examples:

$I_e = 180$  A, startup-current  $7 * I_e$  -> 1260 A -> Use CT4L185R/4

$I_e = 180$  A, startup-current  $10 * I_e$  -> 1800 A -> Use CT4L310R/4 in this case.

#### Operation Details for Motors with Small Set Currents



When using a UMC100-FBP in an environment with very strong magnetic fields and a small set current at the same time, the current measurement can deviate a few percent from the real current. Therefore the displayed motor current is too high and an overload trip occurs too early.

Very strong magnetic fields can originate from a contactor directly mounted beside the UMC100, closely passing current links or stray fields caused by large transformers.

When observing the effect, the distance between the UMC100 and the contactor shall be increased to about 5 cm or the UMC100 shall be rotated by 90 degrees or the motor wires shall be looped through the UMC100 two to five times.

When looping the motor wires multiple times, the parameter *Current Factor* must be adjusted according the number of loops. I.e. the parameter must be set to two if the wires are looped through the UMC100 two times. Two to five loops are supported. The displayed current and the current transmitted over the fieldbus are automatically corrected by the UMC100.

Please note that the adaptation of the current factor for  $\sqrt{3}$  circuits and multiple loops through the UMC100 are not possible at the same time.



Via fieldbus also higher values than five e. g. six can be set.

The UMC100 ignores such values and creates a parameter fault. Values above 100 are possible and used in combination with external current transformers (see previous page).

Related parameters:

- *Current Factor*
- *Nominal current 1 / 2*

---

# Universal Motor Controller

## UMC100-FBP

### Technical Description

---

#### Connecting the UMC100-PAN LCD Panel

The UMC100-PAN LCD panel can be used for the following purposes:

- Configuration of the UMC100-FBP
- Control of the motor and fault reset
- Monitoring of all IO signals, motor current and maintenance counters

The operator panel UMC100-PAN is mainly designed for mounting it on the front panel of a motor feeder or in a switchgear cabinet. A door mounting kit is provided for this purpose. With the mounting kit the degree of protection is IP54.

The UMC100-PAN can also be plugged directly on the UMC100 itself.

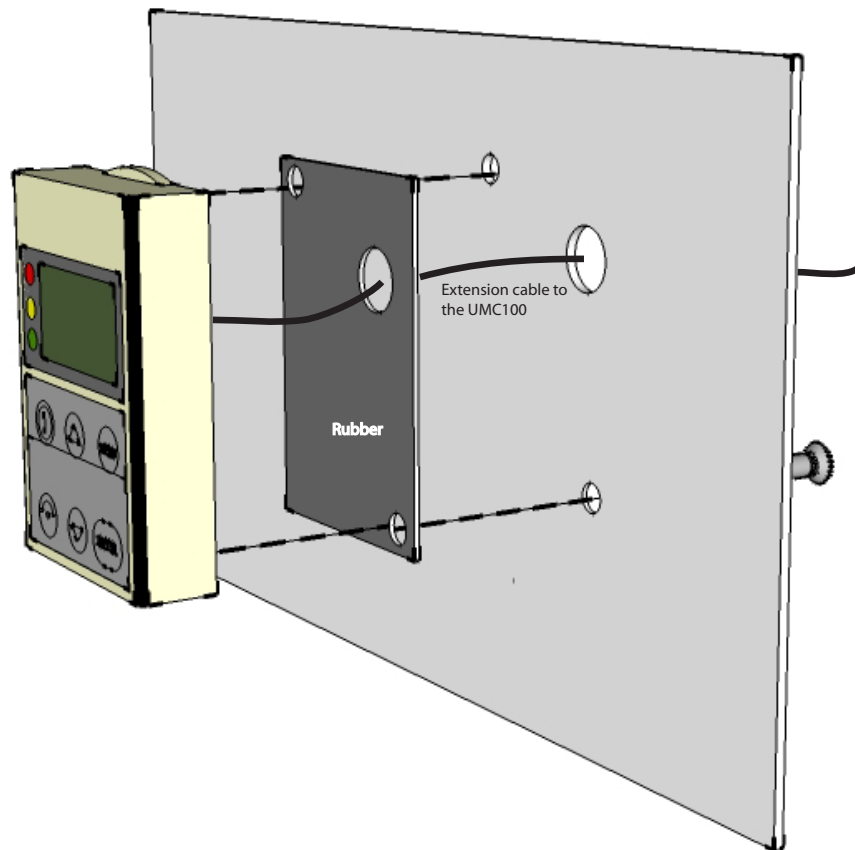

The UMC100-PAN is not compatible with the UMC22-PAN and cannot be used with the UMC22-FBP but only with UMC100-FBP.

# Universal Motor Controller

## UMC100-FBP

### Technical Description

#### Using the UMC100 in a PROFIBUS DP Network

PROFIBUS DP is at present one of the most common fieldbus for industrial applications worldwide and is standardised in IEC61158 together with other fieldbus protocols. The PROFIBUS DP standard has defined different network topologies. The most commonly used one is the 'daisy chain' topology where one device is connected after the other.

PROFIBUS DP has evolved over time. The first services offered by PROFIBUS DP are the so-called V0 services. They define block parameterisation, configuration, cyclic data exchange and diagnosis information exchange. DP-V0 only allows the complete parameter set to be written in one block. The bus master sends the parameter block to the slave during powering up of the slave/device. Some control systems also allow the sending the parameter block during normal operation.

Later the PROFIBUS DP-V1 specification introduced new acyclic read/write services within the context of the PROFIBUS DP-V1 expansions. These acyclic services are inserted into special telegrams during ongoing cyclical bus operation and thus ensure compatibility between PROFIBUS DP-V0 and PROFIBUS DP-V1.

To integrate the UMC100-FBP into a PROFIBUS network either the PDQ22-FBP or the PDP22-FBP FieldBusPlugs can be used. PDQ22-FBP allows to connect up to four UMC100s via one bus node. PDP22-FBP integrates one UMC100 only (i.e. one bus address per UMC100).

The diagram below shows the sketch of a PROFIBUS bus line with UMC100s integrated via PDP22 and PDQ22. A detailed description about the creation of PROFIBUS lines using PDP22 and PDQ22 is available in the FieldBusPlug manuals.

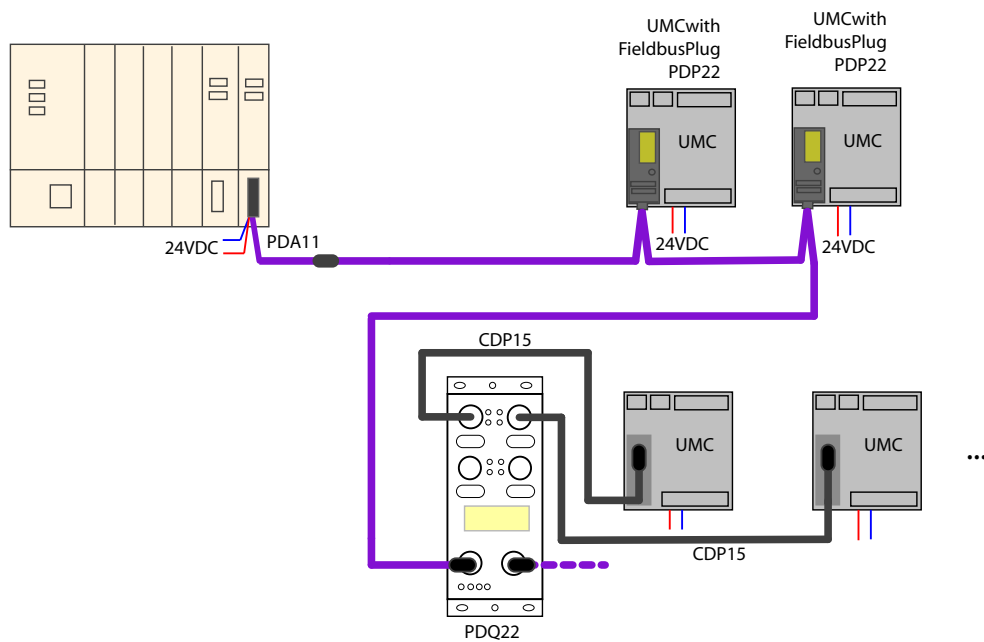

- ▲ PROFIBUS Line with PDP22 and PDQ22. Wires in purple are PROFIBUS cables. Wires in black (CDP15) are standard extension cables to connect PDQ and UMC100.

# Universal Motor Controller

## UMC100-FBP

### Technical Description

#### Integration with the GSD File

Besides the physical connection of a device to a PROFIBUS line, the engineering of the whole PROFIBUS system in the PROFIBUS master is necessary. Every modern PLC (Programmable Logic Controller) or DCS (Distributed Control System), that can be used as PROFIBUS master, offer the possibility to configure and parameterise devices connected to the master.

Electronic data sheets are used as a basis. In the PROFIBUS world these electronic data sheets are called GSD files. Within such a file all properties relevant for operation of the slave are described (e.g. supported baud rates, max. number of modules etc.).

The GSD file ABB\_0A09.GSD (for PDQ22) and ABB\_34E0.GSD (for PDP22) are contained in the software Engineering Package

PBE91-FBP.010x 1SAJ924091R010x.ZIP

The ZIP file can be obtained from ABB's web site (<http://www.abb.de> -> Control Products and Systems) or on the FBP System CD (2CDC 190 008 E04xx). Please ask your local sales office for it.



The UMC100 can be parameterised using the GSD file. But due to parameter length limitations only the most important parameters can be configured with the GSD file in the event that the PDQ22 is used. For PDP22 this limitation does not exist.

#### Integration with the Device Type Manager (DTM)

In addition to the option of integrating devices with GSD files more and more modern control systems support the FDT/DTM concept. FDT (Field Device Tool) technology standardises the communication interface between field devices and systems.

For the UMC100 (and also other FBP devices) a DTM is available which can be ordered separately. Consult the PBDTM manual for more information.



For creating a customer-specific application the DTM must be used! Parameterisation of the control and protection parameters can also be carried out with the GSD file only.

#### Using the UMC100 in a DeviceNet Network

DeviceNet is based on the Controller Area Network (CAN) technology and mostly used in the Americas. To integrate the UMC100 into a DeviceNet network use the DNP21-FBP FieldBusPlug. The figure below shows the sketch of a DeviceNet line with DNP21-FBP, two UMC100s and available accessories. More details are available in the technical manual of the DNP21-FBP.

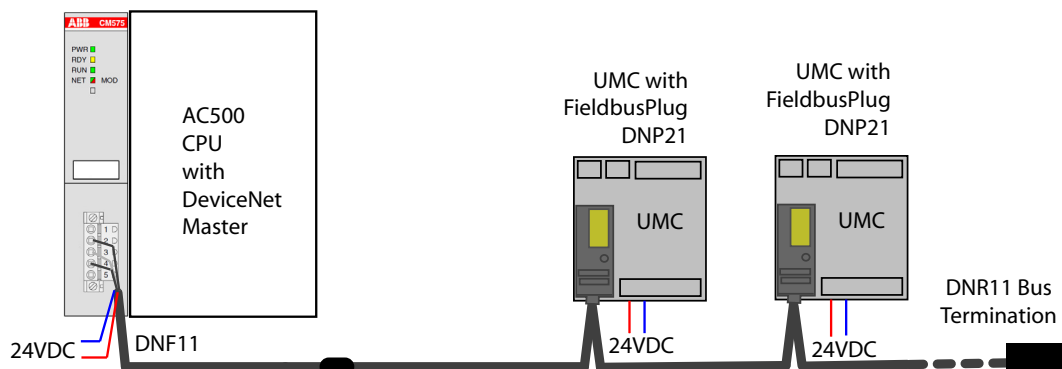

# Universal Motor Controller

## UMC100-FBP

### Technical Description

#### Integration with the EDS File

Besides the physical connection of a device to a DeviceNet line, the integration and engineering of the devices in the DeviceNet master is necessary.

An electronic data sheet is provided for the UMC100 for that purpose. In the DeviceNet world these electronic data sheets are called EDS files. Within these files all the properties relevant for operating the slave are described (e.g. supported baud rates, parameters, ...).



Configuration of the control and protection parameters of the UMC100 can be carried out using the EDS file. For creating a customer-specific application the DTM with UTF21 communication adapter can be used!

The CANopen fieldbus also uses EDS files. But these are different from the DeviceNet ones. In case of problems make sure you use the correct file!

The EDS file ABB\_UMC100.eds is contained in the Software Engineering Package

DNE91-FBP.010x 1SAJ923091R010x.zip

The ZIP file can be obtained from ABB's web site (<http://www.abb.de/stotz-kontakt>) or on the FBP System CD (2CDC 190 008 E04xx). Please ask your local sales office for it.

#### Using the UMC100 in a CANopen Network

CANopen is based on the Controller Area Network (CAN) technology and often used within large machines or vehicles. To integrate UMC100 into a CANopen network use the COP21-FBP FieldBusPlug. The figure below shows the sketch of a CANopen line with two COP21-FBP, two UMC100s and available accessories. More details are available in the technical manual of COP21-FBP.

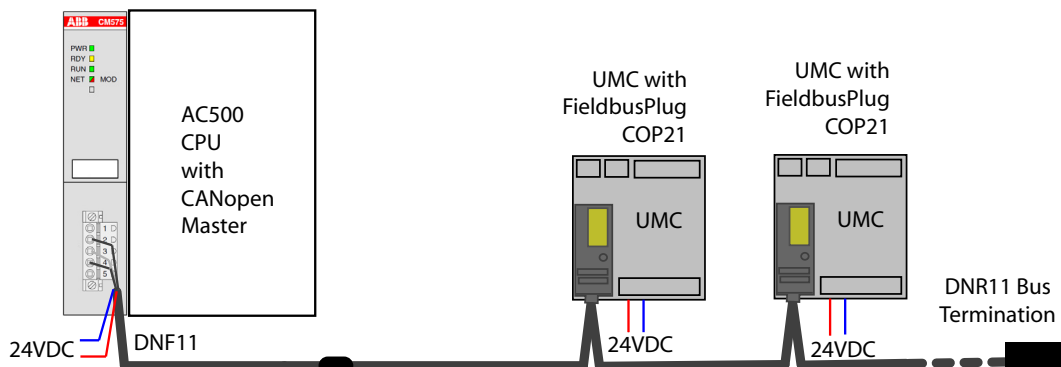

- ▲ CANopen Line with COP21 and UMC100. Please note that the accessories of CANopen and DeviceNet are the same. Do not be confused by the fact that the DNF and DNR have a 'DN' in their names.

#### Integration with the EDS File

Besides the physical connection of a device to a CANopen line, the integration and engineering of the devices in the CANopen master is necessary. For that purpose an electronic data sheet is provided by ABB. In the CANopen world these electronic data sheets are called EDS files. Within these files all the properties relevant for operating the slave are described (e.g. supported baud rates, parameters, ...).



Configuration of the control and protection parameters of the UMC100 can be carried out using the EDS file. For creating a customer-specific application the DTM with UTF21 communication adapter can be used!

The DeviceNet fieldbus also uses EDS files. But these are different from the CANopen ones. In case of problems make sure you use the correct files!

The EDS file FBP\_CO\_UMC100.eds are contained in the Software Engineering Package

COE91-FBP.010x 1SAJ923092R010x.zip

The ZIP file can be obtained from ABB's web site (<http://www.abb.de/stotz-kontakt>) or on the FBP System CD (2CDC 190 008 E04xx). Please ask your local sales office for it.

# Universal Motor Controller

## UMC100-FBP

### Technical Description

#### Using the UMC100 in a MODBUS RTU Network

The MODICON Modbus® RTU protocol is a widely used network protocol based on the RS485 physical layer. It is provided in many PLCs that do not offer any other fieldbus. To integrate the UMC100 into a Modbus network, use the MRP21-FBP FieldBusPlug.

The diagram below shows the sketch of a Modbus line with two MRP21-FBP, two UMC100s and available accessories. More details are available in the technical manual of MRP21-FBP.

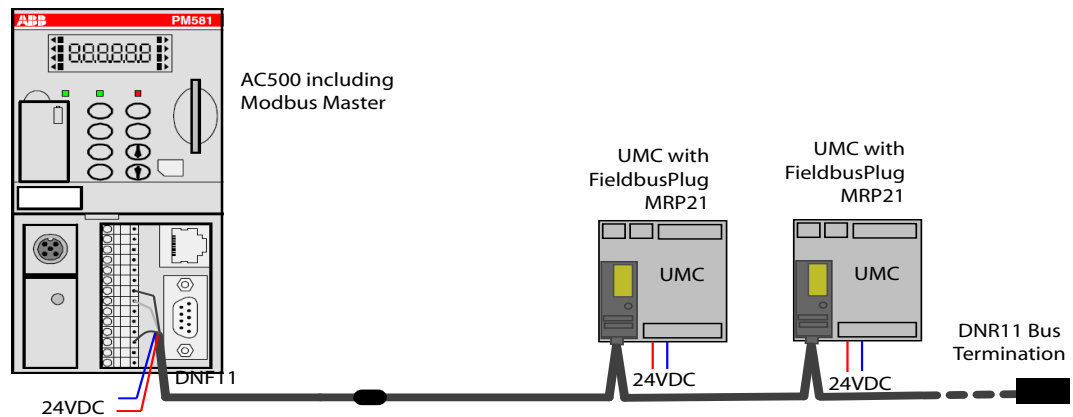

- ▲ Modbus Line with MRP21 and UMC100. Please note that the accessories of CANopen and DeviceNet are the same. Do not be confused by the fact that the DNF and DNR have a 'DN' in their names.



There are no device description files defined by the Modbus standard. Therefore we recommend that you parameterize the UMC100 either using the UMC100-PAN or using a laptop with the UTF21-FBP communication adapter.

# Universal Motor Controller

## UMC100-FBP

### Technical Description

#### Usage in Draw-Out Systems

The withdrawable technique is often used in industries where the highest availability and shortest down-times are required. In the event of an error in a drawer, the replacement with a spare drawer shall be made as fast as possible. UMC100 has several unique features supporting its use in drawer systems:

- The separation of FieldBusPlug (bus node) and UMC100

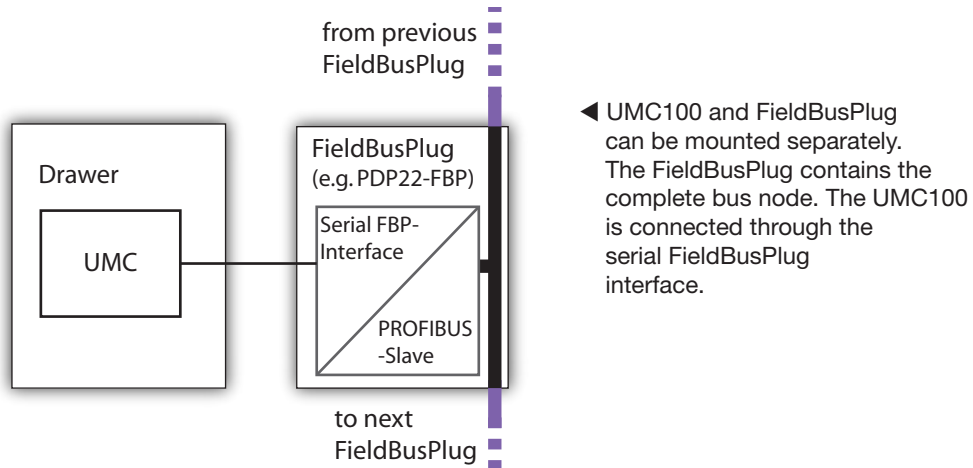

- In draw-out installations the UMC100 is usually mounted inside the drawer whereas the FieldBusPlug is mounted in the cable chamber. This ensures that no trunks are required but a straight bus line can be implemented. A very stable bus communication even at high baud rates is the result!
- In the event of a drawer replacement the FieldBusPlug stays active and sends a diagnosis message to the control system that the UMC100 is missing. Even more important - the fieldbus address is stored in the FieldBusPlug. If a new UMC100 is connected the old bus address is automatically used. There is no need for setting a new address! See parameter *Address Check* for additional details.

All necessary auxiliaries required for the installation are available. See the diagram below on how to use a PDP22, MRP21, DNP21 or COP21 in a drawer system. The example shows PDP22 for PROFIBUS.

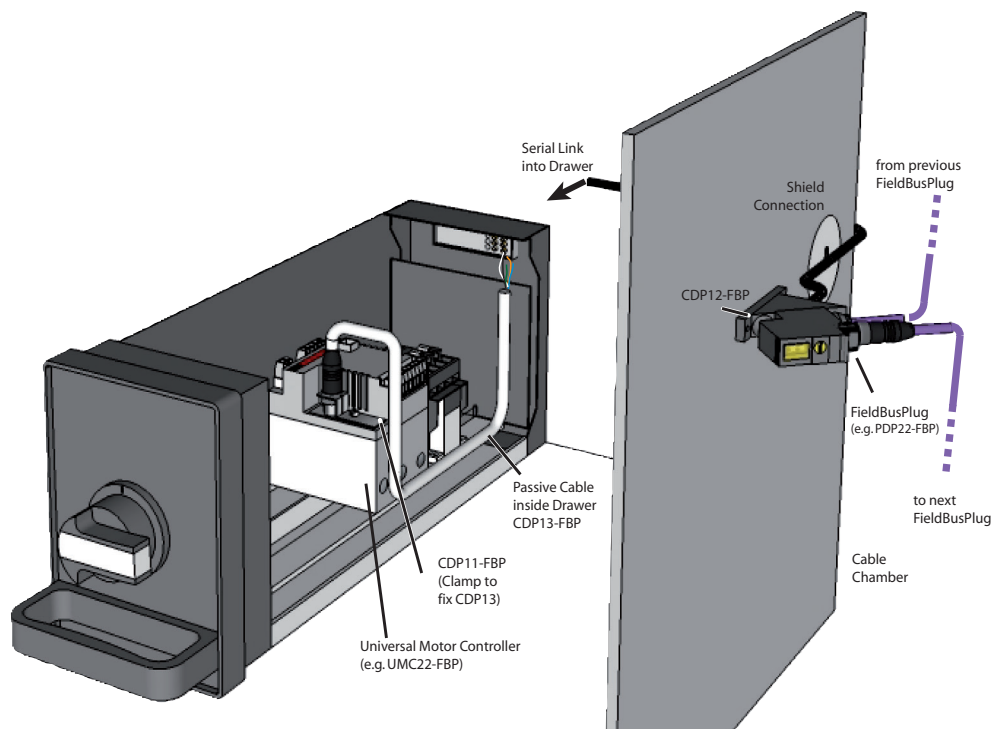

- ▲ FieldBusPlug and accessories in a draw-out installation. The fieldbus node is outside the drawer so no drops are required.

---

# Universal Motor Controller

## UMC100-FBP

### Technical Description

---

The following diagram shows the usage of the PDQ22 in a drawer system with the available accessories.

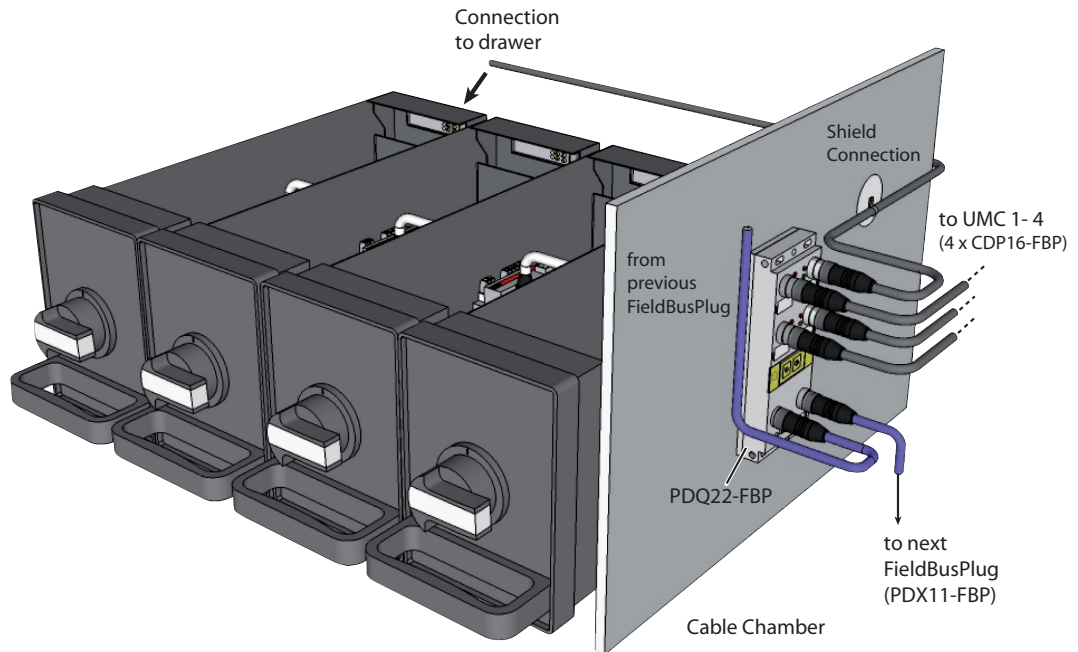

- ▲ Using PDQ22-FBP in a withdrawable installation allows the connection of up to four UMC100s. The PROFIBUS node is mounted outside the drawers.

---

# Universal Motor Controller

## UMC100-FBP

### Technical Description

---

### 3 Commissioning

This chapter provides an overview of the required commissioning steps. For details about the single steps please consult the related chapters.

#### Commissioning Steps

To commission the UMC100-FBP, proceed as follows:

##### A) Wiring

Wiring and 24 V DC / 0 V connection:

Hard wire with switch apparatus and other components acc. to the application requirements.

Connection of contactors: Use spark suppression, for larger contactors also interface relays to maintain a good service life of the UMC100 internal relays.

Motor wiring: Check the wiring of the motor to ensure correct setting of  $I_e$  for perfect motor protection. When using UMC100 with motors of nominal currents  $< 1$  A please read section "Operation Details for Motors with Small Set Currents". If the nominal motor current is above 63 A read section "Connecting External Current Transformers (CTs)" on how to use the UMC100 with external current transformers.

If an IO expansion module is used connect the UMC100 with the IO module and hard wire the inputs of the expansion module acc. to the application requirements.

##### B) Switching on the power supply

Switch on the supply voltage of the UMC100. If connected with a FieldBusPlug also ensure that the FieldBusPlug is powered. In the fault-free state, the green UMC100 LEDs should light up.

LEDs on the UMC100:

Green (ready)	On
Yellow (motor running)	Off
Red (fault/trip)	Off

LEDs on the FieldBusPlug:

In fault free state H1/H3 (left upper and lower LEDs) should light up. If no cyclic bus master is active H2 (upper right LED) is flashing. See the technical description of the FieldBusPlug in use.

Continue with Step C) if fieldbus communication is required or continue with step D) to start the configuration. In case of an error use the LED/UMC100-PAN information of the UMC100/FieldBusPlug to find out the cause of the fault (see section "Fault Handling").

##### C) Setting the fieldbus node address

Before connecting the UMC100 to a fieldbus network (e.g. PROFIBUS) set the fieldbus address using UMC100-PAN. That means the slave address is directly adjusted and stored in the UMC100.

To change the bus address, press *Menu*, select *Communication* and then *Bus Address*.

Adjust the address within the limits defined by the fieldbus type (for PROFIBUS e.g. 2 to 125).

##### D) Start configuring the UMC100 via LCD panel, laptop or control system

The following parameters need to be adjusted

- Motor management related parameters e.g. the control function (see section "Configuring the Motor Management Functions")
- Parameters defining how to start and stop the motor from the different control places (see section "Configuring the Motor Management Functions -> Starting and Stopping the Motor").
- Parameters related to the motor and its protection functions (see section "Configuring the Motor Protection Functions").
- Parameters related to the fieldbus communication interface (see section "Configuring the Fieldbus Communication")
- Other settings such as the panel language or the usage of a connected DX1xx module.

---

# Universal Motor Controller

## UMC100-FBP

### Technical Description

---

#### Select the Required Configuration Mode for the UMC100-FBP

The UMC100 can be configured in different ways depending on your system setup:

#### Configuration via LCD panel

The device address has to be configured via LCD panel. And it is possible to adjust the other protection and control parameters of the UMC100 using the panel. The configuration via LCD panel is good for stand-alone applications (without bus) and when no Laptop for parameterisation is in use. The configuration via LCD panel can be password-protected to prevent unintentional parameter changes.

#### Configuration from within the control system

Device description files allow the integration and configuration of a device in the fieldbus master. For PROFIBUS this file is called a GSD file. In case of CANopen and DeviceNet so-called EDS files are commonly used. The UMC100 can be configured using these configuration files. A considerable benefit of this method of configuration is that the configuration is stored centrally in the control system and can be downloaded again in the event of a replacement.

If the UMC100 is connected via PROFIBUS and the control system supports the FDT/DTM technology it is also possible to configure the UMC100 using the PBDTM (PROFIBUS Device Type Manager) from within the system. The PBDTM offers a very user-friendly configuration interface which also allows to adapt the internal UMC100 application logic using the custom application editor. In online mode the PBDTM additionally provides access to all diagnosis, service and process data.

#### Configuration via Laptop

The configuration via laptop option is a convenient way to parameterise and monitor the UMC100. The FDT/DTM based configuration tool provides full access to all data available in the UMC100. The following functions are available:

- Online and offline configuration and parameterisation of the UMC100
- Monitoring and diagnosis of the UMC100 during operation
- Function block based programming of a user specific application
- Utilising of user roles and optional password protection for different tasks (e.g. engineering or operation)

The UTF21 communication adapter provides a point-to-point connection between a single UMC100 and your laptop. The top half of the following diagram shows this setup.

If several UMC100s are connected via PROFIBUS the UTP22 communication adapter can be used. This adapter connects your laptop to the PROFIBUS line and allows central configuration and monitoring of all UMC100s connected to this line. This is recommended for larger PROFIBUS installations.

For configuration via laptop use the ABB tool "Asset Vision Basic". It is jointly used by ABB Instrumentation and ABB Control Products. It is based on the FDT/DTM standard.

The installation and use of the PBDTM is described in the PBDTM manual. It also provides general information about the FDT/DTM technology.

Please read this manual carefully if you are unfamiliar with the FDM/DTM technology.

# Universal Motor Controller

## UMC100-FBP

### Technical Description

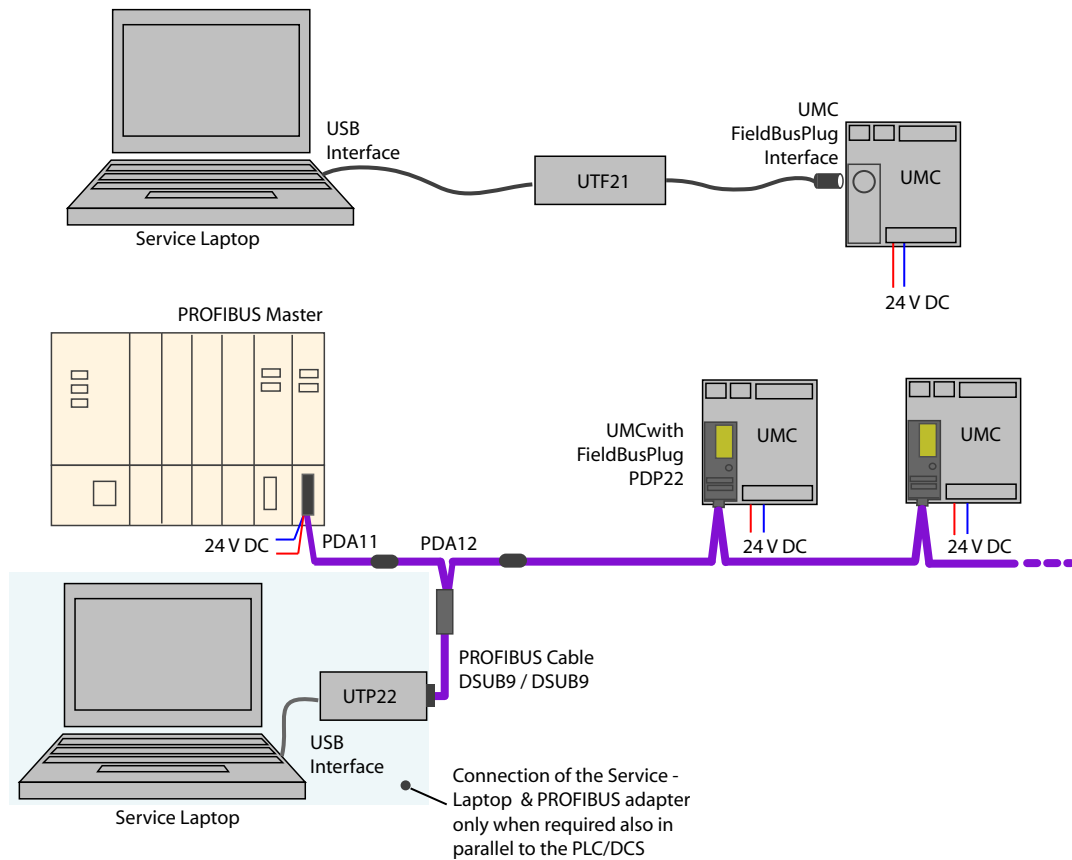

- ▲ Connection of a service laptop using UTF21-FBP (point-to-point) or UTP22-FBP (for a whole PROFIBUS line)

#### Test Position

It is possible to configure a multifunction input (DI0, DI1 or DI2) to inform the UMC that the feeder is in test position. If the input signals test position the feeder's main circuit must be isolated from the motor supply but the control voltage of the UMC must be connected.

During active test position the function of the feeder and its integration into the control system can be tested. I.e. the motor can be started but the UMC does not trip because of a missing checkback.

Use the parameters Multifunction 0,1,2 to enable this function.



If the feeder is in test position the UMC has disabled the checkback supervision and other motor current related protection functions. Therefore the test position must be only active for commissioning purposes.

---

**Universal Motor Controller  
UMC100-FBP  
Technical Description**

---

# Universal Motor Controller

## UMC100-FBP

### Technical Description

## 4 Configuring the Motor Protection Functions

### General Information

The UMC provides comprehensive motor protection including phase failure detection, adjustable motor protection for stalled motors during startup or normal operation, configurable current limits to generate trips or warnings and many more.

The different protection and monitoring functions generates either warning signals, trip signals and measured or calculated process values. All these data are available to the user to either display them on the LCD panel, transfer them to the control system or process them in a custom specific applicaion.

The UMC100 can be used with or without an additional voltage module. The protection functions available without a voltage module are described in section "Thermal and Current Motor Protection Functions". The protection functions that require a voltage module are described in section "Voltage and Power Protection Functions". Finally the voltage Dip function which can be used with or without a voltage module is described in section "Voltage Dips, Load Shedding".

### Automatic Reset of Protection Faults

The setting of the "*Fault autoreset*" parameter determines how the UMC manages protection trips.

- *Off* (the default setting): A protection trip must be acknowledged from the user. This can be done via LCD panel, fieldbus or the multifunction inputs DI0-DI2 if configured.
- *On*: A protection trip is automatically acknowledged without intervention of a human operator if the trip condition has gone (e.g. cooling time over).

### EOL and Current based Protection Functions

In this section you find information on how to configure the different motor current based protection functions of the UMC.

The following topics are covered:

Function and parameters of the electronic overload protection, the thermal memory and points to consider if the motor is started cyclically (e.g. S3 motor operation mode)

- Long start, locked rotor protection during motor start
- Overcurrent and undercurrent protection during normal operation
- Imbalance protection
- Phase loss protection
- Phase sequence
- Thermistor motor protection
- Earth fault protection with auxiliary device CEM11-FBP or internally calculated

The following process values are available:

Process Value	Explanation	Data range
Motor Current	The average current in the three phases	0...800 % of $I_e$
Earth Fault Current	Calculated earth fault current	% of $I_e$
Thermal Load	Thermal load of the motor	0...100%. 100% is the trip level.
Current Imbalance	Imbalance of the motor current in the three phases	0...100%
Time to Trip	Time until the EOL trips the motor	0 ... 6553s (6553s maens an infinite trip time)
Time to Cool	Time until the motor can be restarted	0 ... 6553s
PTC Resistance	Value measured from the PTC input in ohms.	0 ... 4800 Ohm
Line Frequency	Mains frequency	45 ... 65 Hz

# Universal Motor Controller

## UMC100-FBP

### Technical Description

Protection functions can be either on or off. If switched on, they can trigger a protection trip or a warning (excluding the thermal overload which is always active and triggers a trip). For some functions an optional delay can be specified. Some protection functions are only active after motor start-up while others are active during motor start.

Below is an overview of the available protection functions and when they are active. For details see the following sections.

Protection Function	When active	Available Options: Warning/Trip/Off	Automatic Fault Reset Possible
Electronic Overload	Always	Trip	Yes
Electronic Overload Prewarning	Always	Warning	-
Locked Rotor	During motor start	Trip	-
High Current	After motor start	Separate warning and trip levels /Off. Optional delay.	-
Low Current	After motor start	Separate warning and trip levels / Off. Optional delay.	-
Imbalance	Always (Motor current > 25% of $I_e$ and all three phases available)	Separate warning and trip levels / Off. Optional delay.	Yes
Phase Loss Protection	Always (Motor current > 25% of $I_e$ )	Trip, Off	-
PTC Protection	Always	Trip, Warning, Off	Yes (excluding PTC wire break and short circuit)
Earth Fault Protection	Always After start-up	Trip, Warning, Off	-
Load Shedding / Volt- age Dip	Always Not in testposition	See subsection voltage Dip	-



The motor start-up period ends when the motor current drops to 135% of  $I_e$  or if the class time (i.e. Class 5 -> 1.5 s, Class 10 -> 3 s, class 20 -> 6s, class 30 -> 9s, class 40 -> 12s) is over. The class time begins with the start command.

The motor-related and protection-related parameters shall be set according to the motor manufacturer's data sheet. Other parameters of the UMC shall be carefully selected based on the process and the system requirements.

# Universal Motor Controller

## UMC100-FBP

### Technical Description

#### Electronic Overload Protection

The UMC protects three-phase AC motors in compliance with IEC 60947-4-1. The tripping class can be set to class 5, 10, 20, 30 or 40. The advanced thermal motor model considers both the copper and iron parts of the motor thus providing the best protection of the motor.

Before an electronic overload trip actually happens, a pre-warning can be generated. During high overload situations the prewarning might be raised just a few seconds before the actual trip happens.

The presently used thermal capacity (0...100%) of the motor is available to the user and thus a prediction of the time to trip for the current load situation. If the motor is switched off the time to trip shows 6553 sec (never trips). If the motor is running the predicted trip time is updated regularly. The smaller the value the earlier the trip happens.

After an overload trip, the remaining cooling down time (=time to restart) is calculated regularly and also available to the user. The motor can be restarted if the cooling time is 0 sec.

#### Block Diagram:

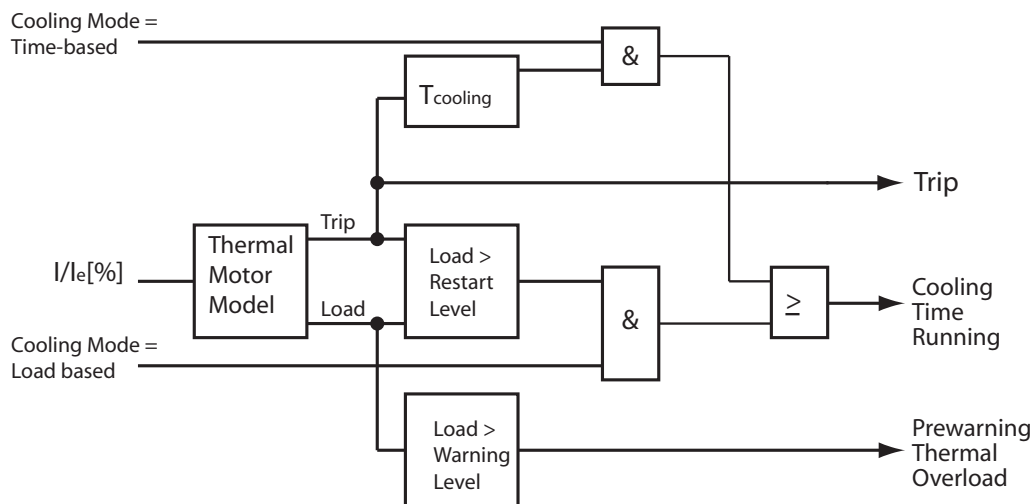

▲ Signal flow of the thermal overload protection

The thermal information of the motor is cyclically stored (thermal memory) <sup>1)</sup>.

After a thermal overload trip the motor must cool down before it can be started again. There are two options to define the necessary duration of the cooling time.

- Fixed cooling time: The user has to specify a fixed duration e.g. 15 minutes. After a thermal overload trip a further motor start is inhibited for that time. The time that has to be adjusted depends on: Motor size, motor with or without ventilation, the environment temperature etc. Considering these points the appropriate cooling time can be estimated. Some examples of motor cooling time constants (t.c.) (motor standstill) can help:

Size	1 kW - 1 pole	5 kW - 1 pole	5 kW - 2 pole	20 kW - 2	20 kW - 3	100 kW - 3
c.t.	10 min	15 min	20 min	30 min	40 min	70 min

- Thermal capacity based cooling: The user specifies to which level (e.g. 60%) the thermal load level must drop before a motor start is possible again.

<sup>1)</sup> If the UMC was switched off while the cooling time was running and the power down time was shorter than 20 min, the UMC restarts the cooling timer with the remaining cooling time. Otherwise the cooling time is set to zero.

# Universal Motor Controller

## UMC100-FBP

### Technical Description

#### Example of trip class selection:

Select the trip class so that the motor is thermally protected, even when the rotor is stalled.

This means that the tripping curve of a cold motor has to be below the coordination point  $I_a/I_e$  and  $t_E$  whereas  $I_a$  is the actual current,  $I_e$  is the nominal current of the motor and  $t_E$  is the maximal heating time as defined by the motor manufacturer.

Example: Motor with enhanced safety has the data:

- Power = 7.5 kW
- Relation  $I_a/I_e = 7.4$
- Heating time  $t_E = 11$  s

The following diagram shows the tripping time for cold motors at 3-pole symmetric load:

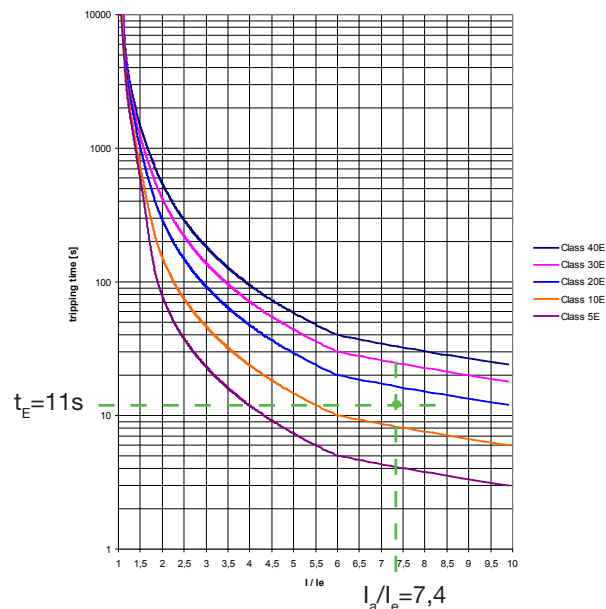

▲ Example for the trip class selection for a given motor

The trip classes 5 and 10 are allowed because the appropriate times (3 s, 7 s) are below the time  $t_E$  of the motor (including the tolerance 10% of the UMC).

# Universal Motor Controller

## UMC100-FBP

### Technical Description

#### Cyclic motor operation modes

Some applications require periodic start/operation/stop cycles. Setting up such applications requires care when selecting the cooling down times or defining the shortest possible start period.

In the next diagram three successive start cycles are displayed. In each cycle the motor starts at 700%  $I_e$ . This high load lasts for about 7 seconds. Then the current goes back to  $I_e$  within 6 seconds and stays at 100%  $I_e$  for about 180 seconds. At T1 the motor is switched off and cools down for 200 seconds (cooling time is set to 200s).

After the cooling time is over the next start takes place at T2. During this cycle the motor also cools down for 200s but the calculated thermal motor load  $q$  is already above 40%. The third start at T4 leads - as expected - to a thermal overload trip



For cyclic operation modes it is important to keep the cycles long enough to allow the motor to cool down sufficiently.

For cyclic start patterns it is better to select the cooling mode option "Restart Level" which allows a restart based on the thermal load level. In the case shown below the third start would then be allowed at the earliest at T5 for the given  $\theta_R$ .

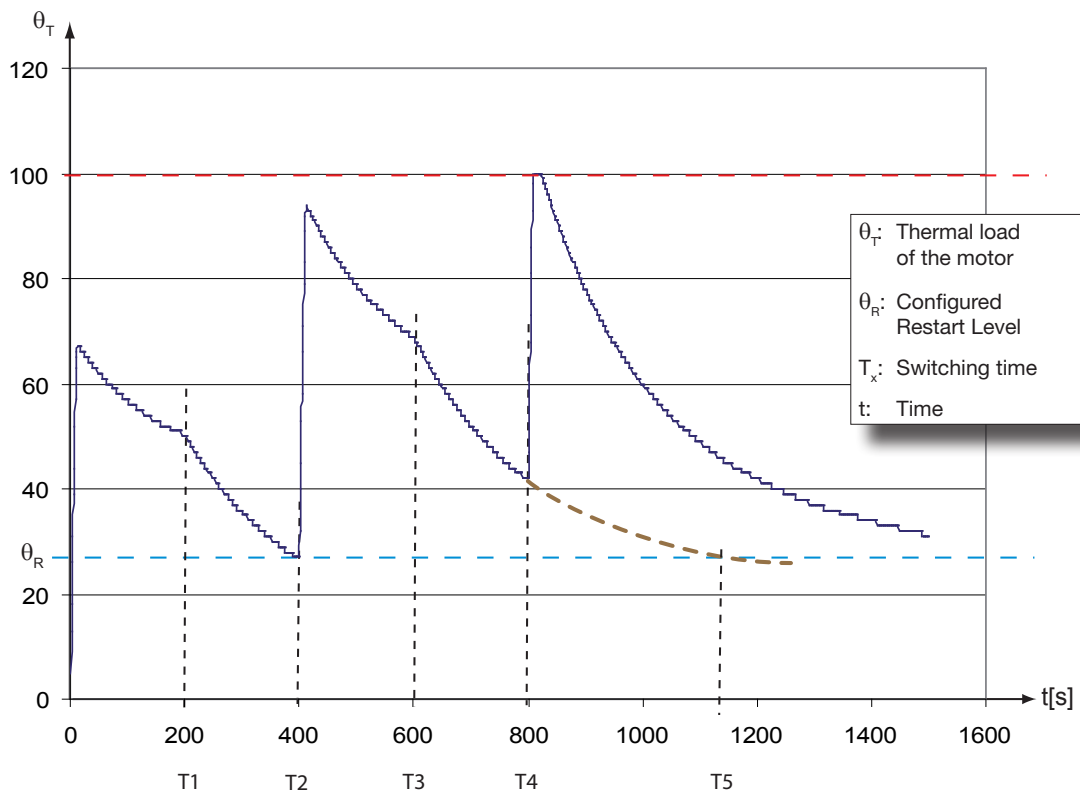

▲ Trend of the calculated motor temperature after several starts. The motor trips after the third start because the motor was started too frequently in the given time.

#### Relevant Parameters:

- Trip Class
- Set Current  $I_{e1}$  and optionally  $I_{e2}$
- Current Factor
- Cooling Mode

- Cooling Time
- Restart Level
- Thermal load Pre-Warning level
- Fault autoreset

# Universal Motor Controller

## UMC100-FBP

### Technical Description

#### Long Start, Locked Rotor Protection

This function detects a long start situation which is caused from a locked rotor for example. The function creates a trip if the motor current continuously exceeds a threshold for a configurable period of time. Blocking of a motor can occur due to excessive loading of the motor or due to process or mechanical jam. The early detection and tripping of the motor protects the driven mechanical system by further damage and the motor from thermal stress. This function can only trigger a trip. Both the maximum allowed current and the delay time until the trip occurs can be adjusted.

Block diagram:

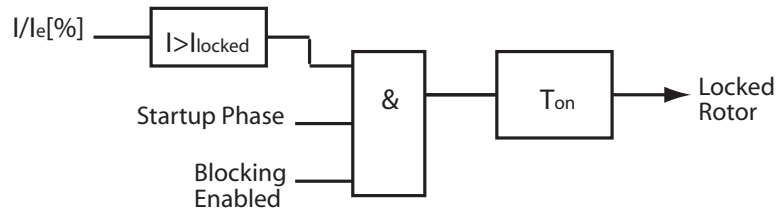

▲ Signal flow of the locked rotor protection function

	<p>To adjust the blocking current threshold correctly proceed as follows:</p> <ul style="list-style-type: none"> <li>• Take the highest inrush current value during a normal start. This value is displayed on the UMC100-PAN.</li> <li>• Add a safety factor depending on how much your start-up load might vary.</li> <li>• Set the blocking delay to a value that is shorter than the trip time resulting from the thermal overload trip at the given current.</li> </ul>
-----------------------------------------------------------------------------------	------------------------------------------------------------------------------------------------------------------------------------------------------------------------------------------------------------------------------------------------------------------------------------------------------------------------------------------------------------------------------------------------------------------------------------------------------------------------------

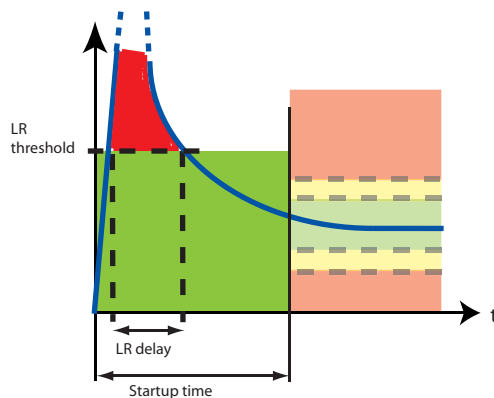

▲ Startup phase of a motor: If the motor current does not fall below the LR threshold within the configured LR delay time a locked rotor trip is triggered.

Relevant Parameters:

- *Locked Rotor Level*
- *Locked Rotor Delay*

# Universal Motor Controller

## UMC100-FBP

### Technical Description

#### High Current Protection

This function is useful to protect the driven mechanical system from jams and excessive overloads caused by the equipment or the process.

The high-current function signals a warning when the motor current exceeds a set threshold for a configurable period of time, after the motor start-up. The high current function creates a trip when the current continuously exceeds a separately set threshold for a set period of time, after the motor start-up.

#### Block Diagram:

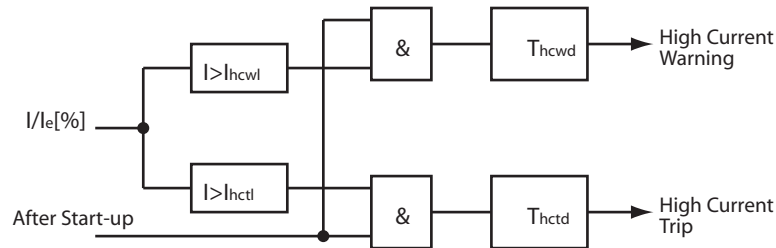

▲ Signal flow of the high current protection function.

#### Example:

The start-up phase ended at T1. At T2 the current increases above the high current warning level  $I_{hcwl}$  for a period longer than the high current warning delay time  $t_{hcwd}$ . Therefore the high current warning signal is set.

At T3 the current also increases above the high current trip level  $I_{hctl}$  but only for a period shorter than the specified high current trip delay time  $t_{hctd}$ . Then at T4 the current rises again above the trip level and stays there long enough to trigger an overcurrent trip that finally stops the motor.

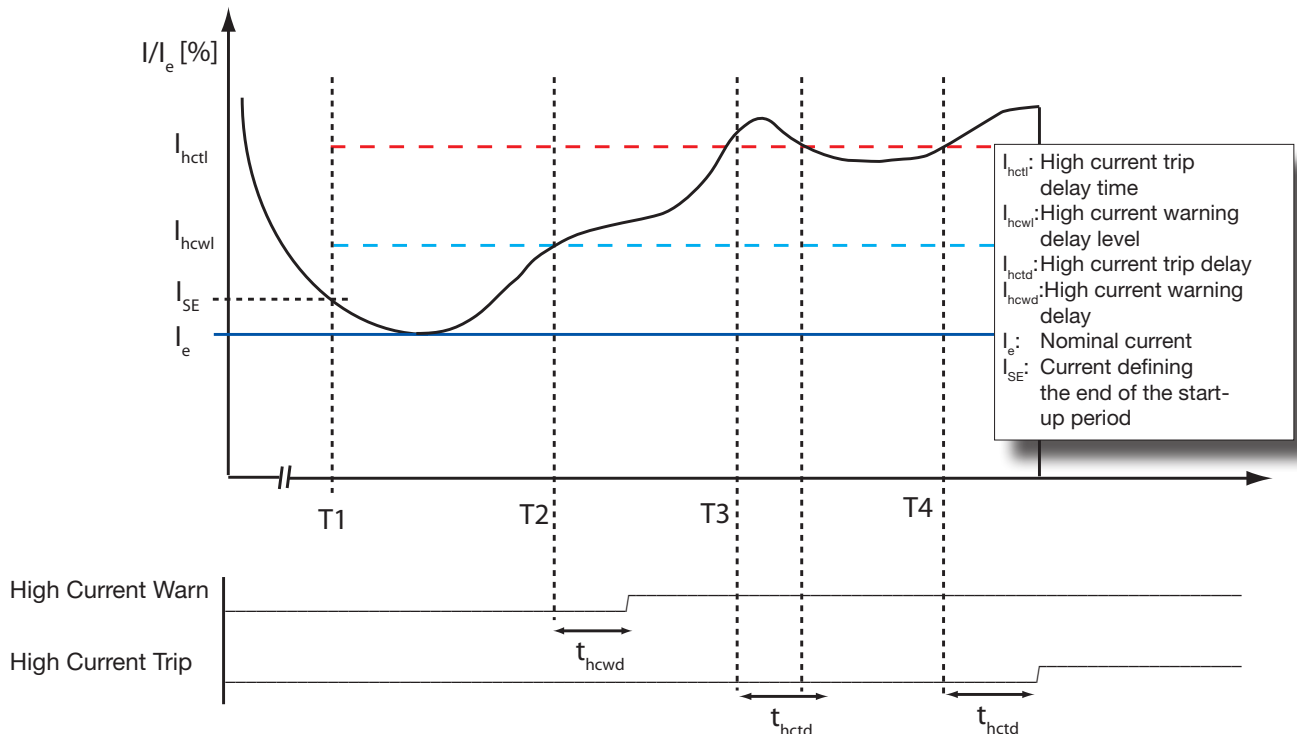

▲ Trend diagram of the motor current over time showing the function of the high current protection function with the related parameters.

#### Relevant Parameters:

• High Current Trip Level	• High Current Warning Level
• High Current Trip Delay	• High Current Warning Delay

# Universal Motor Controller

## UMC100-FBP

### Technical Description

#### Low Current Protection

The low current function is triggered when the motor current falls below a desired level. The function detects loss of suction for pumps, broken belt for conveyors, loss of airflow for fans, broken tools for machines etc. Such states do not harm the motor but early diagnosis helps to minimise the extent of damage to the mechanical installation and subsequent loss of production.

The motors on underload draw mainly the magnetising current and a small load current to overcome frictional losses. Therefore, the other reason to isolate the motors on underload is to reduce the reactive load on the power system network.

The low current function signals a warning when the motor current falls below the warning level for a configurable period of time, after motor start-up. The low current function creates a trip when the motor current falls below the trip level for a configurable period of time, after motor startup.

#### Block Diagram:

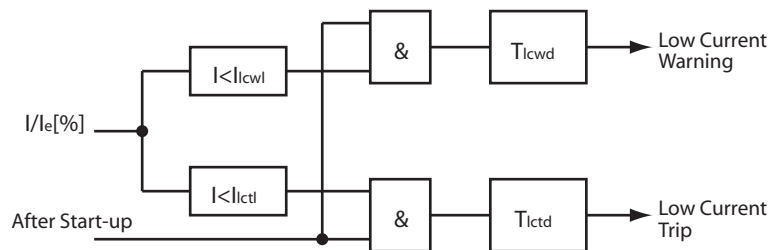

▲ Signal flow of the low current protection function.

#### Example:

The diagram above shows an underload situation of the motor after the startup time is over (T1). At T2 the motor current falls below the undercurrent warning limit  $I_{ucwl}$ . After the undercurrent warning delay time  $t_{ucwd}$  an undercurrent warning is set.

Then at T3 the current also falls under the undercurrent trip level  $I_{uctl}$  but only for a period shorter than the specified undercurrent trip delay time  $t_{uctd}$ . Therefore no trip happens. At T4 the current falls again under the low current level and stays there. Therefore a trip is released and the motor stopped.

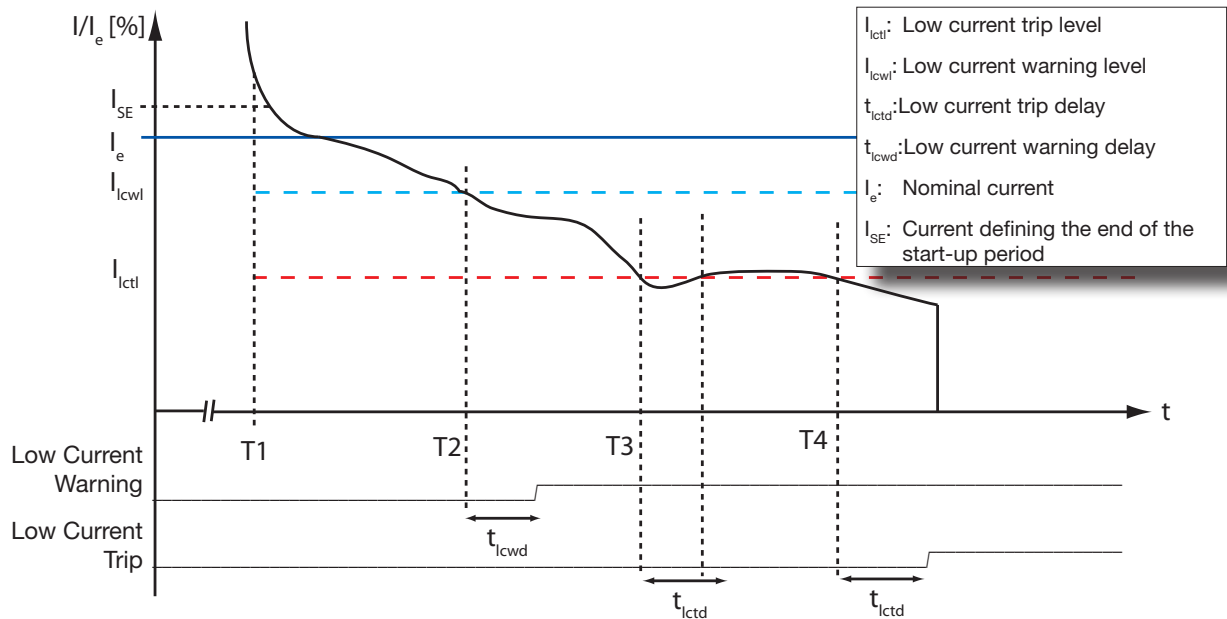

▲ Trend diagram of the motor current over time showing the function of the low current protection function with the related parameters.

#### Relevant Parameters

- |                           |                              |
|---------------------------|------------------------------|
| • Undercurrent Trip Level | • Undercurrent Warning Level |
| • Undercurrent Trip Delay | • Undercurrent Warning Delay |

# Universal Motor Controller

## UMC100-FBP

### Technical Description

#### Phase Loss Protection (Current)

This function protects motors against the extreme situation where a complete phase is lost. An undetected phase loss can cause motor damage because of the sudden rise of current in the two remaining phases. Thus the thermal overload protection performs an accelerated trip during phase loss. This function is based on the motor current and detects a phase loss while the motor is running.



The function is only active if the average of the motor current in the three phases is > 25 % of  $I_e$ .

The phase loss protection function must not be disabled in real applications. The phase loss protection may only be disabled for demo purposes.

To detect a phase loss the current in the remaining phases must be > 25% of  $I_e$ .

The following table shows the tripping times in case of phase loss for the different trip classes.

Trip class	5	10	20	30	40
Tripping time [s]	1.5	3	6	9	12

Relevant Parameters:

- Phase Loss Protection

#### Phase Imbalance Protection (Current)

The phase imbalance protection protects the motor against a smaller imbalance between the different phases.



The phase imbalance trip level must be carefully adjusted to protect the motor windings against overheating. Take care of rules or guidelines possibly provided by the motor manufacturer.

Function:

The current imbalance function signals a warning if the ratio between the lowest and the highest phase current in percent is above the configured warn level. A fix hysteresis is applied.

$$\text{Formula: Phase imbalance} = 100 \cdot (1 - I_{\min} / I_{\max})$$

The current imbalance function signals a fault if the ratio between the lowest and the highest phase current is above the configured trip level. The trip delay depends on the trip class setting and is shown in the table above.

This function is only active if the average current in the three phases is above > 25% of the nominal current  $I_e$ . In case of extreme imbalance value a phase loss might be signalled instead.

Blockdiagram:

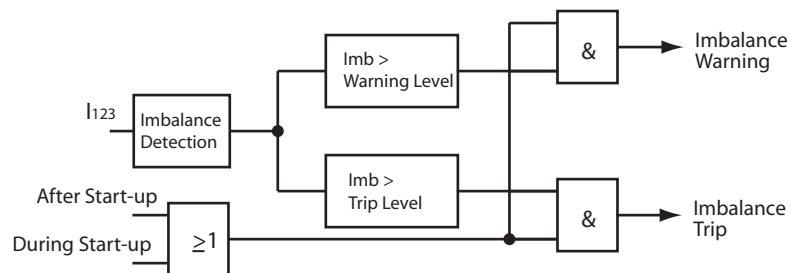

▲ Signalflow of the phase imbalance function

Relevant Parameters:

• <i>Curr Imb Trip Level</i>	• <i>Curr Imb Warn Level</i>
------------------------------	------------------------------

#### Phase Sequence Protection



# Universal Motor Controller

## UMC100-FBP

### Technical Description

#### Earth Fault Protection

The earth fault protection function protects the motor and the network against ground current flow. Earth faults are mainly caused due to ageing of the insulation, deterioration of insulation due to sustained or cyclic overloading, moisture or conductive dust.

The monitoring of the earth fault is carried out with the help of the auxiliary device CEM11 or based on an UMC100 internal calculation of the ground fault current.

Detection of ground faults can be used to interrupt the motor to prevent further damage, or to alert the maintenance personnel to perform timely maintenance.

#### Protection based on external earth fault detection device CEM11

The CEM11 device monitors if the sum of the three phase currents is zero. It using a current transformer where all 3 phases are feed through. The signalling output of the CEM11 can be connected to one of the multifunction inputs of the UMC. The earth fault signal can be optionally delayed. It is also possible to suppress the earth fault during the motor start-up phase.



- CEM11 can be used in all types of networks (grounded or ungrounded)
- Can be used also in networks with higher impedance to ground. Also small ground fault currents can be detected

#### Block Diagram:

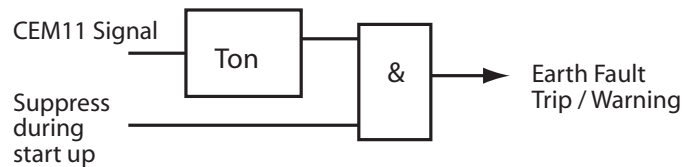

▲ Signal flow of the earth fault protection function

**Sample Circuit Diagram:** To use CEM11 with the UMC proceed as follows:

1. Select the CEM11 model that suits your application needs. There are four different models available with feed-through holes from 35mm to 120mm.
2. Connect the CEM11 to one of the multifunction inputs DO0, DI1 or DI2 and 24V DC supply.
3. Configure the corresponding multifunction input as earth fault input. You can select if the earth fault supervision shall be suppressed during motor start or not.
4. Optionally a time can be configured to delay the creation of a fault or warning. It is adjustable from 0.1 to 25.5 s.
5. Configure the threshold when an earth fault should be signalled. The threshold can be set directly at the earth fault monitor (CEM11) itself. See the CEM11 technical manual for further details.

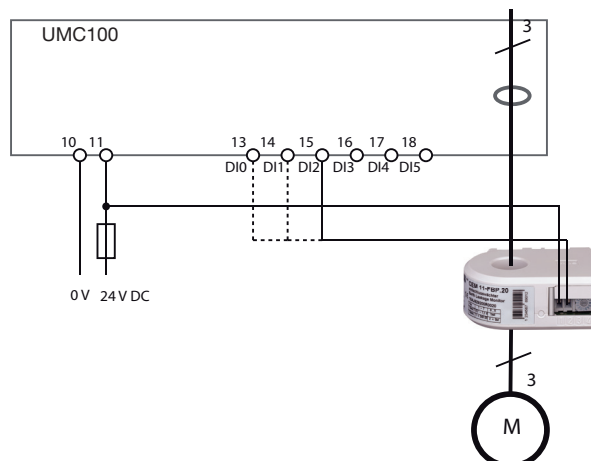

Relevant Parameters CEM11:

• Multifunction Delay Time

• Multifunction Inputs 0,1, or 2

# Universal Motor Controller

## UMC100-FBP

### Technical Description

#### Protection based on internal Calculation

The UMC can detect an earth fault by summing up the three phase currents **without** using an external current transformer.

The internal earth fault detection function signals a warning when the earth fault current exceeds a set threshold for a configurable period of time, after the motor start-up. The earth fault detection function creates a trip when the current continuously exceeds a separately set threshold for a set period of time, after the motor start-up.



- Ground fault current must be  $> 20\%$  of  $I_e$  to be detected
- Only usable in networks with low impedance to ground. Only higher ground fault currents can be detected
- The set trip and warn levels should not be above  $80\%$  of  $I_e$

#### Block Diagram:

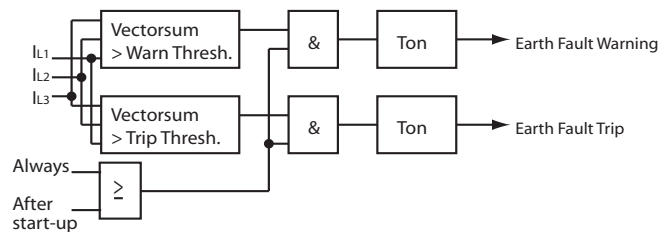

▲ Signal flow of the internal earth fault protection function

#### Relevant Parameters Internal Ground Fault:

• <i>Earth Flt Trip Level</i>	• <i>Earth Flt Warn Level</i>
• <i>Earth Flt Trip Delay</i>	• <i>Earth Flt Warn Delay</i>
• <i>Earth Flt Detection</i>	

# Universal Motor Controller

## UMC100-FBP

### Technical Description

#### Thermistor (PTC) Motor Protection acc. to EN 60947-8 (type A sensors)

PTC thermistors are semiconductor elements with a very high positive temperature coefficient. They are embedded directly in the phase windings of the stator. In contrast to the thermal overload protection that responds to the load current, the thermistor protection responds to the change in thermistor resistance due to temperature change in the motor windings.

The thermistors are selected to have a rated operating temperature that corresponds to the insulation class, type and construction of the motor. At the rated temperature the thermistor resistance increases sharply up to the hot temperature resistance value.

The UMC senses this abrupt change in the resistance. When thermistor protection is activated there is also an internal supervision which detects open or short-circuit faults from the thermistor circuit.

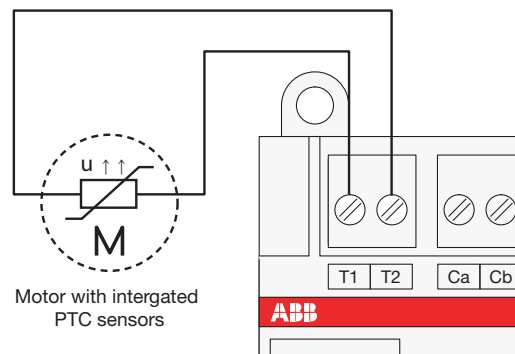



▲ Connect the PTC to the T1/T2 terminals of the UMC.

Relevant Parameters:

•PTC

#### Resistive Thermal Device (RTD) based Motor Protection

To protect motors with built in PT100 or PT1000 sensors a separate temperature monitoring relay must be used. The temperature monitoring relay is used to monitor the resistance of the temperature sensors embedded e.g. in the stator windings or the bearing of a motor. Depending on the relay type different thresholds for triggering a trip or pre-warning might be available. Read the manual of the RTD manufacturer for more information.

	Due to the fact that a separate monitoring device is used the actual temperature value is not available in the UMC100.
	You can set your own meaningful error message to inform a user about the trip reason - e. g. "Bearing hot". This message is then displayed on the LCD operator panel in case of a trip.

# Universal Motor Controller

## UMC100-FBP

### Technical Description

#### Voltage and Power Protection Functions

This section describes the voltage based motor protection functions. The UMC100 together with the voltage module VI150/VI155 continuously measures the motor supply voltage (line to line), the motor current and the phase angle between the current and voltage. The power and energy consumption is calculated out of these values and used for various protection and monitoring functions. The different process values can be reported to the fieldbus and displayed on the LCD panel.

The following functions are described in this section:

- Overvoltage, Undervoltage
- Phase loss
- Voltage imbalance
- Total harmonic distortion
- Overload, Underload
- Power factor
- Voltage Dip reaction

The following process data are available:

Process Value	Explanation	Data range
Powerfactor (cosphi)	The power factor is defined as the ratio of the real power flowing to the load to the apparent power and is a non dimensional number between 0 and 1 (also expressed as a percentage). The cos phi only considers the fundamental frequency.   In this manual both terms are used and refer to the fundamental frequency only!	0...1 (0 ... 100%)
$U_{L1L2}, U_{L2L3}, U_{L3L1}$	Phase to phase (line to line) voltages	0...115% of $U_e$
Active power	Active power is the capacity of the motor for performing work in a particular time	0...65535 [1W, 10W, 100W, 1kW] The actual unit depends on the selected scaling factor.
Apparent power	The apparent power is the vector sum of real and reactive power.	0...65535 [1VA, 10VA, 100VA, 1kVA] The actual unit depends on the selected scaling factor.
Voltage Imbalance	An imbalance between the supply voltages in the network.	0...100%
Total harmonic distortion (THD)	Harmonic distortion of the mains.	0 ... 100%
Energy	Consumed energy.	kWh



In section 2 -> *Connecting the VI15x Voltage Module* you will find information on how to mount and connect the voltage module.

All process values generated from the voltage module can be used in the Custom Application Editor. Consult the editor's manual for more information.

The digital output of the voltage module 1DO0 can be freely used in the function block editor. By default it is connected to the command telegram and can be controlled from a PLC.



Before using the voltage module set the following parameters:

- *Nominal line to line voltage*
- *Nominal power factor (cos phi)*
- *VI15x enabled*. If the module is enabled the UMC monitors the presence of the module and creates by default a fault in the event that the module is missing (-> parameter 'Missing Module Reaction').

# Universal Motor Controller

## UMC100-FBP

### Technical Description

#### Function Overview

Protection Function	When active	Available Options: Warning/Trip/ Off/Other	Automatic Fault Reset Possible
Overvoltage: The highest value of the three phases is above a given threshold. The warning - and trip thresholds as well as the according delays can be set.	Motor running Motor stopped Not in test position	Trip, Warning, Off	-
Undervoltage: The lowest value of the three phases is below a given threshold. The warning - and trip thresholds as well as the according delays can be set.	Motor running Motor stopped Not in test position	Warning	-
Voltage Dip: Low voltage situation which requires and autonomous load shedding handling should take place in the UMC.	After motor start Not in test position	Reaction depends on Dip duration.	-
Phase loss: In opposite to the current based phase loss protection function this function detects a missing phase also in the case the motor is stopped. A warning / trip can be signalled before the motor is actually started i.e. to detect a blown fuse.	Motor running Motor stopped Not in test position	Trip, Warning, Off	Yes, see parameter ' <i>Fault auto reset</i> '
Voltage imbalance: This function can be used to detect smaller voltage imbalances between the phases. Warning - and trip thresholds as well as warning - and trip delays can be set.	Motor running Motor stopped Not in test position	Trip, Warning, Off	-
Total harmonic distortion: This function measures harmonic distortions in the connected mains.	Motor running Motor stopped Not in test position	Warning	-
Overload: The active power drawn by the motor is too high. The warning - and trip thresholds as well as the according delays can be set.	After load start Not in test position	Trip, Warning, Off	-
Underload: The active power drawn by the motor is too low. The warning - and trip thresholds as well as the according delays can be set.	After load start Not in test position	Trip, Warning, Off	-
Cos phi: A measure of the phase angle between voltage and current. The warning - and trip thresholds as well as the according delays can be set.	After load start Not in test position	Trip, Warning, Off	-

# Universal Motor Controller

## UMC100-FBP

### Technical Description

#### Voltage based Protection Functions

The following block diagram provides an overview of the signal flow related to voltage supervision and protection. The different voltage protection functions are usually always active (also if the motor is in stop mode). There are two exceptions a) if the UMC is in test position and b) if a voltage Dip was detected.

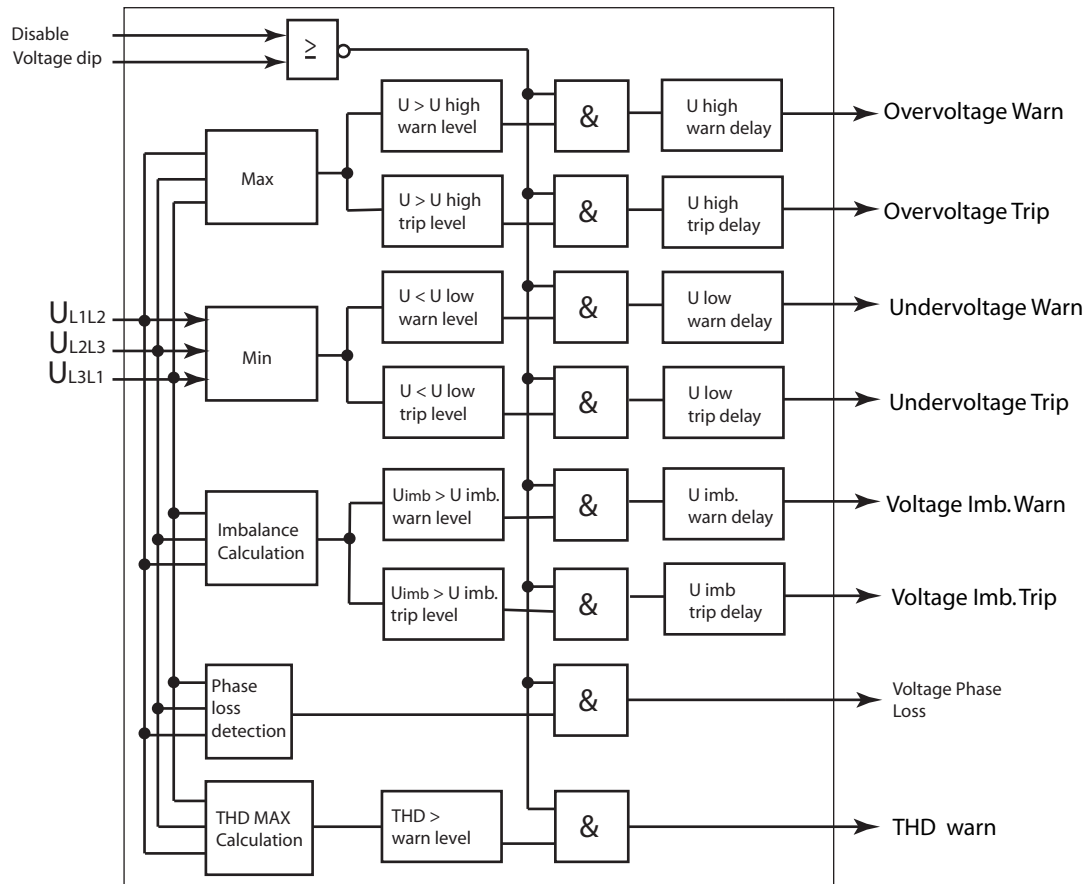

▲ Signal flow of the voltage based protection and monitoring functions.

#### Imbalance

An imbalance can appear because of different reasons. For example because of a network imbalance or because of high contact resistances in the wiring of a phase. Even small voltage imbalances causes high current imbalances. The imbalance value is calculated as follows:

$$value = \frac{MaxDeviation(U_{12}, U_{23}, U_{31})}{Average(U_{12}, U_{23}, U_{31})}$$

$$U_{imbalance} = \begin{cases} U_{xy}/U_e < 10\% \mapsto 0\% \\ value \geq 20 \mapsto 20\% \\ value < 20 \mapsto value \end{cases}$$

#### Total Harmonic Distortion

This function measures harmonic distortions in the connected mains and provides a value for Total Harmonic Distortion THD. Harmonic distortions can be caused by variable speed drives or other electronic devices. High harmonics can result in accelerated degradation of insulation and loss of service life of a motor. In case of distortions above the adjustable warnlevel, it is recommended to check the supply mains for faults or noisy equipment. The THD is defined as the ratio of the sum of the powers of all harmonic components to the power of the fundamental frequency.

A threshold can be set to trigger a warning if the THD is too high.

# Universal Motor Controller

## UMC100-FBP

### Technical Description

#### Power Factor and Power Supervision

The power factor and the active power are important values to detect underload or no-load situations in applications where a change of the load is not equally reflected in a change of the motor current (e.g. small pumps, conveyor belts etc.). For the supervision of the power factor a warning and a trip threshold is available.

The power factor together with the motor current and the supply voltage are the basis to calculate the real power consumed by the motor. Warning and trip thresholds can be set both for overpower and underpower supervision.

The power factor and power supervision functions are disabled in test position and if a voltage Dip was detected.

An adjustable inhibit time is available to inhibit the load supervision functions after load start. This can be used for example to allow a pump to built up pressure before the power protection becomes active. The diagram below shows the startup of a motor and the activation of the underload protection function.



It is not necessary to specify the nominal power of the motor. The UMC100 internally calculates it as follows:

$$P_{nom} = I_e * U_e * \cos\varphi_{nom} * \sqrt{3}$$

The warning and trip thresholds for the under - and overpower protection are therefore defined as percentage in relation to  $P_n$ . Example:  $P_n = 2\text{kW}$ . If the parameter '*P Low Trip Level*' is set to 80%' the motor will be tripped if the measured real power falls below 1.6kW.



Use either the cos phi or the active power for low load supervision. It is not recommended to use both at the same time.

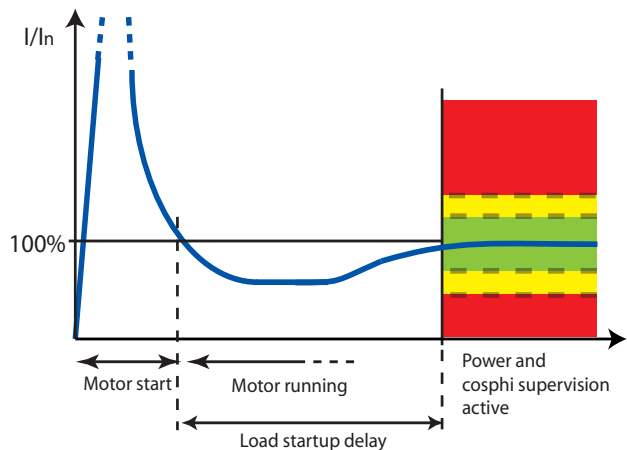

- ▲ The load startup delay time allows to delay the low-power protection functions at start-up. This can be used for example to allow a pump to built up pressure before the low power protection becomes active.

# Universal Motor Controller

## UMC100-FBP

### Technical Description

The following block diagram shows the data flow of the power supervision in the UMC/VI15x and the generated signals.

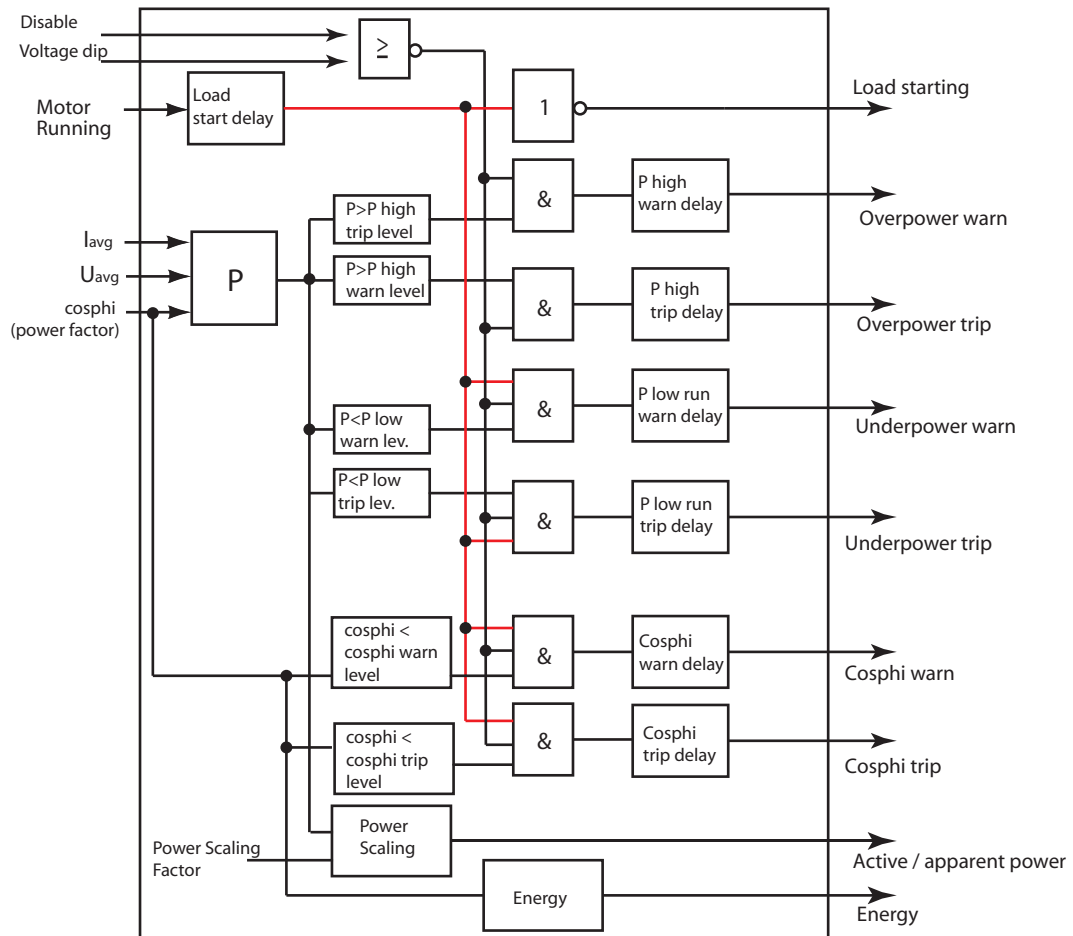

▲ Block diagram showing the data flow of the power protection function. The signals on the right are available for further processing e.g. in a user defined custom application.

Relevant Parameters Voltage	Relevant Parameters Power
• <i>U High Warn Level</i>	• <i>PwrFactor Warn Level</i>
• <i>U High Trip Level</i>	• <i>PwrFactor Trip Level</i>
• <i>U High Warn Delay</i>	• <i>PwrFactor Warn Delay</i>
• <i>U High Trip Delay</i>	• <i>PwrFactor Trip Delay</i>
• <i>U Low Warn Level</i>	• <i>Load Startup Delay</i>
• <i>U Low Trip Level</i>	• <i>P Low Trip Delay</i>
• <i>U Low Warn Delay</i>	• <i>P Low Trip Level</i>
• <i>U Low Trip Delay</i>	• <i>P Low Warn Delay</i>
• <i>U Imb. Warn Level</i>	• <i>P Low Warn Level</i>
• <i>U Imb. Trip Level</i>	• <i>P High Trip Level</i>
• <i>U Imb. Warn Delay</i>	• <i>P High Trip Delay</i>
• <i>U Imb Trip Delay</i>	• <i>P High Warn Level</i>
• <i>THD Warning Level</i>	• <i>P High Warn Delay</i>
• <i>THD Warning Delay</i>	• <i>Power Scale Factor</i>

# Universal Motor Controller

## UMC100-FBP

### Technical Description

#### Voltage Dips, Load Shedding

Motors switched off during voltage Dips or power failure can be restarted on power resumption sequentially to prevent simultaneous switch-on of the motors and thus prevent another mains failure on the network. The tripping of motors due to undervoltage of short duration can be bypassed. It is also possible to restart the process on power resumption by sequentially starting the motors (staggered start).



The Voltage Dip function is available for the starter types DOL (Direct Online Starter) and REV (Reversing Starter).



When using the voltage dip function take care about the availability of the contactor supply voltage and the contactor fallback. Set the check back delay time > the auto restart window to avoid trips before the UMC has switched off the contactor if the Dip is longer than the auto restart window.



During a voltage dip the UMC inhibits low voltage, low cos phi and low power warnings and errors. Nevertheless set a sufficient delay time of e.g. min. 0.5s for these functions to avoid conflicts with the voltage Dip function.



During a voltage dip the supply voltage of the UMC itself must be available! For special applications where the supply voltage is switched off too you can create an own function block application using the function block editor and using the function block 'Non Volatile SR'. This block allows to save its output state over a power cycle.

The load shedding logic can be triggered

a) from the VI15x voltage module. See upper part of the diagram below.

b) from an external voltage monitor signalling the low voltage situation to several devices. See lower part of the diagram below. No VI15x module is needed in this case.

The following diagram shows both solutions.

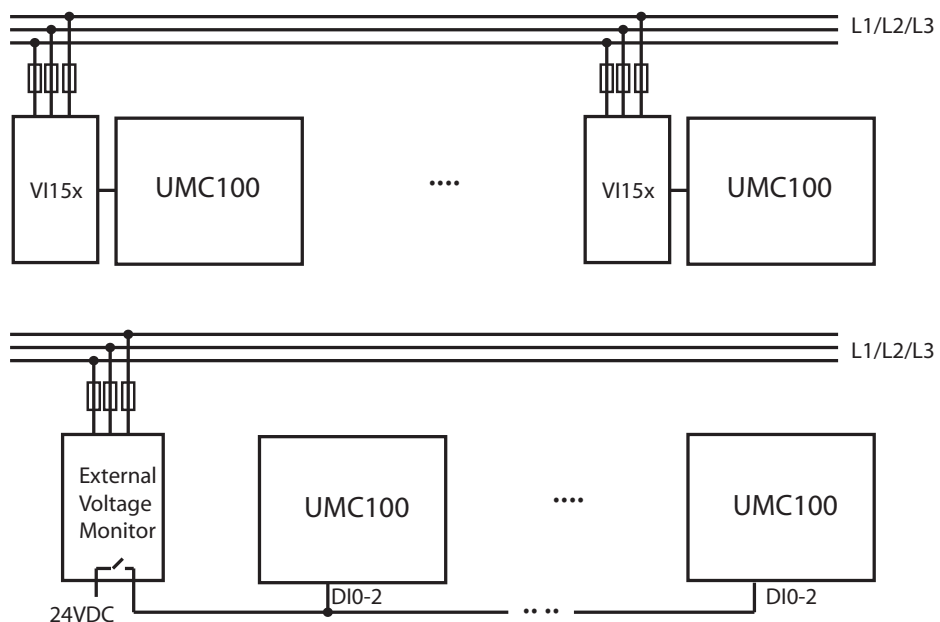

▲ A low voltage situation can be detected either by the VI15x module or using an external voltage monitoring relay. In the latter case the low voltage signal has to be wired to all motor controllers.

# Universal Motor Controller

## UMC100-FBP

### Technical Description

#### Parameter Description

Parameter	Explanation
Dip Duration	If the voltage Dip is longer than this time a 'Dip Duration' error is triggered.
Dip Autorestart Window	If the voltage recovers within this time the motor is not switched off - i.e. the UMC output relay is switched on.
Dip Autorestart Delay	The time delay until the motor is restarted after the end of a voltage Dip. This is done only if the parameter 'Dip Autorestart Enable' is set.
Dip Enable	Dip function is enabled.
Dip Autorestart Enable	Activate the automatic restart.
Dip Level	Voltage level indicating the begin of a voltage Dip
Dip Restart Level	Voltage level indicating the end of a voltage dip.

Depending on the duration of a voltage Dip and the parameters above different reactions can be configured.

The following four diagrams show different cases.

- Case a: short low voltage situation. The motor keeps running.
- Case b: longer low voltage situation with motor stop. The motor is automatically re-started after a delay.
- Case c: long low voltage situation triggering an error
- Case d: two Dips within a short period of time

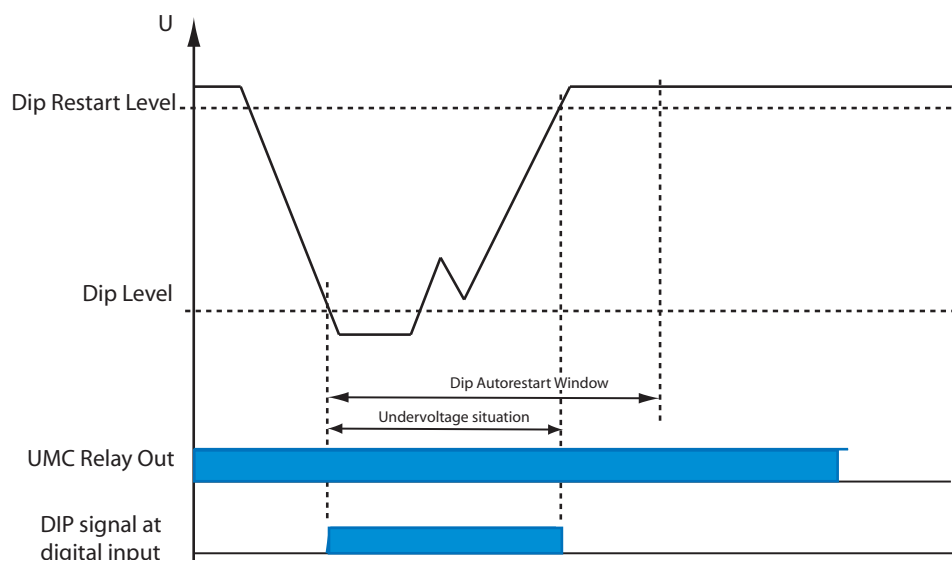

▲ Case a: The low voltage situation is shorter than the '*Dip Autorestart Window*' so the UMC output relay does not open. The motor keeps running without interruption.

# Universal Motor Controller

## UMC100-FBP

### Technical Description

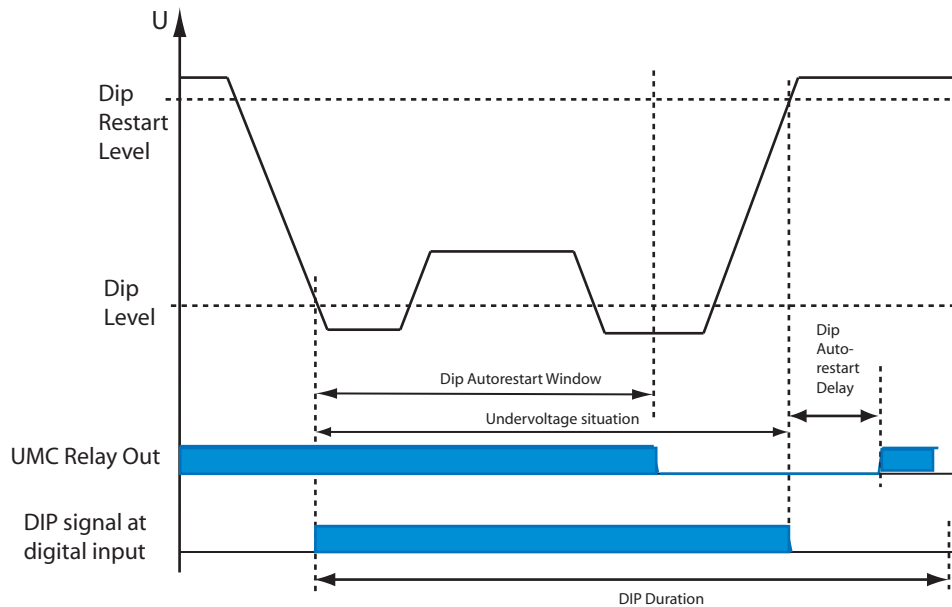

▲ Case b: The low voltage situation takes longer than the configured 'Dip Autorestart Window' which means the UMC switches off the relay output. But the low voltage situation is shorter than the configured 'Dip Duration' so the motor gets started automatically after an optional restart delay time (Parameter 'Dip Autorestart Enable=On'). Otherwise it stays off.

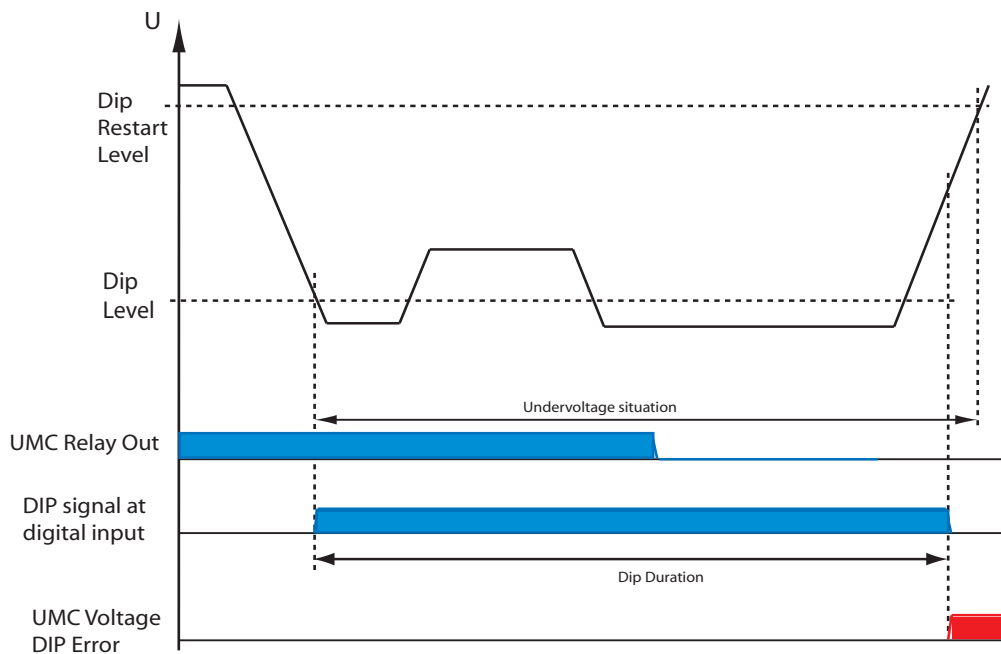

▲ Case c: The low voltage situation takes longer than the 'Dip Duration' time. Therefore an error is generated as soon as the Dip duration exceeds the configured Dip duration time.

# Universal Motor Controller

## UMC100-FBP

### Technical Description

#### Double Dips

Special handling can be activated if two Dips occur within one second. Set parameter '*Dip Enable*' to '*On + Rapid Cycle Lockout*'. If within one second two low voltage situations occur, immediately after the start of the second low voltage situation the contactors are switched off. They are automatically switched on again after the '*Dip Autorestart Delay*' time if '*Dip Autorestart Enable*' is set.

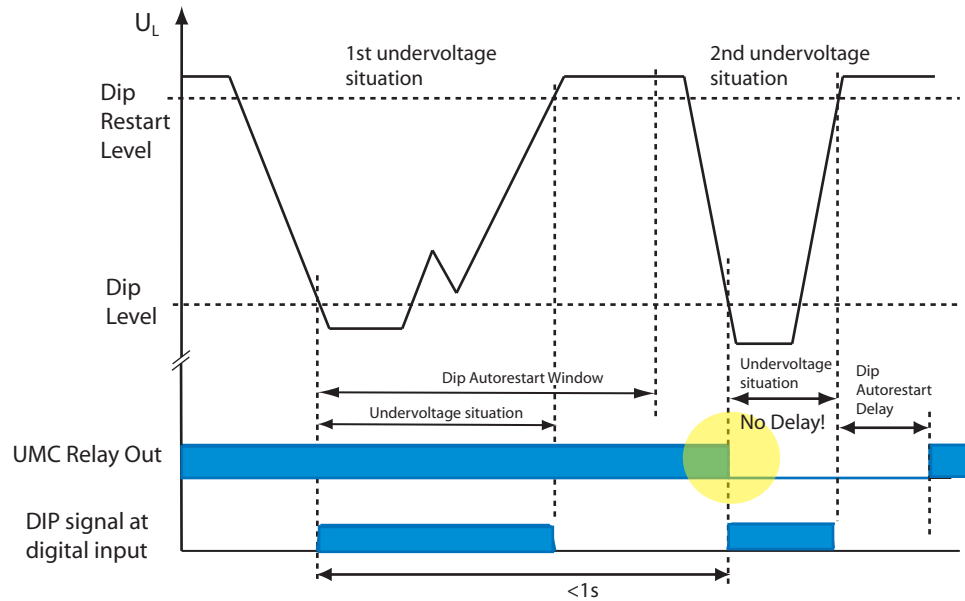

#### Relevant Parameters:

- *Dip Enable*
- *Dip Duration*
- *Dip Autorestart Window*
- *Dip Autorestart Delay*

- *Dip Autorestart Enable*
- *Dip Level* (only when using the VI15x modules as trigger source)
- *Dip Restart Level* (only when using the VI15x modules as trigger source)

# Universal Motor Controller

## UMC100-FBP

### Technical Description

## 5 Configuring the Motor Management Functions

In this section you find the following information:

- Introduction into the supported control stations and operation modes
- How to start and stop the motor from the different control stations
- Available control functions
- Functions related to motor control such as emergency start, checkback monitoring etc.

### Starting and Stopping the Motor

#### Control Stations

From control stations (i.e. source of commands) start/stop commands can be sent to the UMC. Four control stations are supported:

- **Digital Inputs:** Allow the motor to be controlled from a control panel with push buttons e.g. mounted locally to the motor.
- **DCS/PLC:** Commands are transferred via cyclic communication telegrams from the process controller via fieldbus to the UMC. The UMC uses the PNO motor starter profile which defines the meaning of each bit in the cyclic telegrams. See section XXX for further details.
- **LCD-Panel:** Allows control via the buttons of the UMC-PAN usually mounted in the switchgear cabinet door
- **Service Tool:** Allows control commands to be issued via acyclic communication services of the used fieldbus. The UMC DTM uses this communication channel for example.

For each control station you can configure if a start and/or a stop command is accepted by the UMC.

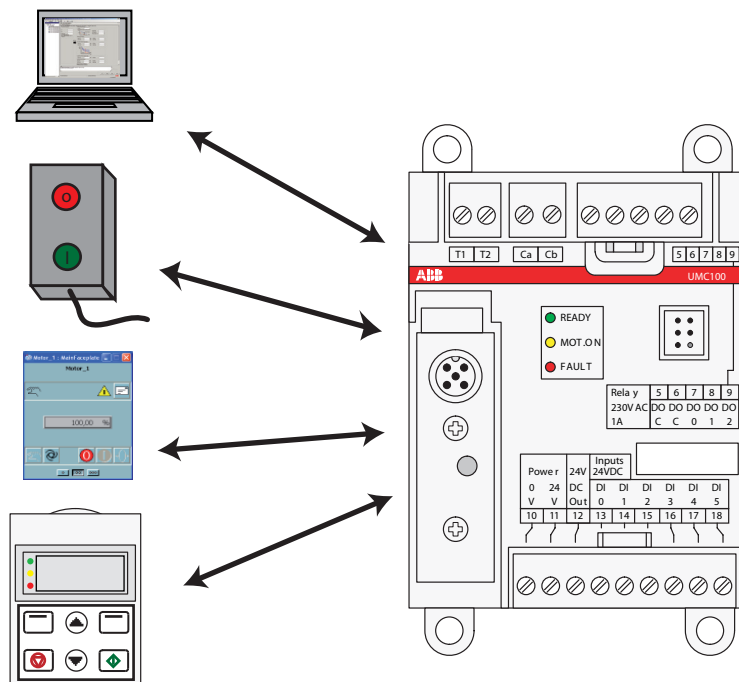

#### Modes

In practise it is often required to release or block start/stop commands from a control station depending on various reasons e.g.

- If the communication to the bus master is interrupted you want to automatically enable control via digital inputs which would not be possible if the communication is ok
- For service purposes all commands from the bus should be ignored

# Universal Motor Controller

## UMC100-FBP

### Technical Description

Therefore the UMC enables start/stop commands to be individually released or blocked from a control station depending on modes. Three different modes are available named by their typical usage:

Mode	Default Behaviour
<b>Auto (Remote)</b>	In this operation mode the UMC accepts start commands from the DCS/PLC. To activate this control mode the "Auto Mode Bit" in the cyclic communication telegram must be set to logic one. No start commands from other control sources are accepted in this mode.
<b>Local 1</b>	In this mode the motor is controlled locally at the motor or the motor control room. Start commands are accepted from the digital inputs or the LCD control panel. This mode is active in the following cases: <ul style="list-style-type: none"> <li>• If the "Auto Mode Bit" in the cyclic bus telegram is not set i.e. the PLC/DCS has enabled local control.</li> <li>• If the LCD panel is used to control the motor locally. As soon as the menu point "Motor Control" is entered and the UMC signals local control</li> <li>• If the UMC detects a bus fault</li> </ul>
<b>Local 2</b>	Is a second local control mode that can be activated via one of the multifunction inputs even if another mode is active. This allows local control to be enforced via digital inputs without involvement of the PLC/DCS (i.e. the "Auto Mode Bit" is ignored).

#### How to set the mode:

There are three relevant signals that determine which mode is active:

- Bus fault: The UMC has detected a bus fault (i.e. the cyclic bus master is missing)
- Force Local 2: A multifunction input signals that the local 2 mode shall be activated
- Autobit: With bit 5 in byte 0 of the cyclic command telegram, the PLC/DCS signals that the auto mode shall be activated and control shall happen via bus (according to PNO motor management profile).

The following table shows the activated operation mode depending on these inputs. There is always one mode selected even if more than one input is active. The bus fault signal has the highest priority followed by the force local 2 signal. The autobit has lowest priority.

Bus fault (e.g. no sign of life from master)	1	0	0	0
Force local 2 signal (from DI0-2)	x	0	1	0
Autobit is set to true on FieldbusBus	x	0	x	1
Resulting Mode	Local 1	Local 1	Local 2	Auto

x: Either 0 or 1

- ▲ Mode selection table. Based on the three inputs the active mode is selected.

# Universal Motor Controller

## UMC100-FBP

### Technical Description

#### Example:

The following requirements shall be fulfilled:

- Switch S1 has the following positions: Remote/Local/Test Position/Off.
- (Req. 1) If the switch is in position *Local* the UMC can only be controlled locally (digital inputs and LCD) but not started via bus. But it shall be possible to stop the motor also via bus.
- (Req. 2) In position *Auto* the DCS can control the UMC. Locally only a stop command can be issued.
- (Req. 3) In position *Off* the motor cannot be started at all
- (Req. 4) Position *Test* is for commissioning purposes and switches the UMC in simulation mode.
- (Req. 5) If there is a bus fault the UMC shall automatically go into local mode and allows starting/stopping via the LCD panel and the digital inputs (as in position *Local*).

The diagram below shows the simplified circuit diagram:

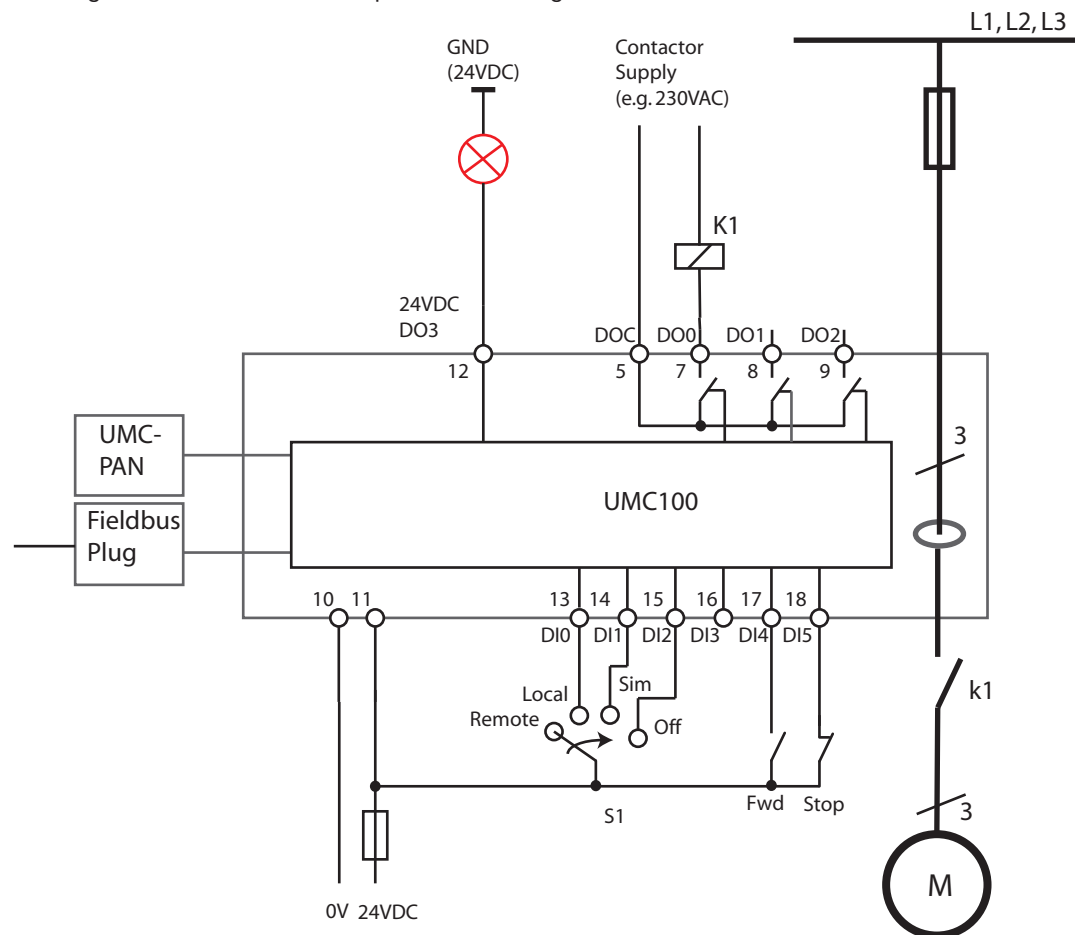

From the requirements you can see that the three control places Digital Inputs, Fieldbus and LCD are used. Furthermore start/stop commands from the different control places shall be blocked or released depending on the Fieldbus and S1 status. Therefore the different modes can be used.

To read in the S1 commands the three multifunction inputs DI0, DI1 and DI2 are used. Their configuration is as follows:

- Multifunction In 0 = Force Local (NO): This input activates local 2 mode if the user wants to ensure that the DCS cannot control the motor (Req 1)
- Multifunction In 1 = Test Position (NO): This input activates simulation (Req. 4)
- Multifunction In 2 = Stop: Stop (NO) is dominant and no start is permitted if the input is active (Req. 3)

For the Remote position no input is needed, because if the UMC is not in local mode, it is automatically in Auto mode

Finally it is necessary to configure from which control places the motor can be started in the different operation modes (Auto / Local ).

# Universal Motor Controller

## UMC100-FBP

### Technical Description

The following parameters are set according to the requirements (Req 1, Req2, Req 5):

Settings for local mode 1 (For busfault situation)

Loc 1 Start Bus Cyc = YES (Req. 1)  
 Loc 1 Stop Bus Cyc = NO  
 Loc 1 Start DI = YES (Req 5)  
 Loc 1 Stop DI = YES (Req 5)  
 Loc 1 Start LCD = YES (Req 5)  
 Loc 1 Stop LCD = YES (Req 5)  
 Loc 1 Start Bus Acyc = NO  
 Loc 1 Stop Bus Acyc = NO

Settings for Auto/Remote mode (S1 in position Remote)

Auto Start Bus Cyc = YES (Req 2)  
 Auto Stop Bus Cyc = YES (Req 2)  
 Auto Start DI = NO  
 Auto Stop DI = YES (Req 2)  
 Auto Start LCD = NO  
 Auto Stop LCD = YES  
 Auto Start Bus Acyc = YES  
 Auto Stop Bus Acyc = YES

Settings for local mode 2 (Switch S1 in position Local)

Loc 2 Start Bus Cyc = NO  
 Loc 2 Stop Bus Cyc = YES (Req. 1)  
 Loc 2 Start DI = YES (Req. 1)  
 Loc 2 Stop DI = YES (Req. 1)  
 Loc 2 Start LCD = YES (Req. 1)  
 Loc 2 Stop LCD = YES (Req. 1)  
 Loc 2 Start Bus Acyc = NO  
 Loc 2 Stop Bus Acyc = NO

The following diagram shows the simplified UMC internal data flow if S1 is in position *Remote* as shown in the circuit diagram before. On the left side there are the four blocks representing the control stations. Only three of them were required in the example. In the middle the so-called command control selection block is displayed. On the right the starter function block is displayed. The configuration is as above. A cross represents a YES, an empty field a NO. The active mode is REMOTE/AUTO as defined by S1. Therefore the DCS can start the motor. Other start commands (as indicated by DI4) will be blocked.

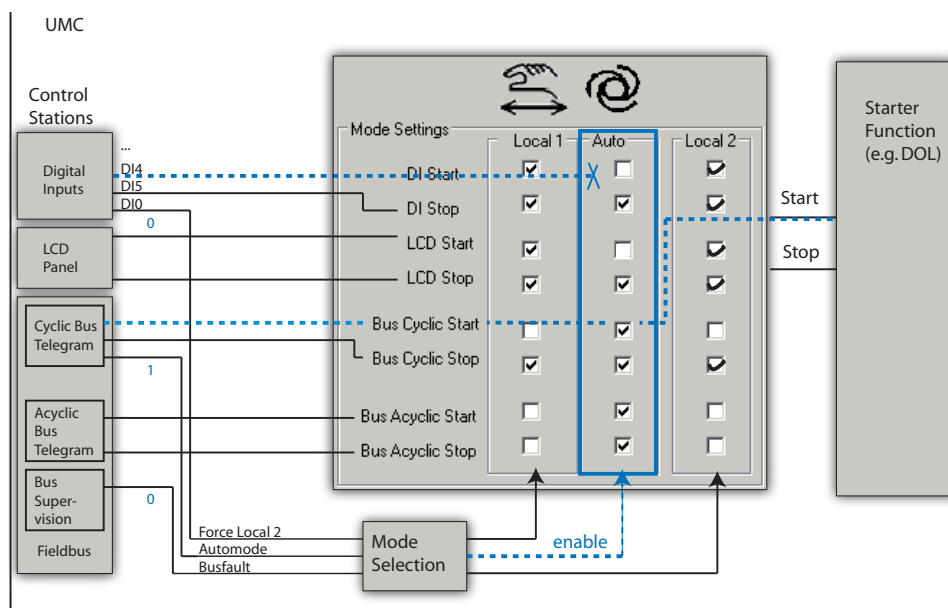

#### Activating Inching Mode

---

# Universal Motor Controller

## UMC100-FBP

### Technical Description

---

By default "pulses" are used to issue a start command. This means that a start input has to change its logic level to issue a start command - i.e. it is edge triggered. After the start command was accepted from the UMC the input signal can be set back to its initial value (e.g. zero).

For a start signal sent from the digital inputs (DI4/DI5) it is possible to change the behaviour from pulse mode to inching mode. This means that the motor is only running while the start signal is present. If it is not present anymore the motor stops automatically.

#### **Relevant Parameters:**

- For each of the three modes Local Control 1 (Loc1), Local Control 2 (Loc2) and Auto (Auto) the following parameters are available
  - *Start bus cyclic*
  - *Stop bus cyclic*
  - *Start LCD*
  - *Stop LCD*
  - *Start bus acyclic*
  - *Stop bus acyclic*
  - *Start DI*
  - *Stop DI*
- *Jog via DI (inching mode)*
- *Invert start DI*
- *Invert stop DI*

---

# Universal Motor Controller

## UMC100-FBP

### Technical Description

---

#### Emergency Start

In some special cases a motor must be started even if the thermal overload protection would prevent the start (i.e. cooling time is still running). To allow the start in such situations the thermal memory of the UMC can be reset to cold state. This enables an immediate restart even after a thermal overload trip.

There are two possibilities for an emergency start:

Using the multifunction inputs DI0, DI1 or DI2 an emergency start is carried out as follows:

1. Parameterise DI0, DI1 or DI2 as emergency start input
2. Switch the signal on the parameterised input to 1:
  - 0 -> 1 transition to reset the UMC100 thermal memory to "cold motor"
  - Continuous 1-signal to ignore fault signals on multi-function inputs (if parameterised as fault inputs)
  - Switch on motor

To perform an emergency start from the control system / fieldbus, the following steps must be carried out:

1. Set Parameter Emergency = On (default is Off)
2. Send command PREPARE EMERGENCY START 0->1 transition via fieldbus to reset the UMC100 thermal memory to „cold motor“. A continuous 1-signal ignores fault signals originating from the multi-function inputs (if parametrized as fault inputs)
3. Switch on motor



Caution: Starting a hot motor can cause motor damage or destruction of the motor.

Relevant Parameters:

- *Emergency Start*
- *Multifunction 0,1,2*

#### Limit the Number of Starts

This function allows to limit the number of starts withing a defined time window. The length of the window can be set with the parameter "*Num Starts Window*". The numbers of permissible starts in this window can be set with parameter "*Num Starts Allowed*".

If there is only one start left a user defined reaction can be triggered. See parameter "*Num Starts Pre-warn*". If no start is left anymore but a start command is given a user defined reaction can be triggered. See parameter "*Num Starts Overrun*".

An optional pause time "*Num Starts Pause*" can be set to define a waiting time after the motor was stoped that has to pass until a new start is possible. The running pause time is indicated with a flashing "t" symbol on the LCD panel. The remaining time until a new start is possible can be also displayed on the LCD panel and sent via fieldbus.

# Universal Motor Controller

## UMC100-FBP

### Technical Description

Parameter combinations:

Num Starts Allowed	Num Starts Window	Num Starts Pause	Resulting Behaviour
0	0	0	Function not active. (Default)
0	> 0	x	
> 0	0	x	
0	0	> 0	Number of starts not limited but pause between starts active
> 0	> 0	0 or > 0	Number of starts limited, window active (and pause active)

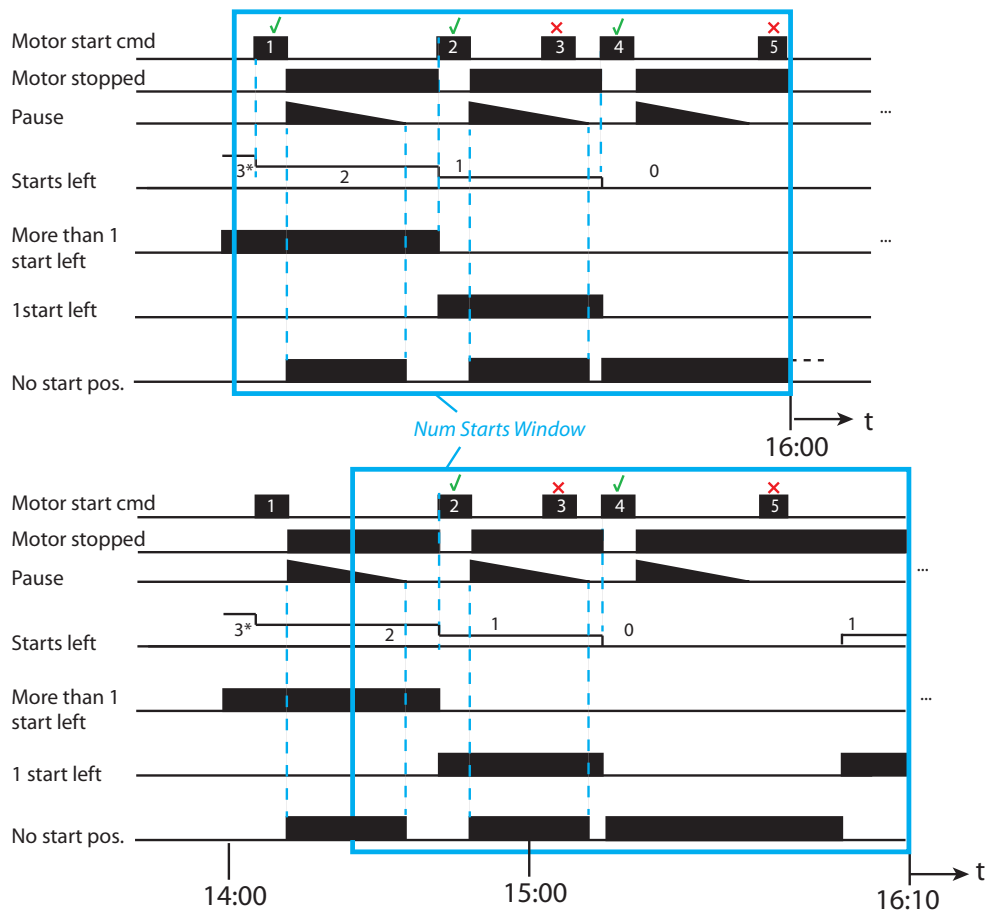

▲ Example with 'Num Starts Allowed' set to 3' shown at two points in time. Once at 16.00 o'clock and then 10 min. later.  
 Top: The 1st and 2nd start were successful. The 3rd start command was given before the pause time was over and was ignored therefore. Then the 5th start was ignored too because only 3 starts are allowed in the time window.  
 Bottom: The same situation is shown 10 min. later. One start is possible again because the first start was already shifted out of the monitoring window.

<b>Relevant Parameters:</b> <ul style="list-style-type: none"> <li>• Num Starts Allowed</li> <li>• Num Starts Window</li> <li>• Num Starts Pause</li> </ul>	<ul style="list-style-type: none"> <li>• Num Starts Overrun</li> <li>• Num Starts Prewarn</li> </ul>
----------------------------------------------------------------------------------------------------------------------------------------------------------------	------------------------------------------------------------------------------------------------------

\*) Initial counter setting depends on the parameter "Num Starts Allowed"

---

# Universal Motor Controller

## UMC100-FBP

### Technical Description

---

#### Checkback Monitoring

The UMC can be parameterised to monitor that the motor was really started using a checkback signal. By default the actual motor current is monitored. But it is also possible to use an auxiliary contact mounted on the main contactor.

If checkback monitoring via motor current is active it is checked that the measured current rose above 20 % within the Checkback Delay Time ( $t_{cbd}$ ) after switching on the main contactor. Otherwise when the motor is switched off the function checks that the motor current is zero at the latest after the Checkback Delay Time.

For checkback via contactors one or more auxiliary contacts must be installed and wired to the UMC's digital input DI0. The number of monitored signals depends on the selected control functions which are described in the following sections.

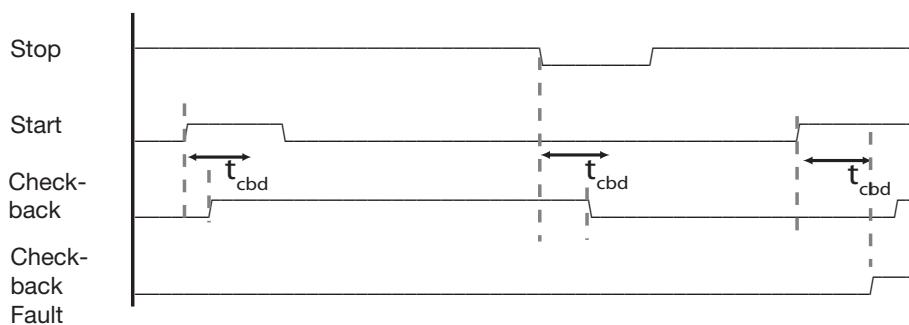

#### Related Parameters

- *Checkback Time*
- *Checkback Mode*

#### Using the Digital UMC Inputs

The UMC inputs DI0 ... DI5 are digital inputs according to IEC61131. They can be used to connect status and control signals to the UMC. UMC's reaction to these signals can be adapted in a wide range to cover typical user needs (e.g. starting the motor). The status of each digital input is available in the monitoring telegram sent to the PLC/DCS.

#### Using the Inputs DI3-DI5

The inputs DI3 to DI5 can be used for local motor control. DI5 is always the stop input whereas DI4 starts the motor in a forward direction and DI3 in a reverse direction (if supported by the active control function). If inching mode is enabled the stop can still be used.

#### Using the Multifunction Inputs DI0-DI2

The digital inputs DI0, DI1 and DI2 are called multifunction inputs because their function can be adapted flexibly depending to your application requirements. The following diagram shows the way the multifunction inputs work.

The three multifunction inputs operate fully independent - i.e. for each input an own delay time and function can be selected. Functions like 'test position', 'stop motor' etc. internally pass an OR gate so the UMC does not differentiate from which digital input the signal came.

If an input is configured as fault input the behaviour is different. For each input its own internal error signal is available and a fault text can be specified which is displayed on the LCD panel in the event of this error. You can thus find out what input actually triggered the fault. Faults can be auto acknowledged when the fault has been rectified.

# Universal Motor Controller

## UMC100-FBP

### Technical Description

The unchanged signal from the DI is always available for monitoring purposes (Input 1/2/3 status).

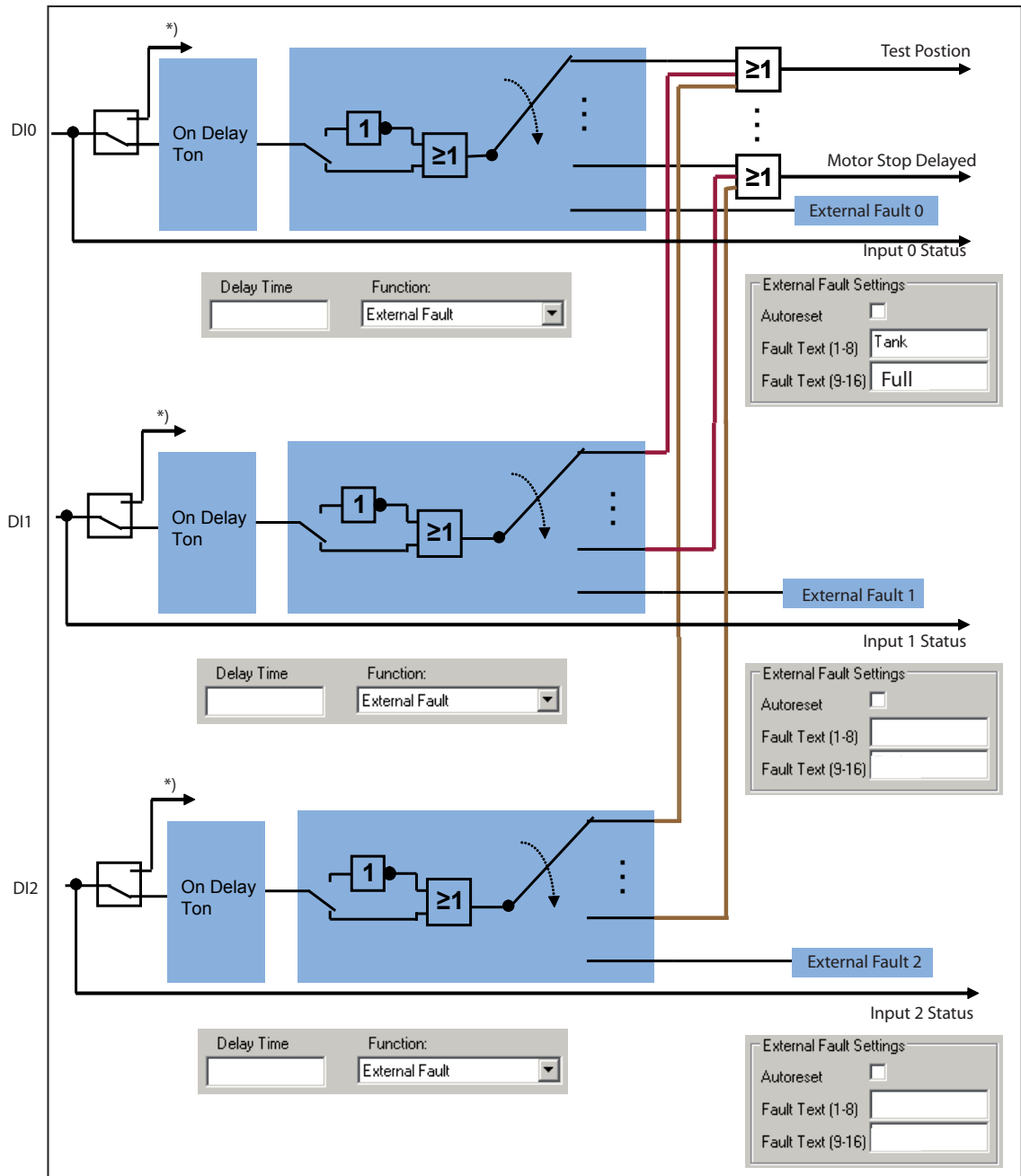

\*) If a digital input is already used for the starter function (e.g. for torque inputs in the actuator modes or for contactor checkback) they are not available anymore as multifunction inputs.

# Universal Motor Controller

## UMC100-FBP

### Technical Description

#### Sample Application for using the Multifunction Inputs

The following diagram shows how to realise a dry-pump protection application. When the motor is starting there is no pressure. It takes some time until the pressure reaches its normal value. In this example we assume that the pressure has to appear within 4 seconds, otherwise the pump can be destroyed.

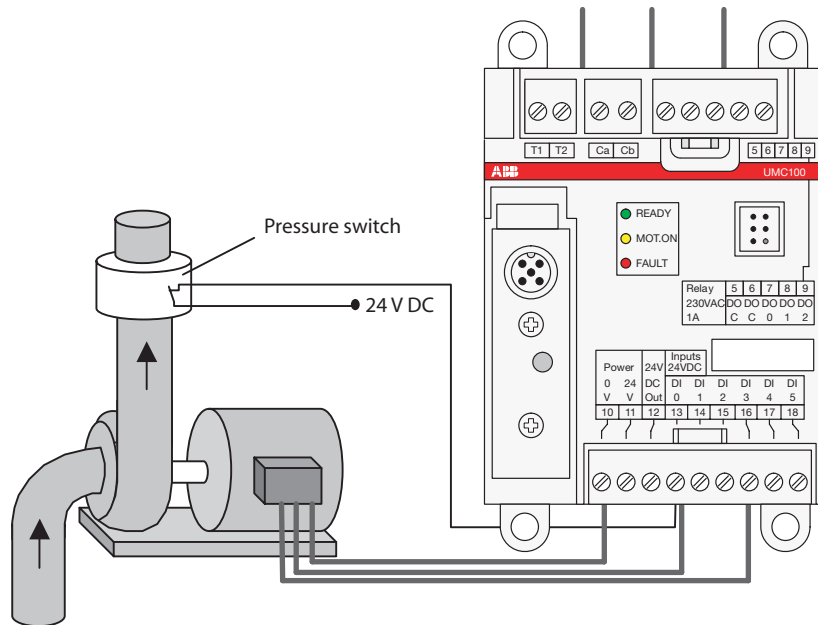

2CDC 342 022 F0209

To realize this function the multifunction input can be parameterised in the following way:

- Set the delay time to 4s
- Set the function to "Fault when motor is running"
- Define a meaningful message e.g. "Dry run"

If the pressure switch does not monitor "pressure present" within 4s (or when the pressure signal disappears for more than 4s during operation) the internal fault signal is set and the motor is stopped. The error message "Dry run" appears as a fault message.



A second example on how to use the multifunction inputs is shown in section "Starting and Stopping the Motor".

# Universal Motor Controller

## UMC100-FBP

### Technical Description

#### Control Function Transparent

The UMC100 parametrised with the control function 'Transparent' behaves like an I/O module with an integrated overload check. The outputs DO0 ... DO3 and the inputs DI0 ... DI5 are directly connected to the fieldbus and are independent of the overload status.

If a fault output (DO2 or DO3) is activated by configuration the relevant output cannot be controlled from the fieldbus anymore but is controlled by the UMC itself.

The contactor k1 can be switched on and off for example using a standard maintaining circuit (not shown).

Alternatively it can be switched on and off from the control system which uses one of the UMC relay outputs to control the motor. This option enables specific control logic to be implemented in the PLC.



The following features are not supported in this control function:

- Checkback supervision
- UMC controlled starting and stopping (bus, LCD, DI)
- Simulation and stop via multifunction inputs
- Bus fault reaction
- Voltage dip

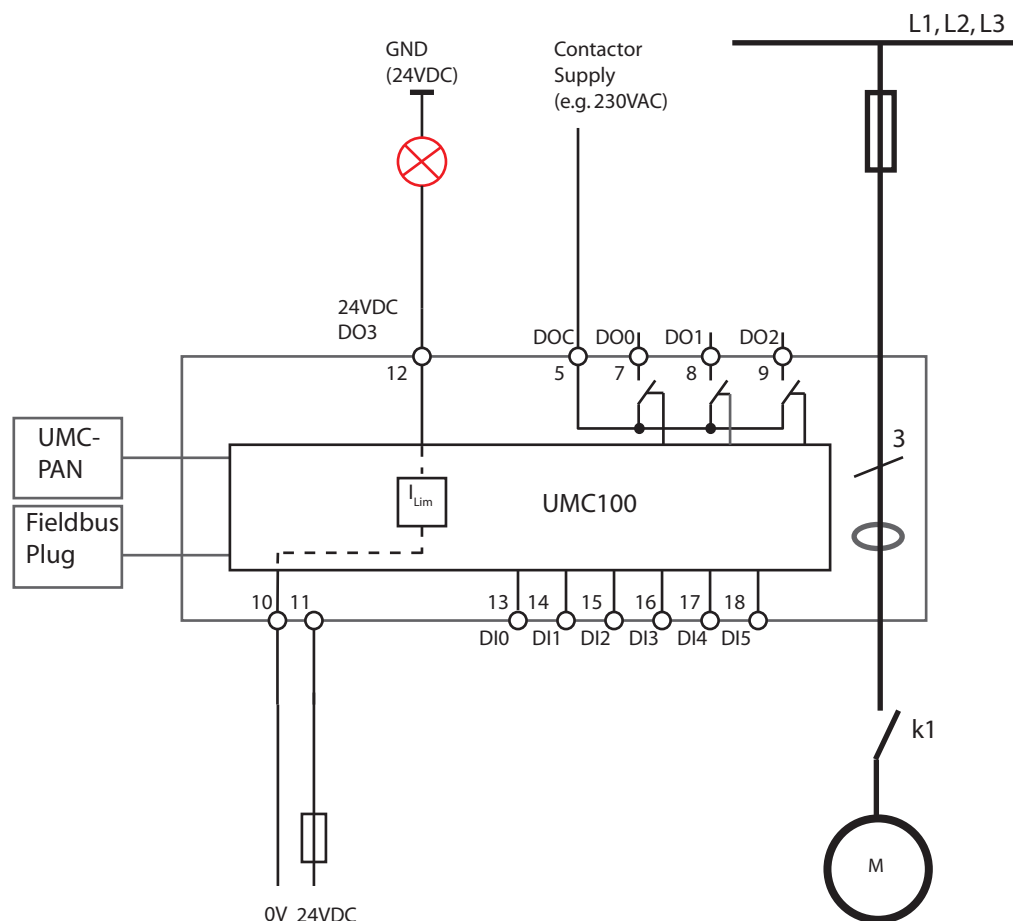

Circuit diagram of the UMC in transparent mode.

# Universal Motor Controller

## UMC100-FBP

### Technical Description

#### Monitoring Data for Transparent

Word	Byte	Bit 7	Bit 6	Bit 5	Bit 4	Bit 3	Bit 2	Bit 1	Bit 0
0	0	Summary Warning	Summary Fault	-	-	Overload warning	-	-	-
	1	UMC100 DI5	UMC100 DI4	UMC100 DI3	UMC100 DI2	UMC100 DI1	UMC100 DI0	-	-
1	2, 3	Motor Current in % of $I_g$ (0% - 800%)							
2	4, 5	Remaining data see section Parameters and Data Structures on a Fieldbus							
3	6, 7								
4	8, 9								
5	10,11								
6	12								
	13								
7	14								
	15								



The table above represents the data allocation as realised with the built-in standard applications. It may differ for customer-specific applications!

#### Command Data for Transparent

Word	Byte	Bit 7	Bit 6	Bit 5	Bit 4	Bit 3	Bit 2	Bit 1	Bit 0
0	0	-	Fault Reset	-	Prepare Emergency Start	-	-	-	-
	1	UMC100 DO2 <sup>1)</sup>	UMC100 DO1	UMC100 DO0	UMC100 24VDC Out <sup>1)</sup>	-	-	-	-
1	2	Remaining data see section Parameters and Data Structures on a Fieldbus							
	3								
2	4, 5								
3	6, 7								

<sup>1)</sup> Controlled by UMC100 if configured as fault output.



The table above represents the data allocation as realised with the built-in standard applications. It may differ for customer-specific applications!

# Universal Motor Controller

## UMC100-FBP

### Technical Description

#### Control Function Overload Relay

The UMC100 parameterised with the control function 'Overload relay' can be used to replace a standard overload relay.

The outputs DO2 ... DO3 and the inputs DI0 ... DI5 are directly connected to the fieldbus and not used from the control function.

If a fault output is activated the fault output (DO2 or 24 V DC Out DO3) cannot be controlled from the fieldbus anymore but is controlled by the UMC itself.

After powering up, contact DO0 immediately closes and contact DO1 opens.



The following features are not supported in this control function:

- Checkback supervision
- UMC controlled starting and stopping (bus, LCD, DI)
- Simulation and stop via multifunction inputs
- Bus fault reaction
- Voltage dip

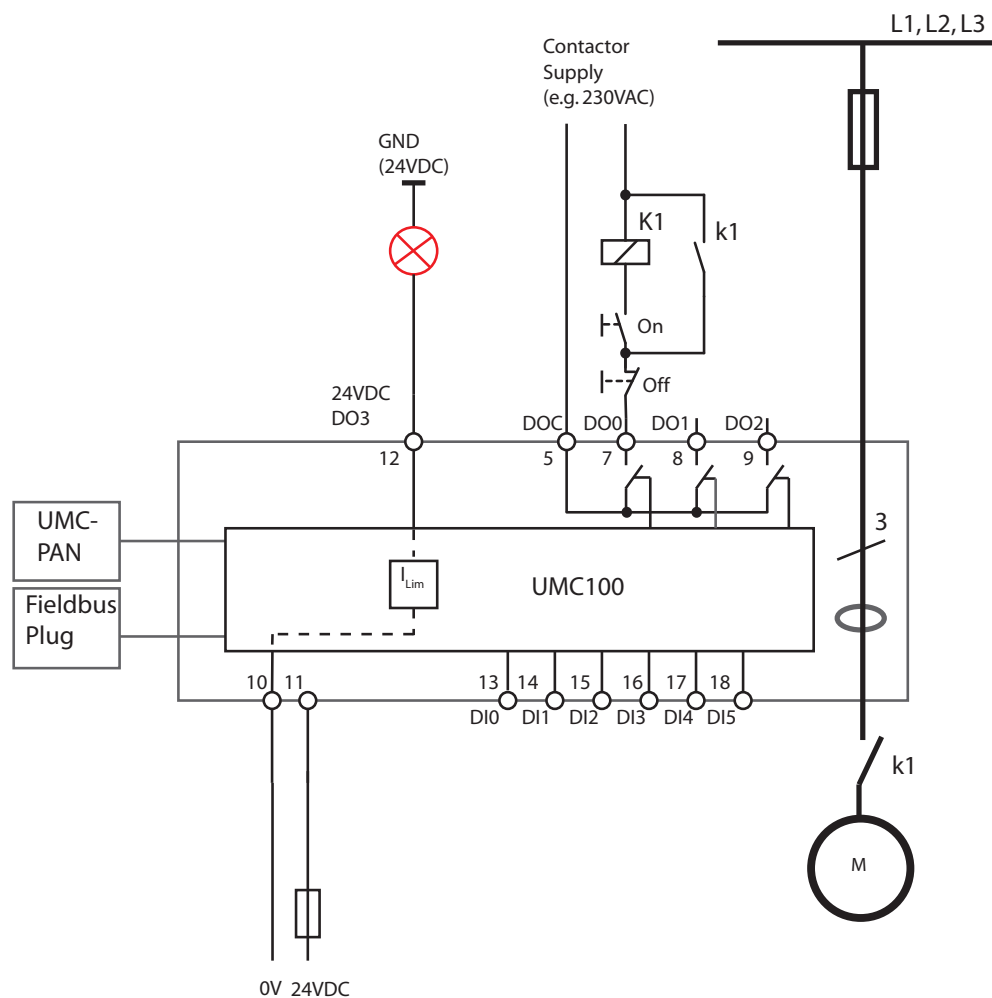

Circuit diagram of the UMC overload relay mode.

#### Fault Behaviour:

- Contact DO0 opens
- Contact DO1 closes
- The fault output DO2/DO3 is activated if configured
- The monitoring signal FAULT is sent to the fieldbus
- The red LED on the UMC is switched on
- The FAULT signal on the control panel flashes.

# Universal Motor Controller

## UMC100-FBP

### Technical Description

#### Monitoring Data for Overload Relay

Word	Byte	Bit 7	Bit 6	Bit 5	Bit 4	Bit 3	Bit 2	Bit 1	Bit 0
0	0	Summary Warning	Summary Fault	-	-	Overload warning	-	-	-
	1	UMC100 DI5	UMC100 DI4	UMC100 DI3	UMC100 DI2	UMC100 DI1	UMC100 DI0	-	-
1	2, 3	Remaining data see section Parameters and Data Structures on a Fieldbus							
2	4, 5								
3	6, 7								
4	8, 9								
5	10,11								
6	12								
	13								
7	14								
	15								



The table above represents the data allocation as realised with the built-in standard applications. It may differ for customer-specific applications!

#### Command Data Overload Relay

Word	Byte	Bit 7	Bit 6	Bit 5	Bit 4	Bit 3	Bit 2	Bit 1	Bit 0
0	0	-	Fault Reset	-	Prepare Emergency Start	-	-	-	-
	1	UMC100 DO2 <sup>1)</sup>	-	-	UMC100 24VDC Out <sup>1)</sup>	-	-	-	-
1	2	Remaining data see section Parameters and Data Structures on a Fieldbus							
	3								
2	4, 5								
3	6, 7								

<sup>1)</sup> Controlled by UMC100 if configured as fault output.



The table above represents the data allocation as realised with the built-in standard applications. It may differ for customer-specific applications!

# Universal Motor Controller

## UMC100-FBP

### Technical Description

#### Control Function Direct Starter (DOL)

Use this function in a feeder that requires a motor to start/stop in one direction of rotation.

- Relay output DO0 is used from the control function.
- Optionally DI0 can be used for contactor checkback supervision
- Optionally DI4/DI5 can be used to start/stop the motor locally
- Optionally terminals named 24VDC Out (12) or DO2 can be used as fault output

The following diagram shows the UMC wired for DOL operation. A signal lamp is connected to DO3 which serves as a fault output. The main contactor is connected to DO0. An auxiliary contact of K is used by contactor checkback monitoring. The motor can be started locally via DI4 and stopped via DI5. The remaining digital inputs can be freely used.

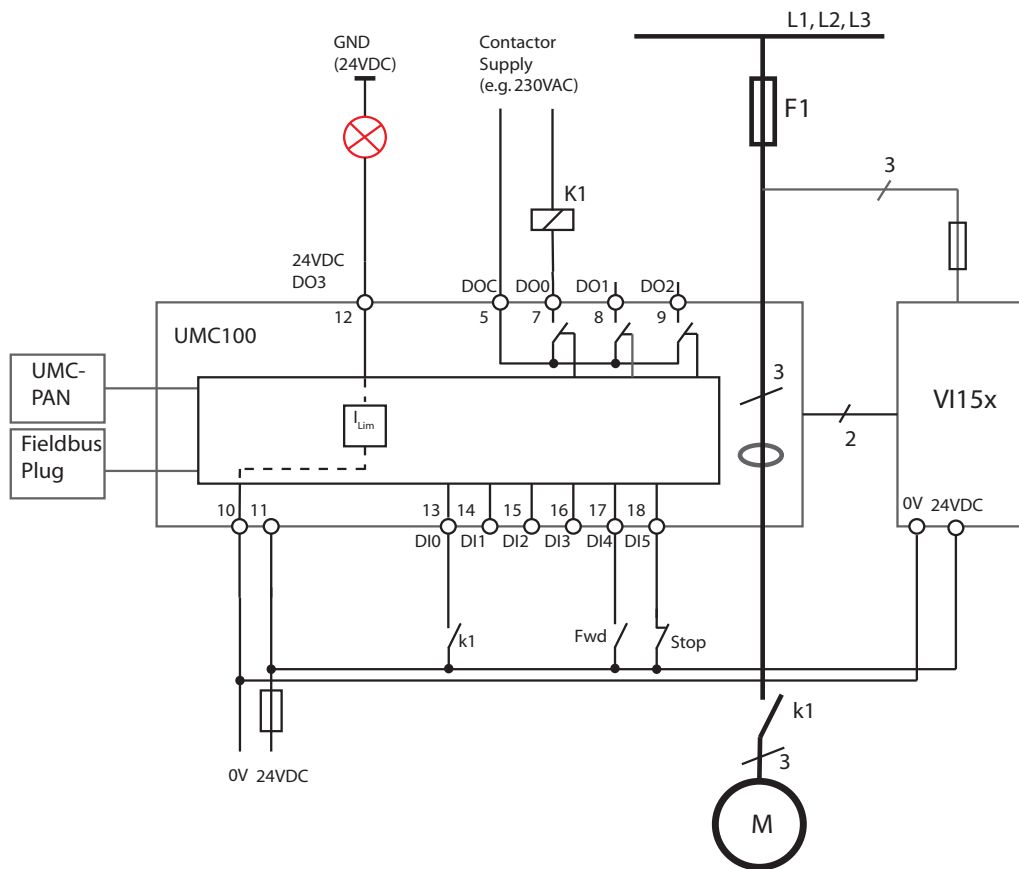

Circuit diagram of the UMC to control a motor in one direction of rotation. The checkback contact k1 is optional.

# Universal Motor Controller UMC100-FBP Technical Description

Timing Diagram for Direct Starter

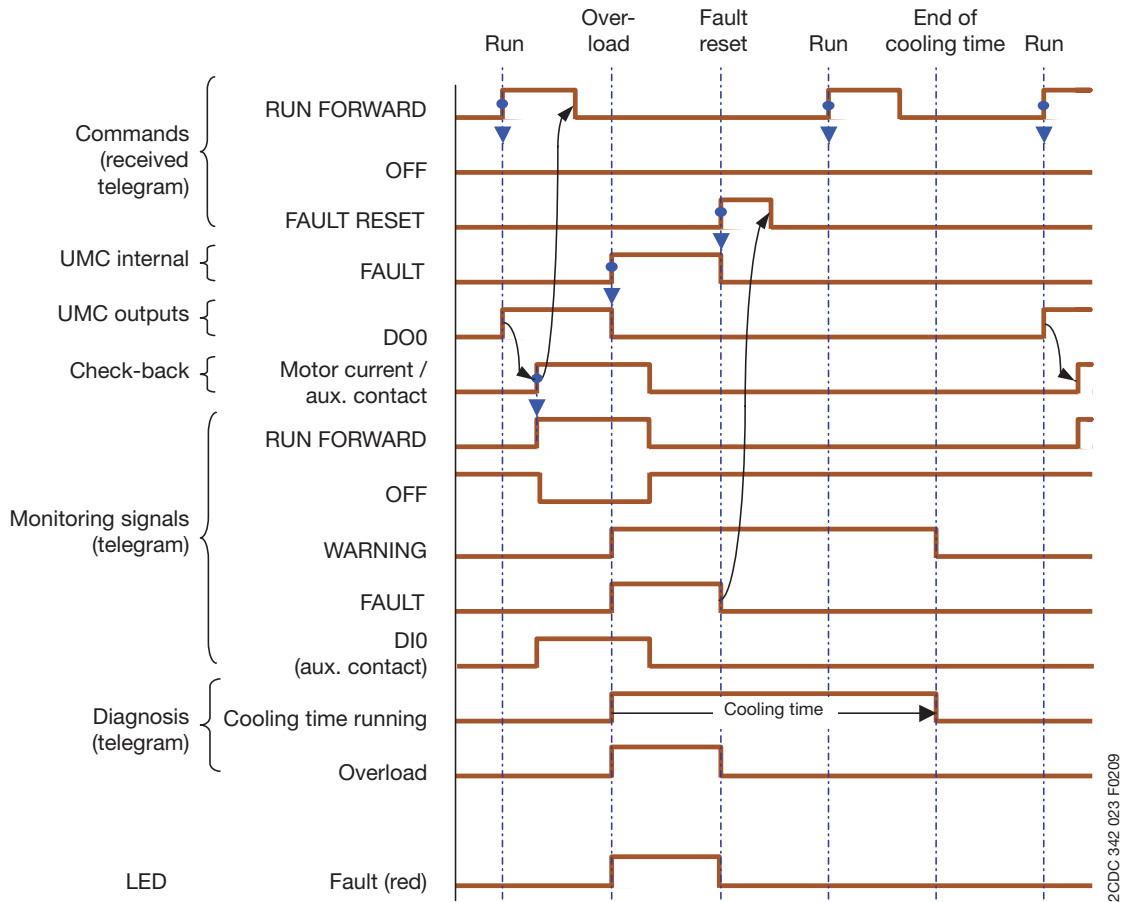

# Universal Motor Controller

## UMC100-FBP

### Technical Description

#### Monitoring Data for Direct Starter

Word	Byte	Bit 7	Bit 6	Bit 5	Bit 4	Bit 3	Bit 2	Bit 1	Bit 0
0	0	Summary Warning	Summary Fault	Local Control	-	Overload warning	Run Forward	Off	-
	1	UMC100 DI5	UMC100 DI4	UMC100 DI3	UMC100 DI2	UMC100 DI1	UMC100 DI0	-	-
1	2, 3	Remaining data see section Parameters and Data Structures on a Fieldbus							
2	4, 5								
3	6, 7								
4	8, 9								
5	10,11								
6	12								
	13								
7	14								
	15								



The table above represents the data allocation as realised with the built-in standard applications. It may differ for customer-specific applications!

#### Command Data for Direct Starter

Word	Byte	Bit 7	Bit 6	Bit 5	Bit 4	Bit 3	Bit 2	Bit 1	Bit 0
0	0	-	Fault Reset	Auto Mode	Prepare Emergency Start	-	Run Forward	Off	-
	1	UMC100 DO2 <sup>1)</sup>	UMC100 DO1	-	UMC100 24VDC Out <sup>1)</sup>	-	-	-	-
1	2	Remaining data see section Parameters and Data Structures on a Fieldbus							
	3								
2	4, 5								
3	6, 7								

<sup>1)</sup> Controlled by the UMC100 if configured as fault output



The table above represents the data allocation as realised with the built-in standard applications. It may differ for customer-specific applications!

# Universal Motor Controller

## UMC100-FBP

### Technical Description

#### Control Function Reversing Starter (REV)

Use this function in a feeder that requires a motor to start/stop in two direction of rotation (forwards/backwards).

- Relay output DO0 is used by the control function to start the motor in a forward direction.
- Relay output DO1 is used from the control function to start the motor in a reverse direction.
- Optionally DI0 can be used for contactor checkback supervision
- Optionally DI3 / DI4 can be used to start the motor and DI5 to stop the motor
- Optionally terminals named 24VDC Out (12) or DO2 can be used as a fault output

The following diagram shows the UMC wired for REV operation. A signal lamp is connected to DO3 which serves as a fault output. The main contactor is connected to DO0 and DO1. Two auxiliary contacts k1 and k2 are used for contactor checkback monitoring. The motor can be started locally via DI3/DI4 and stopped via DI5. The remaining digital inputs can be freely used.

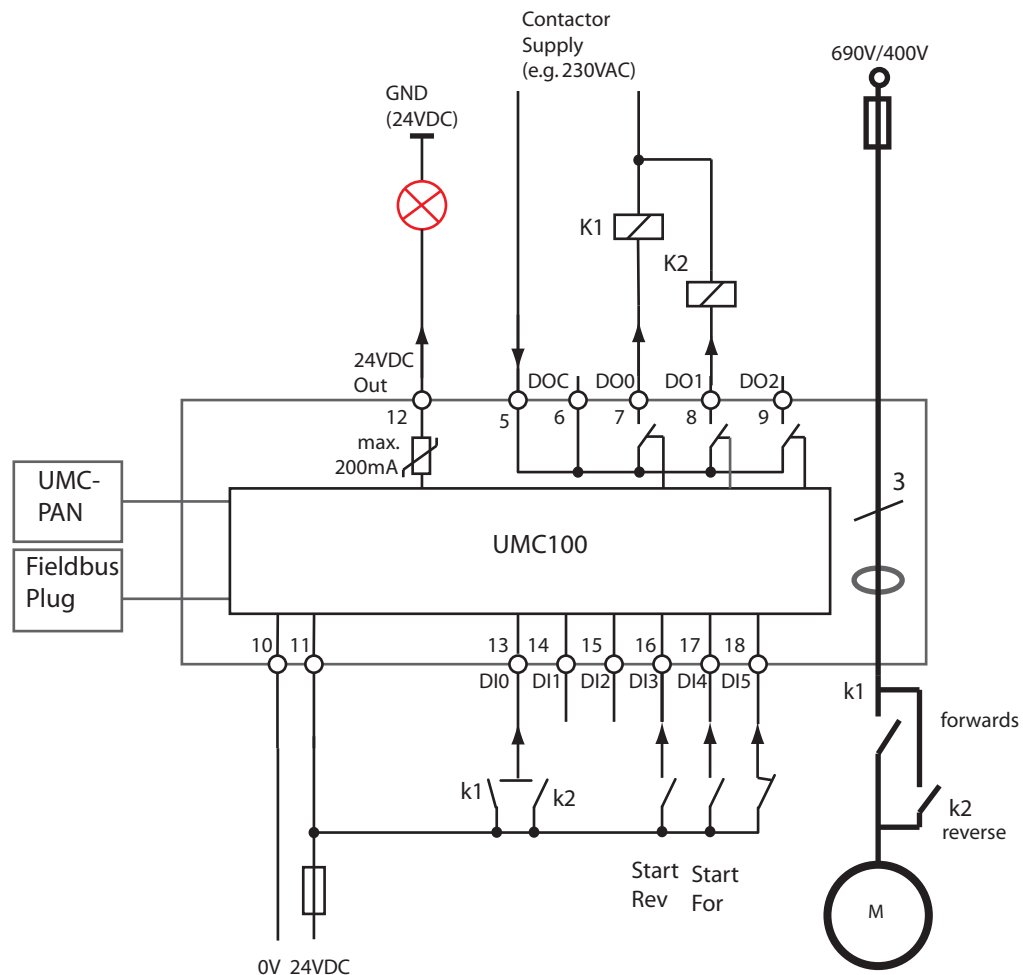

Circuit diagram of the UMC for controlling a motor in two directions of rotation. The checkback contacts k1/k2 are optional.

# Universal Motor Controller UMC100-FBP Technical Description

## Timing Diagram for Changing Direction

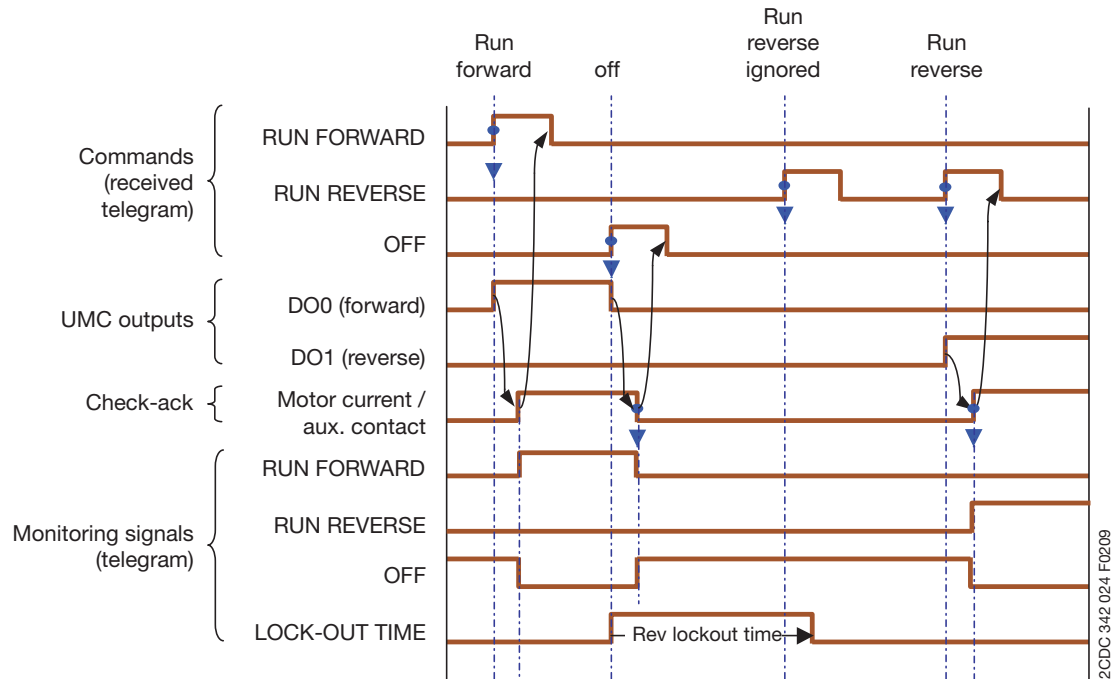

### Remark:

- Opposite direction only possible after OFF and after the reverse lock-out time has elapsed.
- Restart in the same direction without consideration of the Reverse lock-out time.

### Related parameters

- Reverse Lockout Time

# Universal Motor Controller

## UMC100-FBP

### Technical Description

#### Monitoring Data for Reversing Starter

Word	Byte	Bit 7	Bit 6	Bit 5	Bit 4	Bit 3	Bit 2	Bit 1	Bit 0
0	0	Summary Warning	Summary Fault	Local Control	Reverse Lockout Time	Overload warning	Run Forward	Off	Run Reverse
	1	UMC100 DI5	UMC100 DI4	UMC100 DI3	UMC100 DI2	UMC100 DI1	UMC100 DI0	-	-
1	2, 3	Remaining data see section Parameters and Data Structures on a Fieldbus							
2	4, 5								
3	6, 7								
4	8, 9								
5	10,11								
6	12								
	13								
7	14								
	15								



The table above represents the data allocation as realised with the built-in standard applications. It may differ for customer-specific applications!

#### Command Data for Reversing Starter

Word	Byte	Bit 7	Bit 6	Bit 5	Bit 4	Bit 3	Bit 2	Bit 1	Bit 0
0	0	-	Fault Reset	Auto Mode	Prepare Emergency Start	-	Run Forward	Off	Run Reverse
	1	UMC100 DO2 <sup>1)</sup>	-	-	UMC100 24VDC Out <sup>1)</sup>	-	-	-	-
1	2	Remaining data see section Parameters and Data Structures on a Fieldbus							
	3								
2	4, 5								
3	6, 7								

<sup>1)</sup> Controlled by the UMC100 if configured as fault output.



The table above represents the data allocation as realised with the built-in standard applications. It may differ for customer-specific applications!

# Universal Motor Controller

## UMC100-FBP

### Technical Description

#### Control Function Star-Delta Starter

Use this function in a feeder that requires to start/stop a motor in one direction of rotation including the time- or current-controlled transition from star to delta.

- Relay output DO0 is used by the control function to control the star contactor
- Relay output DO1 is used by the control function to control the delta contactor
- Relay output DO2 is used by the control function to control the main contactor. It cannot be used as fault output. Use the 24VDC output DO3 if a fault output is required.
- Optionally DI0 can be used for contactor checkback supervision
- Optionally DI4 can be used to start the motor and DI5 to stop it
- Optionally terminal named 24VDC Out (12) can be used as a fault output



- The voltage dip function is not supported in this control function.
- Adjust parameter YD changeover mode
- Adjust parameter YD starting time. The switch over from Star (Y) to Delta (D) takes place earliest after 1 second. The parameter *YD starting time* must therefore be set to at least 1 second.

The following diagram shows the UMC wired for star-delta operation. A signal lamp is connected to DO3 which serves as a fault output. The main contactor is connected to DO0 to DO2. Three auxiliary contacts are used for contactor checkback monitoring. The motor can be started locally via DI4 and stopped via DI5. The remaining digital inputs can be freely used.

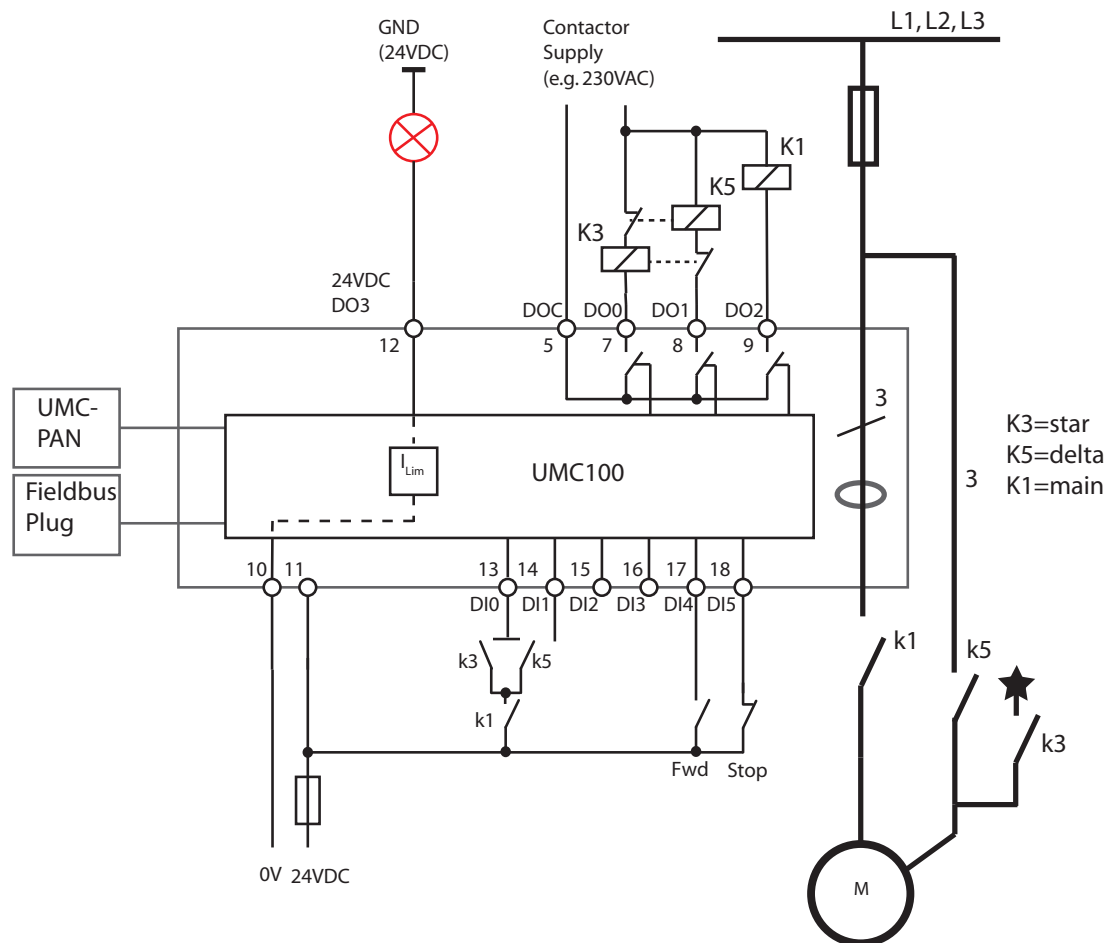

Circuit diagram of the UMC for controlling a motor in star-delta mode. The checkback contacts k3/K5 and K1 are optional.

# Universal Motor Controller UMC100-FBP Technical Description

Timing Diagram for Star-Delta Starter

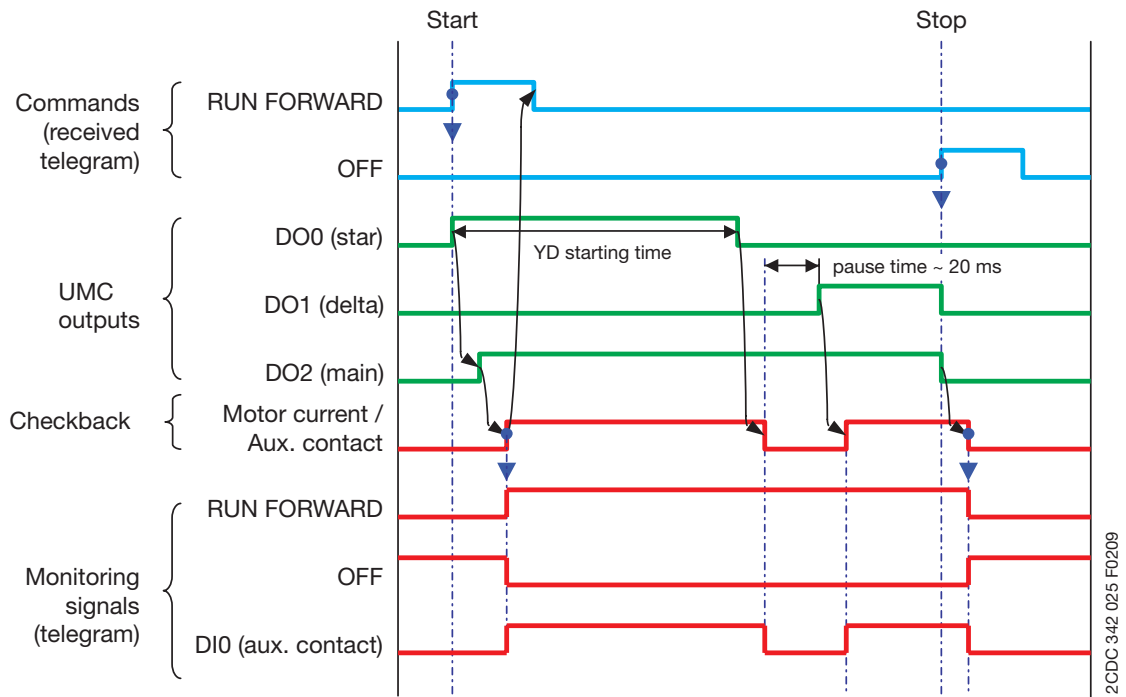

# Universal Motor Controller

## UMC100-FBP

### Technical Description

#### Monitoring Data for Star-Delta Starter

Word	Byte	Bit 7	Bit 6	Bit 5	Bit 4	Bit 3	Bit 2	Bit 1	Bit 0
0	0	Summary Warning	Summary Fault	Local Control	-	Overload warning	Run Forward	Off	-
	1	UMC100 DI5	UMC100 DI4	UMC100 DI3	UMC100 DI2	UMC100 DI1	UMC100 DI0	-	-
1	2, 3	Motor Current in % of $I_g$ (0% - 800%)							
2	4, 5	Remaining data see section Parameters and Data Structures on a Fieldbus							
3	6, 7								
4	8, 9								
5	10,11								
6	12								
	13								
7	14								
	15								



The table above represents the data allocation as realised with the built-in standard applications. It may differ for customer-specific applications!

#### Command Data for Star-Delta Starter

Word	Byte	Bit 7	Bit 6	Bit 5	Bit 4	Bit 3	Bit 2	Bit 1	Bit 0
0	0	-	Fault Reset	Auto Mode	Prepare Emergency Start	-	Run Forward	Off	-
	1	-	-	-	UMC100 24VDC Out <sup>1)</sup>	-	-	-	-
1	2	Remaining data see section Parameters and Data Structures on a Fieldbus							
	3								
2	4, 5								
3	6, 7								

<sup>1)</sup> Controlled by the UMC100 if configured as fault output.



The table above represents the data allocation as realised with the built-in standard applications. It may differ for customer-specific applications!



# Universal Motor Controller UMC100-FBP Technical Description

## Dahlander Motor

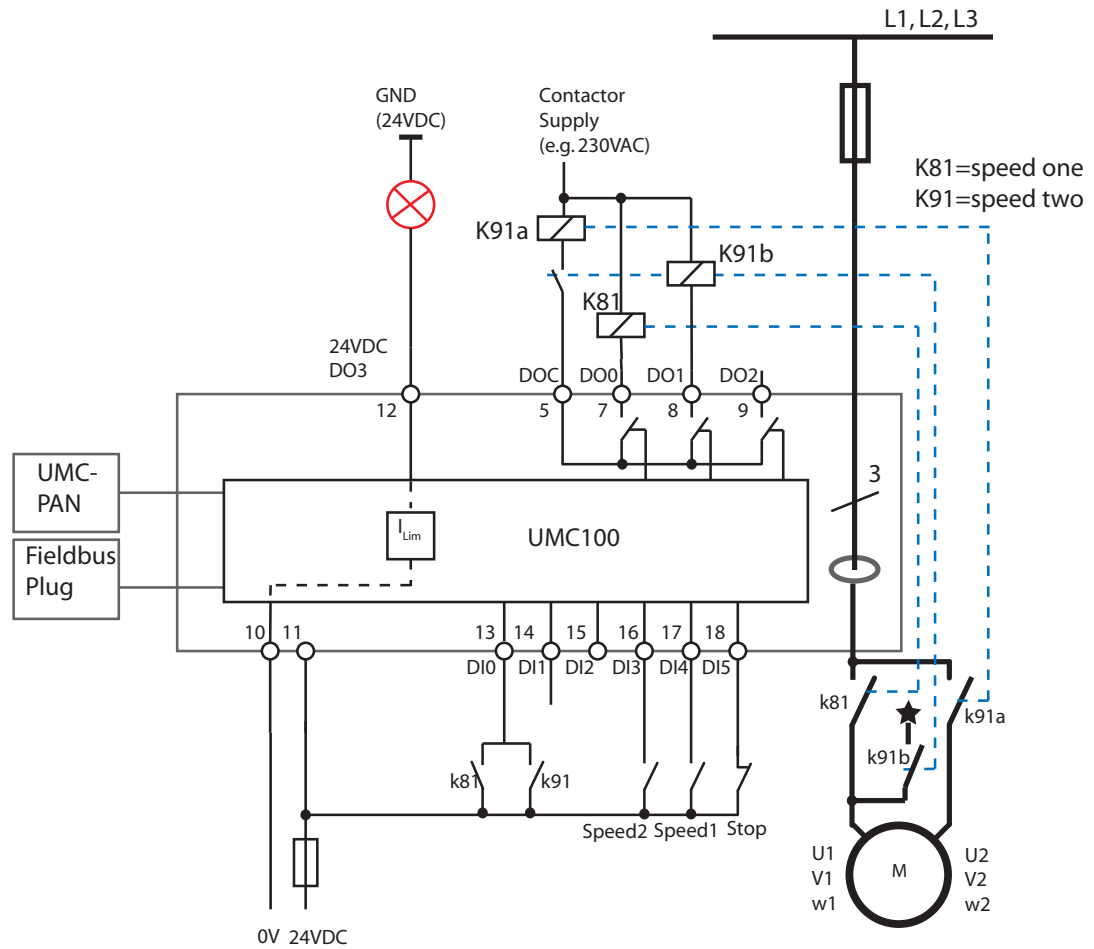

Circuit diagram of the UMC for controlling dahlander motors. The checkback contacts k81/k91 are optional.

## Timing Diagram for Pole-Changing Starter

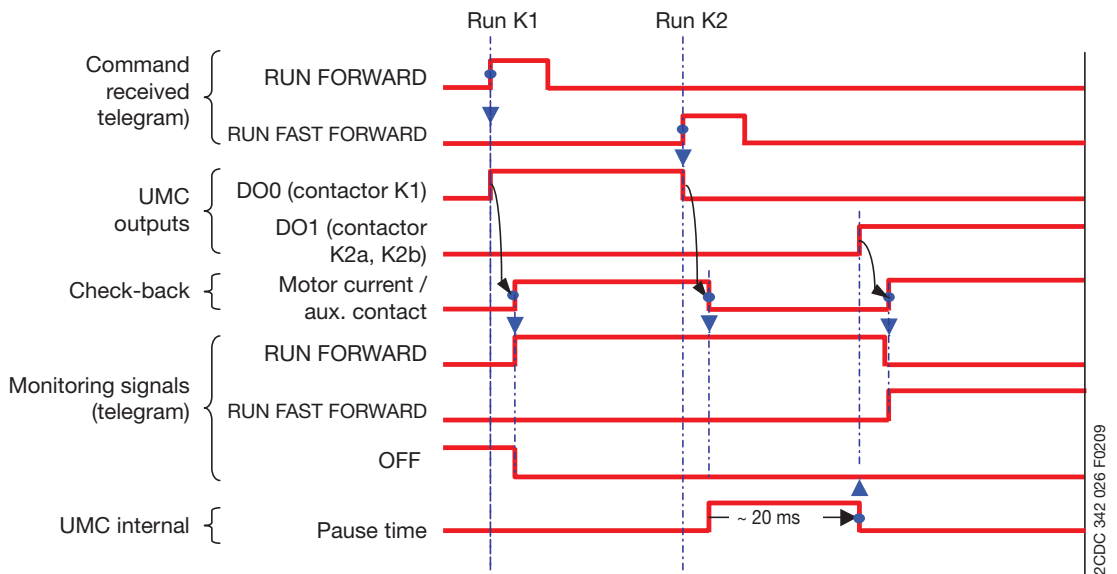

2CDC 342 026 F0209

# Universal Motor Controller

## UMC100-FBP

### Technical Description

#### Monitoring Data for Pole-Changing Starter

Word	Byte	Bit 7	Bit 6	Bit 5	Bit 4	Bit 3	Bit 2	Bit 1	Bit 0
0	0	Summary Warning	Summary Fault	Local Control	-	Overload warning	Run Forward	Off	-
	1	UMC100 DI5	UMC100 DI4	UMC100 DI3	UMC100 DI2	UMC100 DI1	UMC100 DI0	Run Fast Forward	-
1	2, 3	Motor Current in % of $I_g$ (0% - 800%)							
2	4, 5	Remaining data see section Parameters and Data Structures on a Fieldbus							
3	6, 7								
4	8, 9								
5	10,11								
6	12								
	13								
7	14								
	15								



The table above represents the data allocation as realised with the built-in standard applications. It may differ for customer-specific applications!

#### Command Data for Pole-Changing Starter

Word	Byte	Bit 7	Bit 6	Bit 5	Bit 4	Bit 3	Bit 2	Bit 1	Bit 0
0	0	-	Fault Reset	Auto Mode	Prepare Emergency Start	-	Run Forward	Off	-
	1	UMC100 DO2 <sup>1)</sup>	-	-	UMC100 24VDC Out <sup>1)</sup>	-	-	Run Fast Forward	-
1	2	Remaining data see section Parameters and Data Structures on a Fieldbus							
	3								
2	4, 5								
3	6, 7								

<sup>1)</sup> Controlled by UMC100 if configured as fault output.



The table above represents the data allocation as realised with the built-in standard applications. It may differ for customer-specific applications!

# Universal Motor Controller

## UMC100-FBP

### Technical Description

#### Control Function Actuator 1 - 4

Use this function in a feeder that requires the operation of an actuator that opens/closes e.g. a valve. Please note that the actuator operation mode is not able to keep a valve at a certain setpoint.



The voltage dip function is not supported and checkback via DIO is not supported in these control functions.

Set the following parameters as listed here:

- Inv DI start input = No
- Inv DI stop input = No
- Inching DI start input (Jog) = Yes
- Multifunction 0/1 = Off
- Checkback: Current or Simulation (test purposes only)
- Adjust Time Limit Actuator

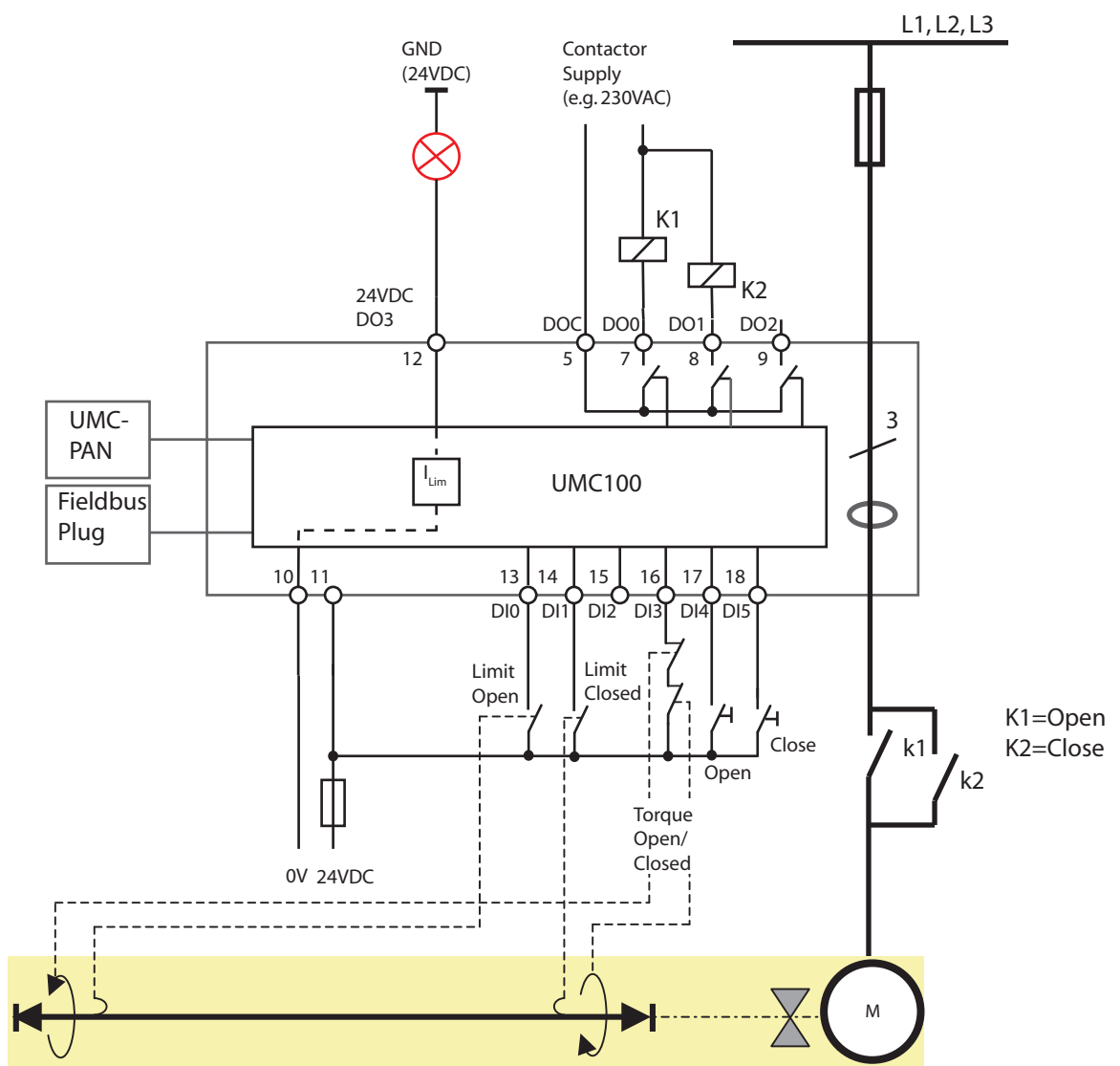

Control function = Actuator 2 (Basic circuit)

The control functions Actuator 1, 2, 3 and 4 provide different use of and reaction to the limit switches "Closed" and "Open" as well as the torque switches. The switches must be connected in a predefined manner to DI0, DI1 and DI3.

Optionally terminals named 24VDC Out (12) or DO2 can be used as a fault output

# Universal Motor Controller UMC100-FBP Technical Description

Overview:

Control function	Open <-> Closed			
	Torque open	Limit open	Limit closed	Torque closed
Actuator 1	-	Stop	Stop	-
Actuator 2	Stop	Prepare	Prepare	Stop
Actuator 3	-	Stop	Prepare	Stop
Actuator 4	Stop	Prepare	Stop	-

## Actuator 1

Open and Closed position via limit switches

Usage with limit switches

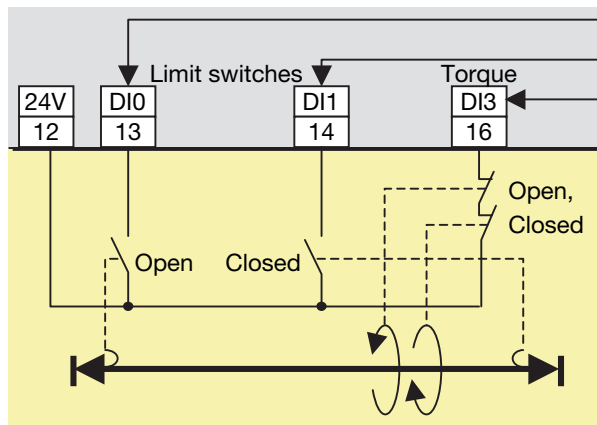

DI0: Motor off, start only in Closed direction

DI1: Motor off, start only in Open direction

DI3: Fault: motor stops

Remark:

- Torque signals are not necessary but can be used for surveillance.
- After switching off the motor continues to run for some milliseconds due to its rotating mass. Adjustment of the Closed and Open limit switches is necessary to achieve the correct end positions.

2CDC 342 020 F0205

Usage without torque switches

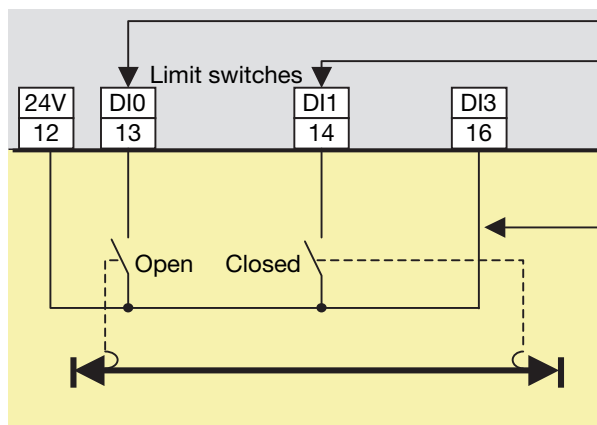

DI0: Motor off, start only in Close direction

DI1: Motor off, start only in Open direction

Remark:

Connection if torque contacts are not available

2CDC 342 021 F0205

# Universal Motor Controller

## UMC100-FBP

### Technical Description

#### Actuator 2

Open and Closed position via torque and limit switches

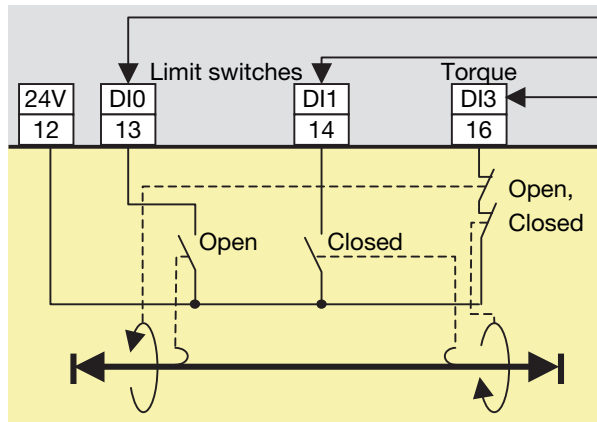

2CDC 342 020 F0206

\*) Start is only possible in the opposite direction after resetting the fault. The torque signal has to disappear within 0.5 s otherwise a fault is generated again.

- DI0: Preparation for Open limit motor off
- DI1: Preparation for Closed limit motor off
- DI3:
  - Motor off, start only in opposite direction
  - Fault if not prepared\*

Remark:

- The limit switches Open or Closed prepare the stop. Torque Open or Closed stops the motor. Starting is only possible in the opposite direction.
- The single torque signals in the telegram - torque Open or torque Closed - are calculated based on the direction of movement before the stop.
- If after powering up a torque signal is detected and neither an Open nor a Closed limit is present it is presumed that the torque occurred during closing. The start is possible only after fault acknowledgement and only in the opposite direction.

#### Actuator 3

Open position via limit switch only, Closed position via torque and limit switches

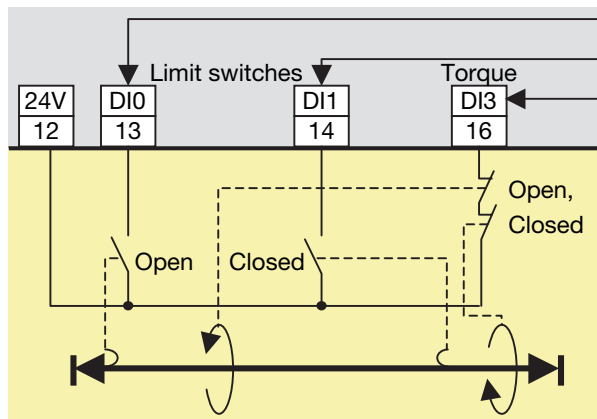

2CDC 342 021 F0206

- DI0: Motor off, start only in Closed direction
- DI1: Preparation for Closed limit off
- DI3:

- Motor off if prepared for Closed limit motor off, start only in Open direction
- Fault if not prepared\*

Remark:

- The limit switch Open prepares the stop. Torque Open stops the motor. Starting is only possible in the opposite direction
- The single torque signals in the telegram - torque open or torque closed - are calculated based on the direction of movement before the stop.

# Universal Motor Controller

## UMC100-FBP

### Technical Description

#### Actuator 4

Open position via torque and limit switches, Closed position via limit switch only

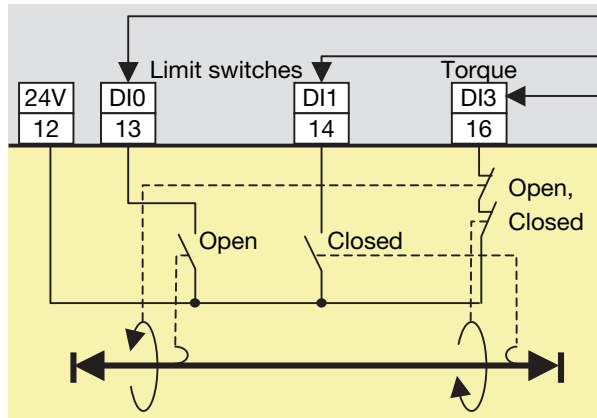

DI0: Preparation for Open limit motor off

DI1: Motor off, start only in Open direction

DI3:

- Motor off if prepared for Open off, start only in Closed direction
- Fault if not prepared or if during closing

Remark:

- The limit switch Closed prepares the stop. Torque closed stops the motor. Starting is only possible in the opposite direction
- The single torque signals in the telegram - torque Open or torque Closed - are calculated based on the direction of movement before the stop.

2 CDC 342 022 F0206

#### Definitions and monitoring signals particular to the control functions Actuator 1,2,3 and 4

- Input signals: Open and Closed inputs are active signals, torque input is a closed loop signal.
- The two torque signals are connected in series. The discrete torque signal is created based on the previous direction of movement.

Remark:

If DI2 is not needed as fault input it can be connected to the link between the torque contacts to find out which torque signal is active.

- Run-time Open <-> Closed: The Run-time limit (= Star-delta starting time) must be changed and should be set according to actuator data. Setting the Run-time limit = 1 s disables the supervision.
- Starting from Open or Closed: The limit switch has to open within the start monitoring time of 3 s. Exceeding the time results in the fault signal Open limit switch 1 -> 0 not occurring within 3 s after the Closed command. The start monitoring time can be extended.
- A faulty torque signal in the intermediate position sets the internal fault signal. The motor is stopped and can be started again
  - after fault reset via fieldbus or other - AND -
  - only in the opposite direction (previous direction is blocked).

After starting the torque signal must disappear within 0.5 s. Otherwise the internal fault signal is set again. A fault reset and start in the opposite direction can be repeated as often as desired.

- If after powering up a torque signal (0-signal) is present and neither an Open nor a Closed signal is present it is presumed that the torque occurred during closing. The motor can be started:
  - after fault reset via fieldbus or other - AND -
  - only in the Open direction

# Universal Motor Controller

## UMC100-FBP

### Technical Description

#### Monitoring Data for Actuator 1 - 4

Word	Byte	Bit 7	Bit 6	Bit 5	Bit 4	Bit 3	Bit 2	Bit 1	Bit 0
0	0	Summary Warning	Summary Fault	Local Control	Reverse Lockout Time	Overload warning	Opening	Off	Closing
	1	UMC100 DI5	UMC100 DI4	UMC100 DI3	UMC100 DI2	UMC100 DI1	UMC100 DI0	-	-
1	2, 3	Motor Current in % of $I_g$ (0% - 800%)							
2	4, 5	Remaining data see section Parameters and Data Structures on a Fieldbus							
3	6, 7								
4	8, 9								
5	10,11								
6	12								
	13								
7	14								
	15								



The table above represents the data allocation as realised with the built-in standard applications. It may differ for customer-specific applications!

#### Command Data for Actuator 1 - 4

Word	Byte	Bit 7	Bit 6	Bit 5	Bit 4	Bit 3	Bit 2	Bit 1	Bit 0
0	0	-	Fault Reset	Auto Mode	Prepare Emergency Start	-	Opening	Off	Closing
	1	UMC100 DO2 <sup>1)</sup>	-	-	UMC100 24VDC Out <sup>1)</sup>	-	-	-	-
1	2	Remaining data see section Parameters and Data Structures on a Fieldbus							
	3								
2	4, 5								
3	6, 7								

<sup>1)</sup> Controlled by UMC100 if configured as fault output.



The table above represents the data allocation as realised with the built-in standard applications. It may differ for customer-specific applications!

---

**Universal Motor Controller  
UMC100-FBP  
Technical Description**

---

---

# Universal Motor Controller

## UMC100-FBP

### Technical Description

---

## 6 Configuring the Fieldbus Communication

The UMC can be integrated into different fieldbus networks with the help of a FieldBusPlug. FieldBusPlugs exist presently for PROFIBUS (PDP22 / PDQ22), DeviceNet(DNP21), Modbus (MRP21) and CANopen (COP21).

Since the fieldbuses and the various fieldbus master configuration tools are very different no common integration procedure can be described here. In general the following generic steps are usually necessary:

1. Make the UMC known to the tool e.g. by importing the device description file (GSD, EDS)
2. Create a network and insert nodes like the UMC as required
3. Set the UMC parameters according to your needs (if parameterisation from within the system is required)
4. Make the I/O signals available in your programming tool (e.g. a IEC61131 based tool)

To use the UMC in a fieldbus network the following parameters should be considered.

### Setting the Bus Address

The bus address can be adjusted with the help of the UMC LCD panel. The UMC allows an address to be set between 000 and 255. But there are different limitations depending on the fieldbus in use. Setting the address to 255 means that the UMC will take over the address from a connected FieldBusPlug.

- PROFIBUS: 2 ...125
- DeviceNet: 2-64
- Modbus: With the bus address you also select the baud rate used by the MRP21 FieldBusPlug. Check the MRP21 manual about the available options.
- CANopen: 1-127



Ensure that the chosen bus address is not used twice. If an address is used twice the whole bus line might go out of operation.

Related Parameter: *Bus Address*

### Address Check when using UMC in Motor Control Centres

If the UMC is used in MCCs the address check can be enabled. This ensures that the bus address in the FieldBusPlug and the UMC must match before the bus communication can start. This ensures that in the event of an unintentional permutation of a drawer the bus address stays in place and does not move with the drawer.

A precondition for this function is the separation of FieldBusPlug and UMC. In MCCs the FieldBusPlug is usually mounted in the cable chamber whereas the UMC is mounted in the withdrawable unit. This means that even if the withdrawable is removed the FieldBusPlug stays active, keeps the bus address and can send an error message (missing device) to the control system.

The following cases can occur:

1. Neither the UMC100 nor the FieldBusPlug contains a valid address (i.e. 255): The UMC does not start to communicate.
2. Only the UMC100 contains a valid address (i.e. 255): The FieldBusPlug receives the address and saves it. Then the bus communication starts automatically.
3. Only the FieldBusPlug contains a valid address (e.g. a new spare UMC is connected which has 255 as address). The UMC gets the address from the FieldBusPlug and saves it. Then the communication starts.
4. The UMC100-FBP and the FieldBusPlug contain the same address: Operation and communication starts.
5. The UMC100-FBP and the FieldBusPlug contain different addresses (e.g. unintentional permutation when installing a drawer): The behaviour of the UMC100-FBP depends on the setting of the parameter Address check.

---

# Universal Motor Controller

## UMC100-FBP

### Technical Description

---

Case 5a: Address check = Off (= 0) (default)

The FieldBusPlug stores the address received from the UMC100 and communication starts.

Case 5b: Address check = On (1)

- The communication does not start. In the LCD control panel an address fault is displayed



- To start the bus communication the correct address (i.e. the one from the FieldbusPlug must be selected in the UMC100
- Enter the fault menu with the left hot-key (Addr)

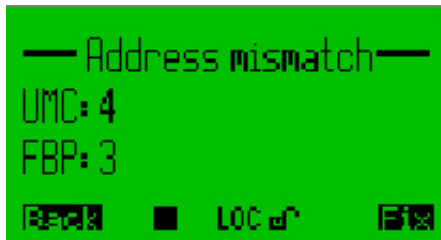

- Click "Fix" (right hot-key) to select the fieldbus plug bus address
- After saving the corrected bus address the communication starts immediately
- Both the FieldBusPlug and the UMC100-FBP store the adjusted address.

Related Parameter: *Address Check*

#### Defining the Bus Fault Reaction

Depending on the application the UMC is used in you might configure the reaction to a bus fault in a different way. The bus fault reaction can be set the following way:

- Retain the present state (either running or stopped)
- Stop the motor immediately
- Start the motor in a forward direction (if actually in stop mode). If it is already running in a reverse or a forward direction the motor keeps running.
- Start the motor in a reverse direction (if actually in stop mode). If it is already running in a reverse or a forward direction the motor keeps running.

Relevant parameter: *Bus Fault Reaction*

---

# Universal Motor Controller

## UMC100-FBP

### Technical Description

---

#### Ignore Block Parameters

Block parameters can be used to parameterise a device from within the PROFIBUS master using the GSD file. The PROFIBUS master then sends the parameters in one block (this where the name came from) to the device. The block parameters are sent under certain conditions:

- Bus master start-up
- Device start-up
- During normal operation in case of parameter changes

If the UMC shall be parameterized via LCD panel or using the PBDTM the block parameters should not be sent. As it is not possible to stop the bus master from sending the block parameters the FieldBusPlug can be configured to stop forwarding these parameters to the UMC (i.e. ignore them). To do so set parameter "Ignore Block Parameter" to "Ignore".



A typical customer error message if this parameter was not set is as follows: *"We set up everything correctly and the plant worked for weeks without problems. But then suddenly the UMC lost its parameters."*

What happened: The UMC was configured e.g. via LCD panel during commissioning. Then weeks later the bus master or controller was restarted for whatever reason and therefore sent the default UMC block parameters as they were never set.

If you are unsure if the parameter was set correctly you can also lock the parameters in the UMC. Then no parameter changes are possible anymore until the lock is reset. If locked the small "lock" icon  is set in the LCD display.

Relevant parameter:

*Ignore Block Parameters.*

---

**Universal Motor Controller**  
**UMC100-FBP**  
**Technical Description**

---

# Universal Motor Controller

## UMC100-FBP

### Technical Description

## 7 Using Expansion Modules

In this chapter you learn how to use the UMC expansion modules. Expansion modules allow you to increase the number of usable inputs and outputs. For information on how to connect the IO modules to the UMC read the 'Installation' chapter. The IO module's status messages are described in the chapter 'Error Handling, Maintenance and Service'.

### Using a Digital IO Module (DX111/122)

To activate a digital IO module set parameter *DX1xx Enabled* to *On*. If a module is enabled the UMC monitors the presence of the module and creates by default a fault in the event that the module is missing (-> parameter 'Missing Module Reaction').

### Using the Digital Inputs

By default all eight digital inputs are available in the fieldbus monitoring telegram. They can thus be directly used in the PLC/DCS application.

For inputs 1DI0 to 2DI5 the following additional options exist:

- Each input can separately trigger a fault or warning with a unique error code and error message that is shown on the UMC's LCD panel.
- A fault can be automatically cleared when the cause of the fault is rectified.
- Each input can optionally be delayed. (see parameter DX1xx DI delay for details)

The following figure shows the internal data flow of the inputs 1DI0 - 2DI5.

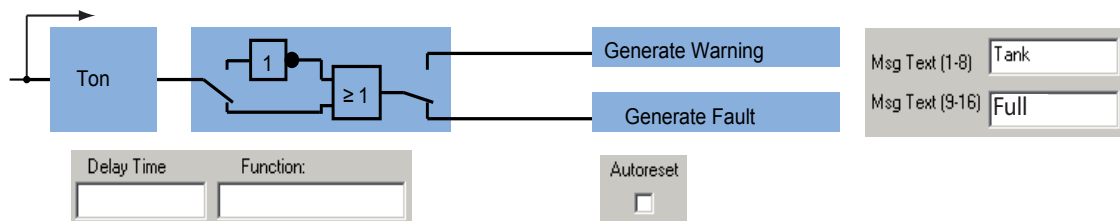

▲ Functionality of the six digital inputs 1DI0 - 2DI5 of the DX111 and DX122 modules.



Internally the digital inputs of the DX1xx module are connected to a function block called 'AuxFaultWarn' with six inputs called Aux1 to Aux6. The following table shows which IO module input relates to which parameter set:

DX1xx input	Parameters	DX1xx Input	Parameters
1DI0	Aux. Inp. 1	1DI4	Aux. Inp. 5
1DI1	Aux. Inp. 2	2DI5	Aux. Inp. 6
1DI2	Aux. Inp. 3	-	-
1DI3	Aux. Inp. 4	-	-

### Using the Relay Outputs

The 4 relay outputs are connected to the fieldbus command telegram and can be freely used by the control system. By default they are not used by the UMC in any way. See the fieldbus command telegram for the relevant bit positions.



The inputs and outputs of the modules DX122 and DX111 can be freely used in the Custom Application Editor. Consult the editor's manual if you plan to use the inputs or outputs directly in the UMC.

# Universal Motor Controller

## UMC100-FBP

### Technical Description

#### Using the Analogue Output

The analogue output can be used to drive an analogue instrument to e.g. display the motor current. It can work in the following modes: 4-20mA, 0-20mA, 0-10V

Relevant Module Parameters:

<ul style="list-style-type: none"> <li>• <i>DX1xx Enabled</i></li> <li>• <i>Aux. Inp 1 - 6 Delay</i></li> <li>• <i>DX1xx DI Delay (Delay for all inputs)</i></li> <li>• <i>Analog Out0 Type</i></li> <li>• <i>Analog Out0 Error Reaction</i></li> </ul>	<ul style="list-style-type: none"> <li>• <i>Aux. Inp 1 - 6 Acknowledge Mode</i></li> <li>• <i>Aux. Inp 1 - 6 Reaction</i></li> <li>• <i>Aux. Inp 1 -6 Message Line 1 / Line 2</i></li> <li>• <i>Missing Module Reaction</i></li> </ul>
---------------------------------------------------------------------------------------------------------------------------------------------------------------------------------------------------------------------------------------------------------	----------------------------------------------------------------------------------------------------------------------------------------------------------------------------------------------------------------------------------------

#### Using a Voltage Module (VI150/155)

##### Activating a Voltage Module (VI150/155)

To activate the voltage module set parameter *VI15x Enabled* to *On*. If a module is enabled the UMC monitors the presence of the module and creates by default a fault in the event that the module is missing (-> parameter '*Missing Module Reaction*').

Before the voltage module can be used the parameters listed below must be adjusted. For the voltage based protection parameters see section "*Voltage and Power Protection Functions*".

##### Using the Relay Output

The relay output is connected to the fieldbus command telegram and can be controlled from the control system. See the fieldbus command telegram for the relevant bit position. By default it is not used by the UMC in any way. But it can be used in a customer specific function block application.



The relay output of the modules VI15x can be freely used in the Custom Application Editor. Consult the editor's manual if you plan to use the output directly in the UMC.

Relevant Module Parameters:

<ul style="list-style-type: none"> <li>• <i>VI15x Enabled</i></li> <li>• <i>Nominal Line Voltage</i></li> <li>• <i>Nominal power factor (cos phi)</i></li> <li>• <i>Number of phases</i></li> </ul>	<ul style="list-style-type: none"> <li>• <i>Missing Module Reaction</i></li> </ul>
-----------------------------------------------------------------------------------------------------------------------------------------------------------------------------------------------------	------------------------------------------------------------------------------------

# Universal Motor Controller

## UMC100-FBP

### Technical Description

## 8 The LCD Control Panel UMC100-PAN

### Overview

The UMC100-PAN provides a easy to use multi-language user interface for the UMC100. In this chapter you will find the following information:

- menu structure
- how to operate the UMC100 with the LCD panel
- how to acknowledge faults
- how to watch process data
- how to configure the UMC100 using the LCD panel
- how to use the LCD panel as parameter storage (e.g. for backup purposes)

See the "Installation" chapter if you are looking for information on how to connect and wire the LCD panel.

The UMC100-PAN can be either plugged directly on the UMC or mounted on the switchgear door using the door mounting kit. The following diagram shows the LCD panel with its buttons, LEDs and LCD area.



This chapter describes how the parameters can be accessed from the UMC100-PAN. Please look into section "Parameters and Data-Structures on a Fieldbus" for an explanation of the parameters and also for an alphabetical list.

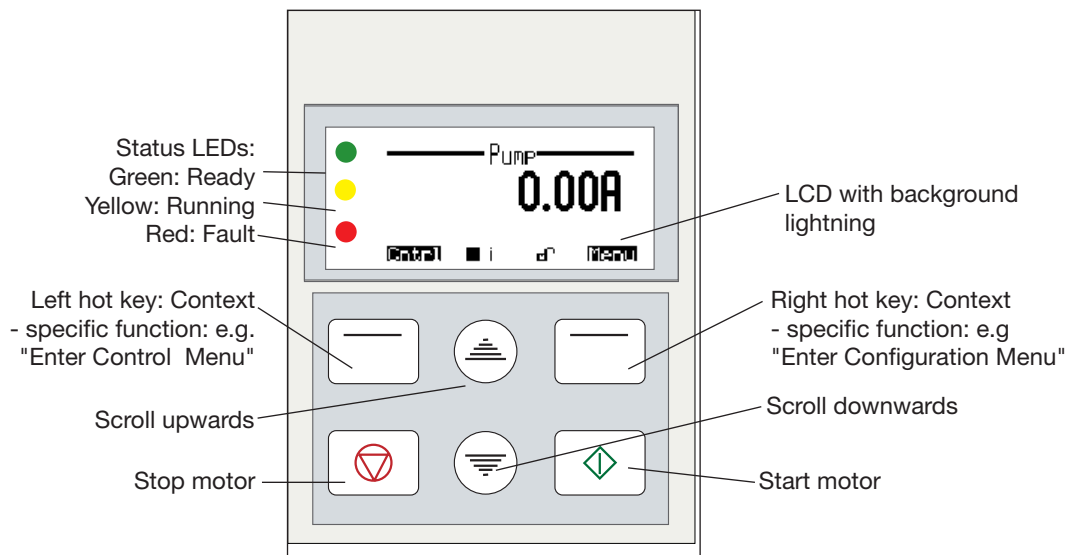



# Universal Motor Controller

## UMC100-FBP

### Technical Description

Masks on the top level and the main configuration menu masks.

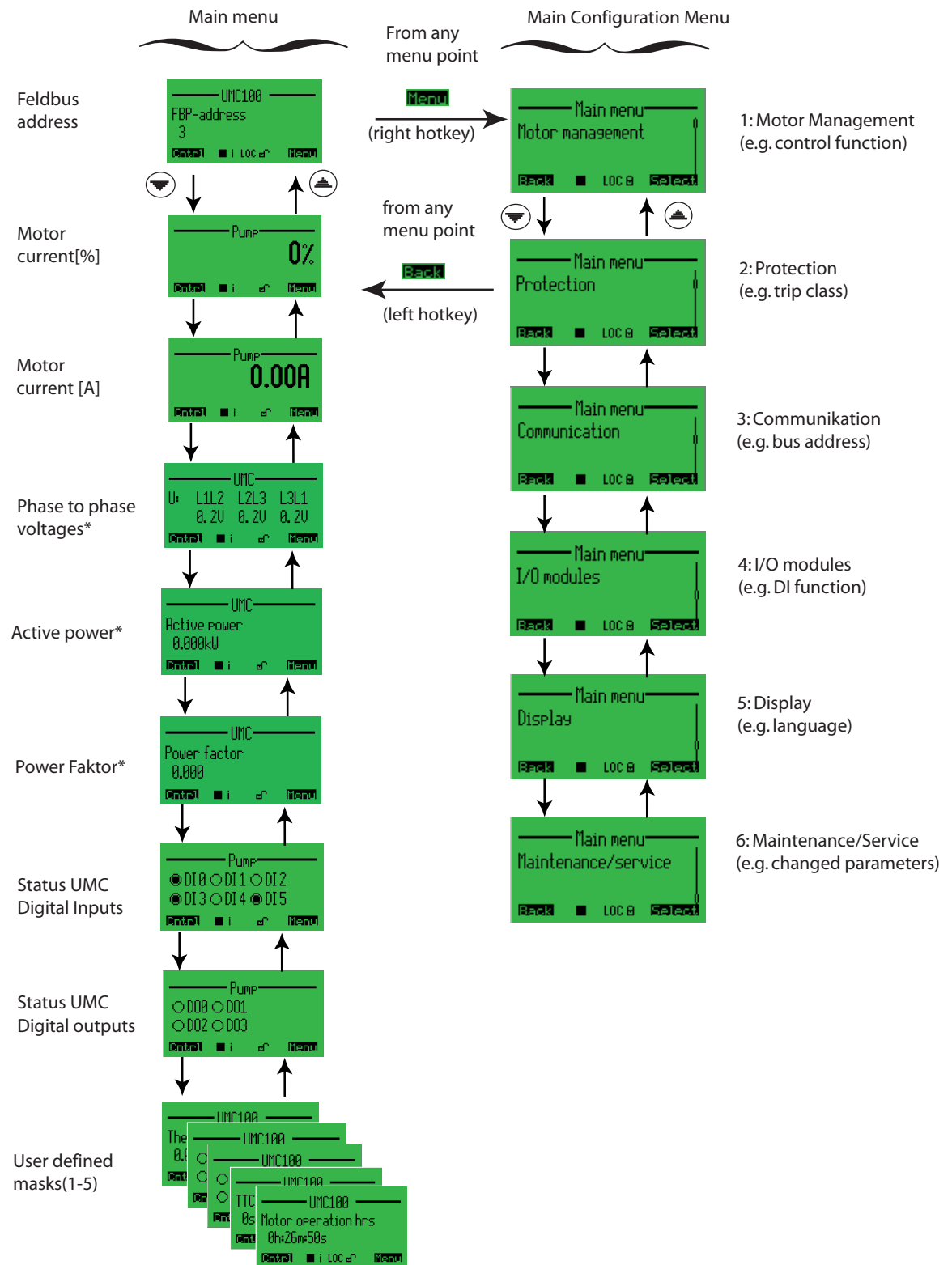

With the right soft key **Select** you can enter the selected submenus which are described in the following sections. The masks shown with a star \* are only displayed if the voltage module is present.

# Universal Motor Controller

## UMC100-FBP

### Technical Description

#### Motor Management Parameters

Within this submenu all motor management related parameters can be configured. The diagram below shows the organisation of the different parameter masks in the menu tree.



The parameters are described in details in the section "Parameters and Data Structures on a Fieldbus->Parameter Organisation-> Motor Management Parameters". A description of the parameters of the menu entry "Auxiliary inputs" can be found in the section "Parameters and Data-Structures on a Fieldbus->Parameter Organization-> Function Block Related Parameters".

#### 1 Motor Management

- 1.1 Control function
- 1.2 Reverse lockout time<sup>1</sup>
- 1.3 YD changeover mode<sup>2</sup>
- 1.4 YD starting time<sup>2</sup>
- 1.5 Time limit actuator<sup>3</sup>
- 1.6 Fault output
- 1.7 Checkback
- 1.8 Inching DI start input
- 1.9 **Local ctrl mode 1**
- 1.10 **Auto ctrl mode**
- 1.11 **Local ctrl mode 2**
- 1.12 **Invert ctrl inputs**
- 1.13 **Multifunction inputs**
- 1.14 Enable custom logic
- 1.15 Limit number of starts
- 1.16 **Extended**

- 1) Only for control function REV
- 2) Only for control function YD
- 3) Only for control function Actuator

#### 1.9 Local control mode 1

- 1.9.1 Loc1 start bus cyc.
- 1.9.2 Loc1 stop bus cyc.
- 1.9.3 Loc1 start LCD
- 1.9.4 Loc1 stop LCD
- 1.9.5 Loc1 start bus acyc.
- 1.9.6 Loc1 stop bus acyc.
- 1.9.7 Loc1 start DI
- 1.9.8 Loc1 stop DI

#### 1.10 Auto ctrl mode

- 1.10.1 Auto start bus cyc.
- 1.10.2 Auto stop bus cyc.
- 1.10.3 Auto start LCD
- 1.10.4 Auto stop LCD
- 1.10.5 Auto start bus acyc.
- 1.10.6 Auto stop bus acyc.
- 1.10.7 Auto start DI
- 1.10.8 Auto stop DI

#### 1.16 Extended

- 1.16.1 Checkback time
- 1.16.2 Emergency start
- 1.16.3 Fault auto reset
- 1.16.4 Custom app parameter
- 1.16.5 **Auxiliary inputs**

#### 1.16.5 Auxiliary inputs

- 1.16.5.1 Aux inp 1 ack mode
- 1.16.5.2 Aux inp 1 reaction
- 1.16.5.3 Aux inp 1 delay
- 1.16.5.4 Aux inp 1 message L1
- 1.16.5.5 Aux inp 1 message L2
- ... (Same repeats for Aux 2 ... 6)

#### 1.11 Local control mode 2

- 1.11.1 Loc2 start bus cyc.
- 1.11.2 Loc2 stop bus cyc.
- 1.11.3 Loc2 start LCD
- 1.11.4 Loc2 stop LCD
- 1.11.5 Loc2 start bus acyc.
- 1.11.6 Loc2 stop bus acyc.
- 1.11.7 Loc2 start DI
- 1.11.8 Loc2 stop DI

#### 1.13 Multifunction inputs

- 1.13.1 Multifunction 0
- 1.13.2 Multifunction 1
- 1.13.3 Multifunction 2
- 1.13.4 Multif. 0 delay
- 1.13.5 Multif. 1 delay
- 1.13.6 Multif. 2 delay
- 1.13.7 Multif. 0 autoreset
- 1.13.8 Multif. 1 autoreset
- 1.13.9 Multif. 2 autoreset
- 1.13.10 Multif. 0 fault text L1/2
- 1.13.12 Multif. 1 fault text L1/2
- 1.13.14 Multif. 2 fault text L1/2

#### 1.12 Invert ctrl inputs

- 1.12.1 Invert DI start inp.
- 1.12.2 Invert DI stop inp.

#### 1.15 Limit num of starts

- 1.15.1 Num starts allowed
- 1.15.2 Num starts window
- 1.15.3 Num starts pause
- 1.15.4 Num starts overrun
- 1.15.5 Num starts prewarn

# Universal Motor Controller

## UMC100-FBP

### Technical Description

#### Motor Protection Parameters

Within this submenu all motor protection related parameters can be configured. The diagram below shows the organisation of the different parameter masks in the menu tree.



The parameters are described in detail in the section "Parameters and Data Structures on a Fieldbus->Parameter Organisation-> Motor Protection Parameters".

#### 2 Protection

- 2.1 Setting Ie 1
- 2.2 Setting Ie 2\*
- 2.3 Trip class
- 2.4 Current factor
- 2.5 PTC
- 2.6 Cooling mode
- 2.7 Cooling time
- 2.8 Restart level %
- 2.9 **Locked rotor (LR)**
- 2.10 Thermal load warnlev
- 2.11 **Phases**
- 2.12 **Over/under current**
- 2.13 **Int. earthfault**
- 2.14 **Voltage DIP\*\***
- 2.15 **Over/under voltage\*\***
- 2.16 **Voltage imbalance\*\***
- 2.17 Load startup delay\*\*
- 2.18 **Over/under power\*\***
- 2.19 **Power factor\*\***
- 2.20 **Power quality\*\***

\*) Polechanging starter only  
 \*\*) With voltage module only

#### 2.9 Locked Rotor

- 2.9.1 LR trip level
- 2.9.2 LR trip delay

#### 2.11 Phases

- 2.11.1 Phase loss protect.
- 2.11.2 Phase imb. trip lev.
- 2.11.3 Phase imb. warn lev.
- 2.11.4 Phase reversal
- 2.11.5 Check phase sequence

#### 2.12 Over / under current

- 2.12.1 Low curr trip level
- 2.12.2 Low curr trip delay
- 2.12.3 Low curr warn level
- 2.12.4 Low curr warn delay
- 2.12.5 High curr trip level
- 2.12.6 High curr trip delay
- 2.12.7 High curr warn level
- 2.12.8 High curr warn delay

#### 2.13 Int. earthfault

- 2.13.1 Earthflt. trip lev.
- 2.13.2 Earthflt. trip delay
- 2.13.3 Earthflt. warn lev.
- 2.13.4 Earthflt. warn delay
- 2.13.5 Earth fault detection

#### 2.14 Voltage DIP

- 2.14.1 Enable voltage DIP
- 2.14.2 Voltage DIP duration
- 2.14.3 Autorestart enable
- 2.14.4 Autorestart window
- 2.14.5 Autorestart delay
- 2.14.6 DIP restart level
- 2.14.7 DIP level

#### 2.15 Over / under voltage

- 2.15.1 U low trip level
- 2.15.2 U low trip delay
- 2.15.3 U low warn level
- 2.15.4 U low warn delay
- 2.15.5 U high trip level
- 2.15.6 U high trip delay
- 2.15.7 U high warn level
- 2.15.8 U high warn delay

#### 2.16 Voltage imbalance

- 2.16.1 U imb trip level
- 2.16.2 U imb trip delay
- 2.16.3 U imb warn level
- 2.16.4 U imb warn delay

#### 2.18 Over / under power

- 2.18.1 P low trip level
- 2.18.2 P low trip delay
- 2.18.3 P low warn level
- 2.18.4 P low warn delay
- 2.18.5 P high trip level
- 2.18.6 P high trip delay
- 2.18.7 P high warn level
- 2.18.8 P high warn delay

#### 2.19 Power factor

- 2.19.1 PwrFactor trip level
- 2.19.2 PwrFactor trip delay
- 2.19.3 PwrFactor warn level
- 2.19.4 PwrFactor warn delay

#### 2.20 Power quality

- 2.20.1 THD warn level
- 2.20.2 THD warn delay

# Universal Motor Controller

## UMC100-FBP

### Technical Description

#### Communication Parameters

Within this submenu all communication related parameters can be configured. The diagram below shows the organisation of the different parameter masks in the menu tree. The parameters are described in details in the section "Parameters and Data Structures on a Fieldbus->Parameter Organisation->Communication Parameters".

#### 3 Communication

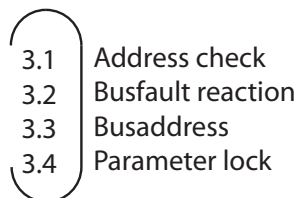

#### IO Module Parameters

Within this submenu all IO module related parameters can be configured. The diagram below shows the organisation of the different parameter masks in the menu tree. The parameters are described in details in the section "Parameters and Data Structures on a Fieldbus->Parameter Organisation->IO Module Parameters".

#### 4 IO Modules

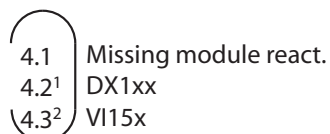

1) Only shown if DX1xx is enabled  
2) Only shown if VI15x is enabled

#### 4.2 DX1xx

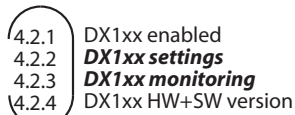

#### 4.2.2 DX1xx settings

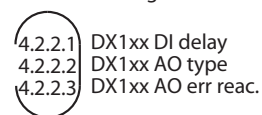

#### 4.3 VI15x

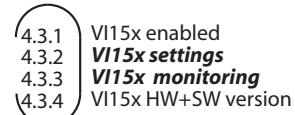

#### 4.3.2 VI15x settings

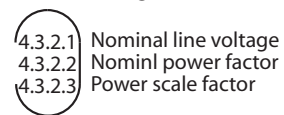

#### Display Parameters

Within this submenu all LCD display related parameters can be configured. The figure below shows the organization of the different parameter masks in the menu tree. The parameters are described in details in the section "Parameters and Data Structures on a Fieldbus->Parameter Organization->Display Parameters".

#### 5 Display

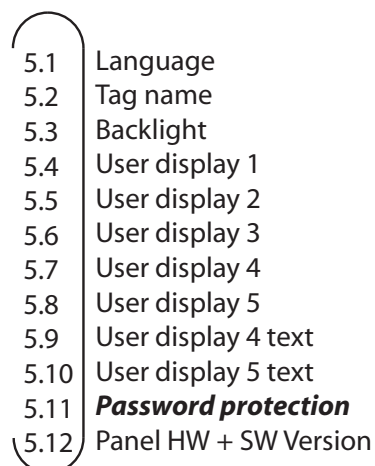

#### 5.11 Password protection

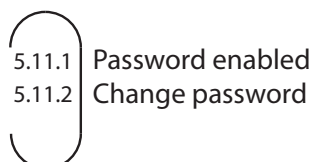

# Universal Motor Controller

## UMC100-FBP

### Technical Description

#### Maintenance and Service Parameters/Actions

Within this submenu all maintenance and service related parameters / actions can be configured. The figure below shows the organisation of the different parameter masks in the menu tree.

Menu point 6.3.1 shows the list of errors and their occurrence in seconds since the start-up of the UMC. After a power cycle the history buffer is cleared. Use the up/down keys to scroll within the list.

Menu point 6.3.2 shows present warnings. The "i" in the icon bar on the top level masks indicates the presence of warnings. Use the up/down keys to scroll within the list.

Menu point 6.5 lists all changed parameters. This is useful if you want to verify the parameterization was carried out correctly or when calling a technical specialist who wants to know what has been configured.

Menu point 6.4 allows to transfer the parameters and/or the application to the LCD panel and back.

#### 5 Maintenance / service

- 6.1 **Maintenance counters**
- 6.2 **Service tasks**
- 6.3 **Diagnosis**
- 6.4 **Parameter transfer**
- 6.5 Changed parameters
- 6.6 UMC100 SW version

#### 6.1 Maintenance counters

- 6.1.1 Motor operation hours
- 6.1.2 Number of starts
- 6.1.3 Number of trips
- 6.1.4 Remaining starts

#### 6.2 Service Tasks

- 6.2.1 Set operation hours
- 6.2.2 Reset oper. hours
- 6.2.3 Reset num. of starts
- 6.2.4 Reset num. of trips
- 6.2.5 Reset parameters
- 6.2.6 Reset energy

#### 6.3 Diagnosis

- 6.3.1 Error history
- 6.3.2 Present warnings

#### 6.4 Parameter transfer

- 6.4.1 **Upload to LCD panel**
- 6.4.2 **Download to UMC**

#### 6.4.1 Upload to LCD panel

- 6.4.1.1 Only parameter
- 6.4.1.2 Only application
- 6.4.1.3 Par and application

#### 6.4.2 Download to UMC

- 6.4.2.1 Only parameter
- 6.4.2.2 Only application
- 6.4.2.3 Par and application

# Universal Motor Controller

## UMC100-FBP

### Technical Description

#### Adjusting Parameters

##### Adjusting a Numerical Value

This type of dialog allows a numerical value to be specified within the given limits. The single digits must be defined from right to left. If the last digit was reached the right hot key changes from 'Next' to 'Save'. When pressing 'Save' the specified value is stored in the UMC. The mask can be exited at any time with the Cancel button (left hot key). In this case the changes are discarded.

The following example shows how to set the nominal motor current  $I_{e1}$ .

To change the digit use the up/down keys. As it is not possible to enter a value outside the given limits start editing the first digit by pressing the up button. If you reach 10, a 0 is displayed in the first digit and a 1 in the second digit. Press the left hot key now to go to the next digit.

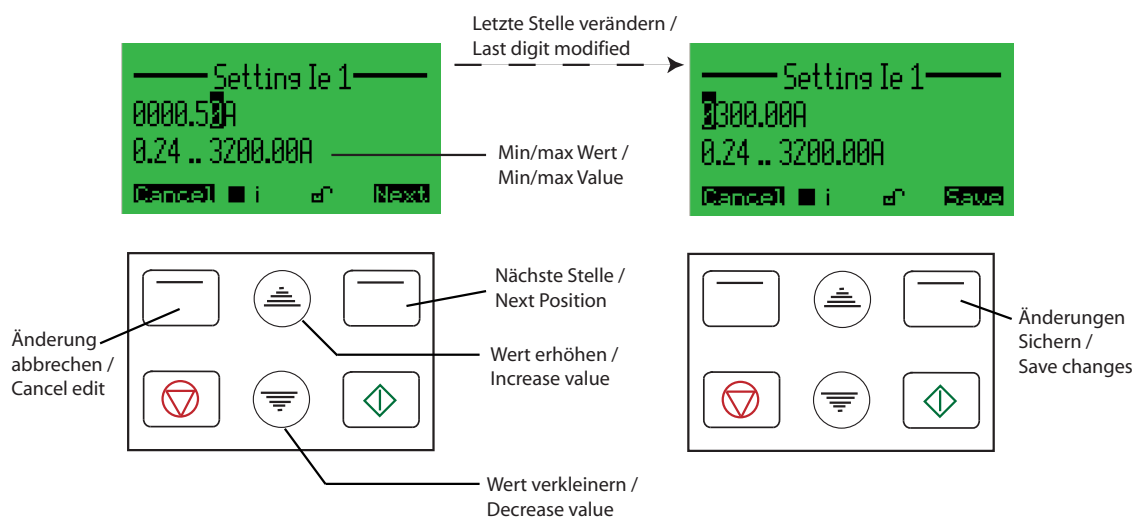

##### Selecting an Option from a List

This type of dialog allows an item to be selected from a given list of options. With the up/down keys you can scroll through the list. The slider on the right shows the current position within the list. Pressing 'Select' chooses the currently marked item (inverted). Pressing 'Cancel' exits the dialog and discards the selection.

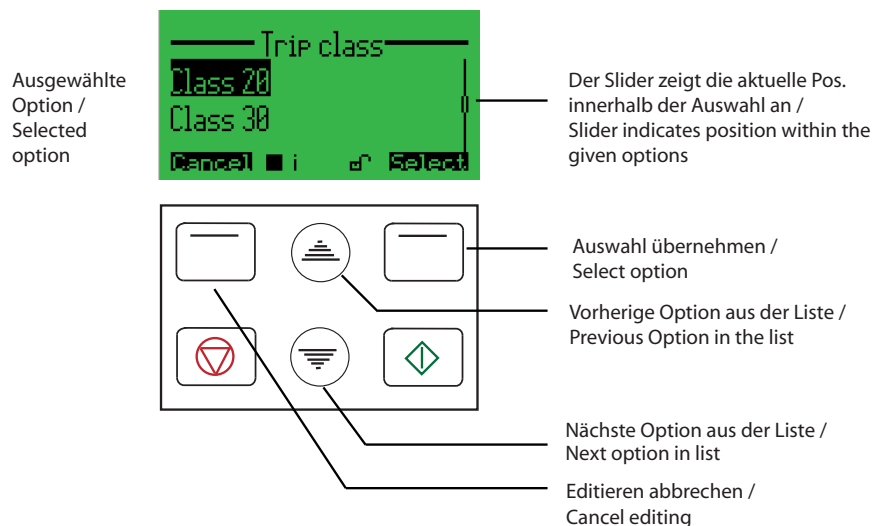

# Universal Motor Controller

## UMC100-FBP

### Technical Description

#### Specifying a Text String

This type of dialog allows a character string to be specified e.g. an error message. With the up/down keys you can scroll through the alphabet and several special characters. Pressing 'Next' selects the next character to edit. When the last character is reached you can save the text string by pressing 'Save' or discard the changes pressing 'Cancel'.

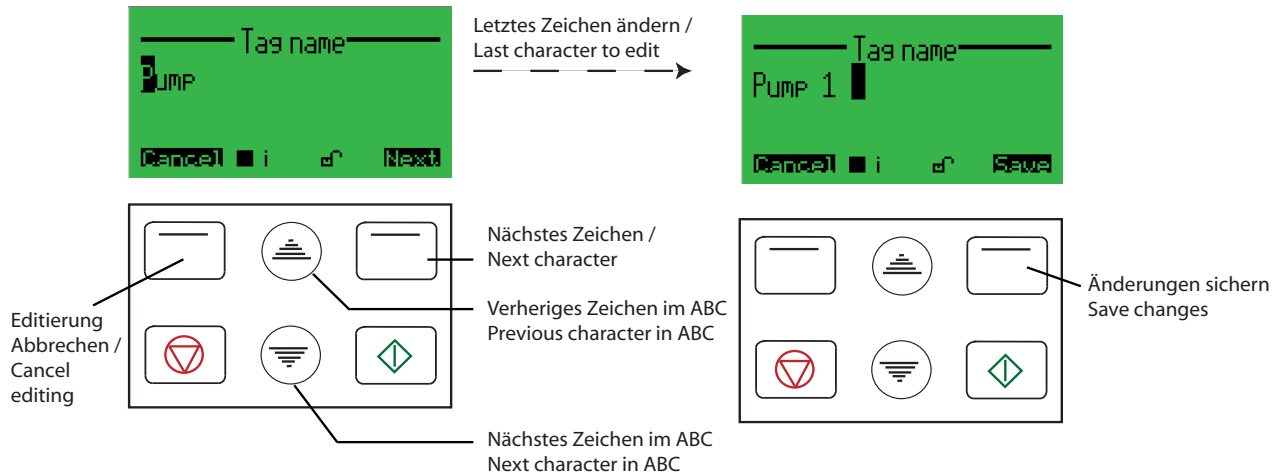

#### Use the LCD panel as parameter storage

For backup purposes or if several UMCs should be configured with a similar or same set of parameters the LCD panel can be used as storage.

You can choose if you uploaded or download only the application or only the parameters or both.



Please note that the bus address will not be overwritten during download. This prevents communication problems due to the usage of the same bus addresses multiple times.

In case of a device replacement this means that the bus address must be set separately!

# Universal Motor Controller

## UMC100-FBP

### Technical Description

#### Starting and Stopping the Motor

If control via LCD panel was enabled, it is possible to start/stop the motor from the 'Control' menu which can be accessed from the top level menu when pressing the left hot key (Cntrl). Depending on the selected control function a list of possible start directions is displayed. Pressing the green start button starts the motor in the selected direction. Pressing the red stop button stops the motor. The motor status icons show you the present status of the motor.

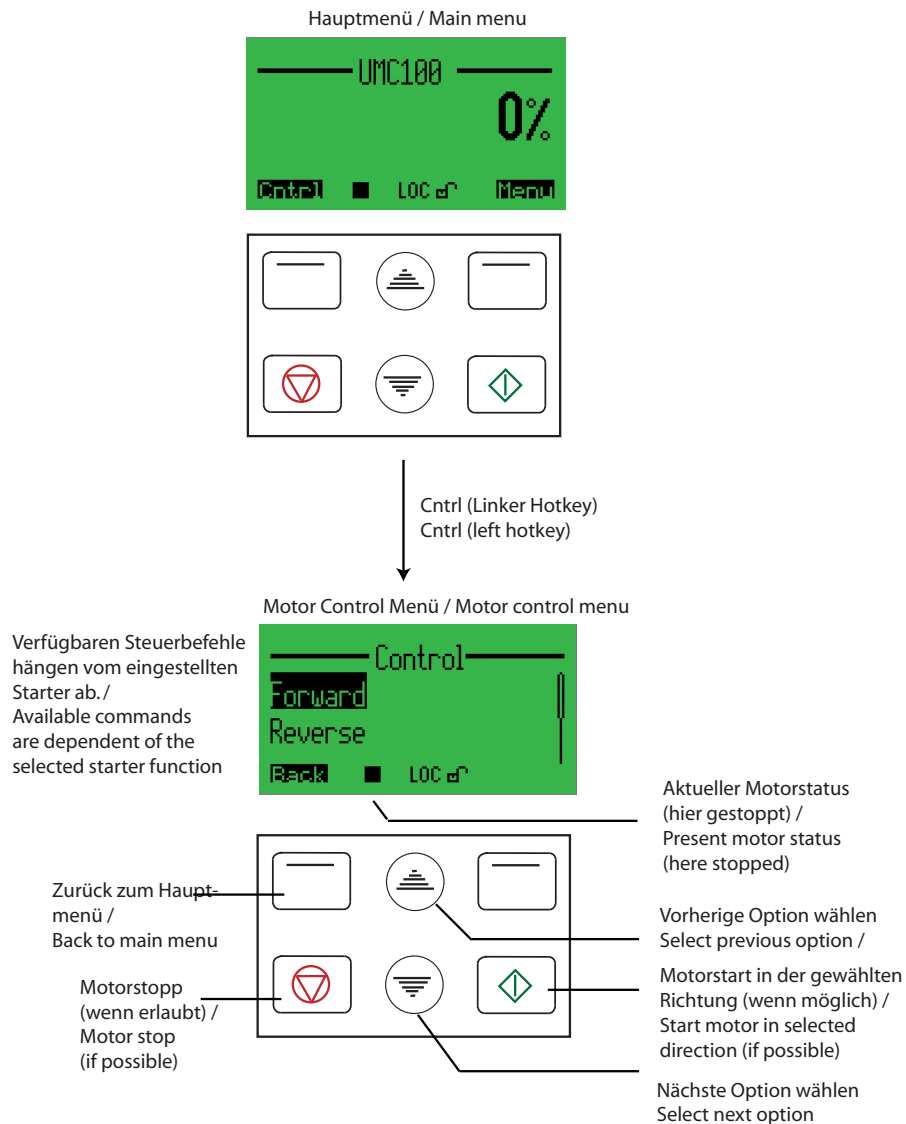

# Universal Motor Controller

## UMC100-FBP

### Technical Description

#### Acknowledge a Fault

If a fault is present the 'Cntrl' menu is replaced with the menu to acknowledge faults (top level menu, left hot key). While a fault is present it is not possible to enter the Motor Control menu until the fault has been acknowledged. When entering the error menu the latest fault message is displayed. By pressing the right hot key 'Reset' you acknowledge the fault.

If there is another fault pending it is displayed and can also be acknowledged until there is no further fault pending. Using the up/down keys it is possible to scroll through the list of present faults before acknowledging them. If the last fault was acknowledged the main menu is automatically entered.

The menu can be exited at any time pressing the left hot key 'Back' without resetting any faults.

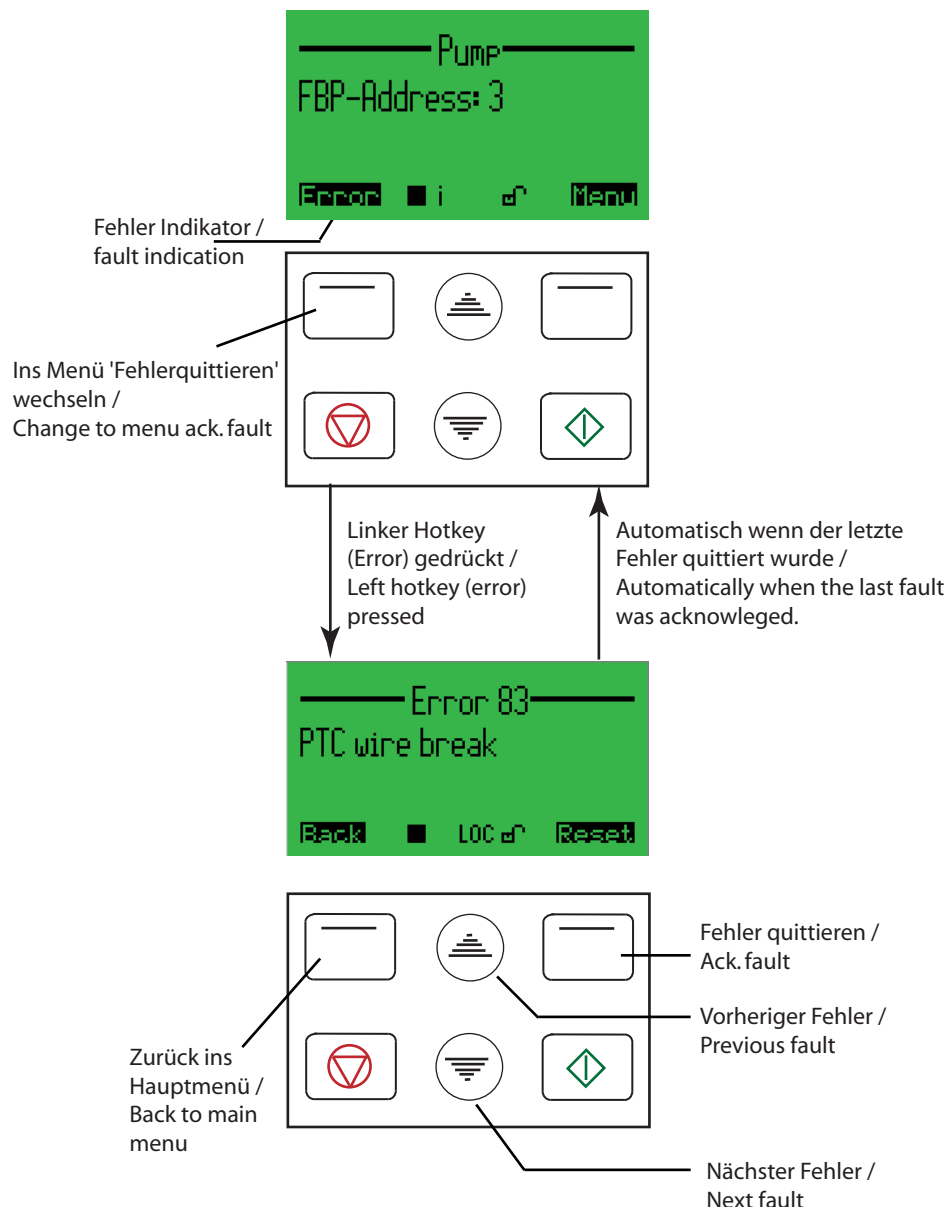

The table in the section "Error Handling, Maintenance and Service->Error Handling of the UMC" lists all diagnosis and fault messages and potential root causes for the fault. It gives you a first indication of where to look for a fault and how to fix it. Use the error number shown in the heading (Error 83 in the example) for the look-up table.

---

**Universal Motor Controller  
UMC100-FBP  
Technical Description**

---

---

# Universal Motor Controller

## UMC100-FBP

### Technical Description

---

## 9 Error Handling, Maintenance and Service

Within this chapter you will find the following information

- Error handling of the UMC
- Detailed explanation of all error and diagnosis messages
- Functions related to maintenance and service

### Error Handling of the UMC

When the UMC detects a fault condition the fault becomes latched. Once a fault becomes latched, it remains latched - even if the underlying fault condition is eliminated - until acknowledged by a fault reset command.

### Automatic Reset of Protection Faults

The setting of the "*Fault autoreset*" parameter determines how the UMC manages protection trips.

- *Off* (the default setting): A protection trip must be acknowledged by the user. This can be done via LCD panel, fieldbus or the multifunction inputs DI0-DI2 if configured.
- *On*: A protection trip is automatically acknowledged without intervention of either a human operator or the remote PLC if the trip condition has gone (e.g. cooling time over).

### Fault History

The PBDTM/UMC100 operator panel provides access to the fault history. The last 16 faults and their arrival time in seconds since power on are displayed. If the UMC is switched off the fault history is cleared.

### UMC100 Fault Indication

The UMC offers the following possibilities for indicating a fault.

- Fault indication via digital outputs: The outputs DO2 and DO3 can be used to signal a summary fault. DO2 is a relay output that uses the same supply as DO0 and DO1. DO3 is a 24VDC output and can be used to drive a signal lamp as an example. The fault outputs can be configured with the parameter *Fault Outputs*.
- Fault indication via LEDs on the UMC: The red fault LED is switched on in the event of a fault and remains on until the fault is acknowledged.
- Fault messages on the LCD panel: See the table below.
- Signalling via fieldbus: In the event of a fault the "Fault Bit" in the cyclic communication telegram is set to logical-1. Furthermore a diagnosis telegram (if supported by the used fieldbus) is generated that describes the fault details.

### Fault Messages

The following table lists all diagnosis and fault messages and potential root causes for the fault. It gives you a first indication of where to look for a fault and how to fix it.

Indicator	Code	Source / Root Cause	Possible Cause / Suggested Action
Thermal overload trip	0	Load side	Trip because of thermal overload of the motor.  Check process conditions Check if the cooling time is too short Check $I_e$ and trip class settings Check current factor if configured

# Universal Motor Controller

## UMC100-FBP

### Technical Description

Indicator	Code	Source / Root Cause	Possible Cause / Suggested Action
Phase loss	1	Supply side Load side Contactors	At least one phase current is below the phase loss threshold  Check for blown fuse Check for loose contacts Check contact wear
Phase imbalance	2	Supply side Load side Contactors	The current in one phase is below the adjusted threshold.  Check supply side Check for loose contacts Check contact wear
Locked Rotor	3	Load Side	The rotor is locked. Load too heavy for motor.
Thermal model reached warning level	4	Load Side	Thermal model reached warning level. If overload condition remains a trip soon follows.  Check motor load condition Check for mechanical problems
PTC overtemperature	5	Load side Environment	PTC element indicated that motor temperature is too high  Check motor environment and load conditions
PTC wiring problem	6	Summary message. See detailed messages for more information.	See codes 83/84
Check-back error	7	Summary message. See detailed messages for more information.	See codes 80...82
Motor current below low current trip threshold	8	Process Load side Load side mechanics	Motor current is below user-defined threshold e.g. motor running idle, dry running pump, conveyer belt broken ...  Check motor load and motor / process conditions. Wait until cooling time is over.
Motor current below low current warning threshold	9	Process Load side Load side mechanics	Motor current is below user-defined threshold e.g. motor running idle, dry running pump, conveyer belt broken ...  Check motor load and motor / process conditions
Motor current above high current trip threshold	10	Load side	Motor current above threshold caused e.g. by jammed equipment  Check process conditions (remove blocking cause). Wait until cooling time is over.
Motor current above high current warning threshold	11	Load side	Motor current above user-defined threshold.  Check motor load and motor / process conditions.

# Universal Motor Controller

## UMC100-FBP

### Technical Description

Indicator	Code	Source / Root Cause	Possible Cause / Suggested Action
Earth fault (external or internal sensor) above trip threshold	12	Load side electrical	Connection between one or more phases and ground Check wiring / motor (isolation problem)
Earthfault current above warning threshold	13	Load side electrical	See above
UMC self-test error	14	Electronics	Hardware fault detected Replace UMC
Actuator problem	15	Load side mechanics	Open/close time of actuator exceeded because of tight valve or other mechanical reasons. Check runtime parameter and limit and torque switch wiring
IO module missing	16	Electronics, Wiring	Communication cable not connected. Cable break or IO module hardware error.
Custom application error (e.g. download incomplete)	17	Configuration	An unrecoverable error was detected while processing the custom application (e.g. checksum error) The version of application editor and UMC are not compatible
IO module error	18	Electronics	A self-test error was detected in an IO module. Check the LEDs on the module Replace the module
Aux1: Error or warning triggered from auxiliary function block input 0	19	User-defined	The digital input of an IO module has created a trip/warning. Reason depends on what you have connected to the input.  Note: If the "AuxWarnFault" function block is used in a different way than in the predefined applications also other inputs than the DX1xx can be the fault source.
Aux2: Error or warning triggered from auxiliary function block input 1	20	User-defined	
Aux3: Error or warning triggered from auxiliary function block input 2	21	User-defined	
Aux4: Error or warning triggered from auxiliary function block input 3	22	User-defined	
Aux5: Error or warning triggered from auxiliary function block input 4	23	User-defined	
Aux6: Error or warning triggered from auxiliary function block input 5	24	User-defined	
Multifunction input 0	25	User-defined	A multifunction input of the UMC has triggered a trip. The reason depends on what you have connected to the input.
Multifunction input 1	26	User-defined	
Multifunction input 2	27	User-defined	
Underload Power	34	Load side mechanics	The motor load is too low. Check the load e.g. if a pump is running dry or a conveyer load is broken.

# Universal Motor Controller

## UMC100-FBP

### Technical Description

Indicator	Code	Source / Root Cause	Possible Cause / Suggested Action
Overload Power	35	Load side mechanics	The motor load is too high. Check if the load is blocked or tight.
Voltage Out of Spec	36	Load side	The supply voltage is too low or too high. Check the motor supply.
THD Warning	37	Supply side	The harmonics on the supply side are too high. Check your network.
Num Starts Overrun	43	Application	The motor was started too frequent.
Just One Start Left	44	Application	The motor was started too frequent.
Cooling time running	45	Process, Load side	Motor was tripped due to thermal overload. Restart is possible after cooling time is over
Parameter out of range	54	Electronics, Configuration	Someone tried to write a parameter which is outside the specifications  Check the parameter number that is causing the problem and change the value. When writing parameters from within a PLC check your program.
Torque open in intermediate position	64	Actuator mechanics	Tight operation or wiring problem.
Torque close in intermediate position	65	Actuator mechanics	Tight operation or wiring problem.
Pos. open and closed at same time	66	Actuator mechanics	Wiring / position switch problem
End pos. open not left within specified time	67	Actuator mechanics	Wiring / position switch problem or wrong adjustment of position switch.
End pos. closed not left within specified time	68	Actuator mechanics	Wiring / position switch problem or wrong adjustment of position switch.
End position open without command	69	Actuator mechanics	Wiring / position switch problem.
End position closed without command	70	Actuator mechanics	Wiring / position switch problem.
Left pos. open without command	71	Actuator mechanics	Wiring / position switch problem.
Left pos. close without command	72	Actuator mechanics	Wiring / position switch problem.
Motor operation hour exceeded	74	Load side mechanical	Max. motor operation hours reached.  Perform motor maintenance Reset counter
Wrong password	76	Electronics	
Line frequency out of range	77	Supply side	Check supply
Wrong phase sequence (reversal)	78	Supply side, Load side	Phase order is not L1/L2/L3.

# Universal Motor Controller

## UMC100-FBP

### Technical Description

Indicator	Code	Source / Root Cause	Possible Cause / Suggested Action
CB relay 0	80	Wiring, Contactors	Expected feedback from a contactor is missing after checkback time was over.  Check wiring of auxiliary contact to the correct UMC input. Check contactor Increase checkback time
CB current	82	Contactors, Supply side, Load side	No motor current after motor was switched on and checkback time was over. Or motor current falls below 20% while motor is running.  Check supply side Check that $I_e$ was set correctly Check current factor if set Increase checkback time
PTC wire break	83	Wiring	Check between UMC and motor
PTC short-circuit	84	Wiring	Check wiring between UMC and motor
DX111/DX122 module missing	85	Wiring, Electronics	The IO module does not respond during start-up of UMC.  Check wiring between UMC and module Check supply of module Check status LEDs of the module
VX1xx module missing	88	Wiring, Electronics	The VI15x module does not respond during start-up of the UMC.  Check wiring between UMC and module Check supply of module Check status LEDs of the module
Overload analog output DX111/DX122	92	Wiring, connected meter has a defect	Check wiring, short circuit at analogue output
Wire break analogue output DX111/DX122	93	Wiring	Check Wiring
Self-test failure DX111/DX122	94	Wiring	Check Wiring
U below trip/warn level	95, 96	Motor supply voltage is too low.	Check supply side: E.g. circuit breaker, fuses, wiring and the feeding.
U above trip/warn level	97, 98	Motor supply voltage is too high.	Check supply side: E.g. circuit breaker, fuses, wiring and the feeding.
P below trip/warn level	116, 117	Active power consumption of the motor is too low.	Either the motor is idle (not loaded) or the motor load is not connected because of a broken belt or a dry running pump etc.  Check load side

# Universal Motor Controller

## UMC100-FBP

### Technical Description

Indicator	Code	Source / Root Cause	Possible Cause / Suggested Action
PF below trip/warn level	120, 121	Active power consumption of the motor is too low	Either the motor is idle (not loaded) or the motor load is not connected because of a broken belt or a dry running pump etc. Check load side
Phase loss (voltage)	122	No voltage on one or more phases. Possible causes are a blown fuse or a wire break.	Check fuses Check wiring on supply side.
Phase imbalance (voltage)	123	There is a high imbalance on supply side e.g. because of unsymmetrical load of the three phases.	Check supply side especially the fuses and supply line.
Voltage out of range	124	The voltage is out of the specified voltage range	Check supply side. See 95 – 98.
Wrong Phase Sequence (voltage)	125	The phases were wired in incorrect order.	Check wiring
Voltage DIP	144	Undervoltage / no voltage situation is too long	The DIP took longer than configured in parameter <i>Voltage Dip Duration</i>
Parameter up/download	145	A problem occurred during parameter exchange between the UMC and the LCD panel.	Check that the parameters / application stored in the LCD panel can be handled from the used UMC. Do not remove the panel while parameter exchange Do not remove power while parameter exchange.

#### Resetting Parameters to Factory Defaults

It is possible to reset all parameters to the factory default settings. The fieldbus address is not affected from the reset command. Also the different maintenance counters are not affected but must be resetted manually at the UMC100-PAN.

The reset command can be activated via:

- UMC100-PAN

#### Resetting the Password

The password can always be set or disabled using the UMC100 DTM (PBDTM) or using the UMC100-PAN.

---

# Universal Motor Controller

## UMC100-FBP

### Technical Description

---

#### **Reading, Setting and Resetting Maintenance Counters**

Preventive maintenance is the best way to ensure the long service life of any equipment.

The UMC provides several counters which help to better plan maintenance activities or to track down an existing problem.

- Number of motor starts can help to identify worn-out power contacts or to determine on contactor wear
- Number of protection trips
- Motor operation hours can help to assess the bearing status and its lubrication

The maintenance counters are available at the UMC100-PAN and in the PBDTM.

# Universal Motor Controller

## UMC100-FBP

### Technical Description

#### DX1xx / VI15x Status Codes

Three LEDs show the module status. The following table explains the status messages.

Status			Explanation
Green LED	Yellow LED	Red LED	
On	On	On	Self-test during start-up
Flashing	Off	On	Communication with UMC was interrupted. Relay outputs switched off. Possible cause: Wiring between UMC and IO module broken. Possible corrective measure: Check wiring and check that the module was activated in the UMC configuration.
Flashing	Off	Off	Waiting for communication with UMC. Module is ready. Possible cause: Wiring between UMC and IO module broken. Possible corrective measure: Check wiring and check that the module was activated in the UMC configuration.
On	Off	Off	Cyclic data exchange with UMC. No diagnosis.
On	Flashing	Off	Cyclic data exchange with UMC. Diagnosis exists.
Irrelevant		Flashing	Hardware defect.
		Flashing	Possible corrective measure: Replace module.

#### Replacing a UMC100

The UMC and the current transformer are calibrated together in the ABB factory. Therefore the UMC must be completely replaced.

The UMC can be disconnected from the FieldbusPlug without disturbing the fieldbus communication and the other slaves. The FieldbusPlug is supplied via the voltage conducted together with the bus lines. The FieldbusPlug keeps the actual slave address and informs the control system that the connected device is disconnected.

Set the parameters in the new UMC depending on your parameterisation concepts.



If you stored the parameters and/or your user defined application in the UMC100-PAN you can just download them from the panel back to the UMC100.

After mounting and connecting a new UMC, the communication starts up again.

#### Replacing a DX1xx IO Module

DX1xx modules are automatically parameterized by the UMC if the communication between UMC and IO module has been established. No further user actions are required.

#### Replacing a VI15x Module

VI15x modules are automatically parameterized by the UMC if the communication between UMC and module has been established. No further user actions are required.

#### Requesting Support

If you need support we kindly ask you to contact your local ABB representative using the template provided at the end of this manual.

#### Check the Configuration

The menu option "Changed parameters" in the Service menu displays all parameters with changed settings (i.e., parameters with settings different from the default settings). Using this function you can quickly check whether all parameters are set correctly

# Universal Motor Controller

## UMC100-FBP

### Technical Description

#### A1 Parameters and Data Structures on a Fieldbus

In the following chapter you find a detailed description of all UMC parameters, the format of the command monitoring and diagnosis telegrams. Furthermore the information is provided of how the UMC data is mapped to the different FieldbusPlugs



The UMC100 version R0101 offers additional monitoring and command data compared to the version R0100/R0200. The data was added to previously unused positions in the telegrams to keep backwards compatibility.



The tables below represents the data allocation as realised with the built-in standard applications. It may differ for customer-specific applications!

#### Monitoring Data

Word	Byte	Bit 7	Bit 6	Bit 5	Bit 4	Bit 3	Bit 2	Bit1	Bit 0
0	0	Summary Warning	Summary Fault	Local Control <sup>3</sup>	Reverse Lockout Time <sup>3</sup>	Overload warning	Run Forward <sup>1,3</sup> / Opening <sup>2,3</sup>	Off <sup>3</sup>	Run Reverse <sup>1,3</sup> / Closing <sup>2,3</sup>
	1	UMC100 DI5	UMC100 DI4	UMC100 DI3	UMC100 DI2	UMC100 DI1	UMC100 DI0	Run Fast Forward <sup>4)</sup>	-
1	2, 3	Motor Current in % of I <sub>s</sub> (0% - 800%)							
2	4, 5	Analogue Word (Thermal Load: 0% - 100%)							
3	6, 7	Analogue Word (Time to trip in seconds)							
4	8, 9	Analogue Word (Time to restart in seconds)							
5	10,11	Analogue Word (Active power in selected scale)							
6	12	DX1xx DI7	DX1xx DI6	DX1xx DI5	DX1xx DI4	DX1xx DI3	DX1xx DI2	DX1xx DI1	DX1xx DI0
	13	-	-	Run Time Exceeded <sup>1</sup>	Out of Position <sup>1</sup>	Torque Open <sup>1</sup>	Torque Closed <sup>1</sup>	End Pos Open <sup>1</sup>	End Pos Closed <sup>1</sup>
7	14	U Imbal. warn	U Imbal. trip	Undervoltage warn	Undervoltage trip	Underpower warn	Underpower trip	Overpower warn	Overpower trip
	15	Earth fault warning	Earth fault trip	Cooling time running	-	THD warning	No start possible <sup>5)</sup>	1 start left <sup>5)</sup>	More than 1 start left <sup>5)</sup>

#### Command Data

Word	Byte	Bit 7	Bit 6	Bit 5	Bit 4	Bit 3	Bit 2	Bit1	Bit 0
0	0	-	Fault Reset	Auto Mode <sup>3</sup>	Prepare Emergency Start	-	Run Forward <sup>1,3</sup> / Opening <sup>2,3</sup>	Off <sup>3</sup>	Run Reverse <sup>1,3</sup> / Closing <sup>2,3</sup>
	1	UMC100 DO2	UMC100 DO1	UMC100 DO0	UMC100 24VDC Out	-	-	Run Fast Forward <sup>4)</sup>	-
1	2	V15x DO0	-	-	-	DX1xx DO3	DX1xx DO2	DX1xx DO1	DX1xx DO0
	3	-	-	-	-	-	-	-	-
2	4, 5	Analogue Word							
3	6, 7	Analogue Word							
4	8,9	Analogue Word							
5	10,11	Analogue Word							

<sup>1)</sup> Not for Actuator 1 ... 4

<sup>2)</sup> Only for Actuator 1 ... 4

<sup>3)</sup> Not for Overload Relay and Transparent

<sup>4)</sup> Only for Pole-Changing Starter

<sup>5)</sup> If *start limit function* is used

# Universal Motor Controller

## UMC100-FBP

### Technical Description

#### Diagnosis Data

Word	Byte	Bit 7	Bit 6	Bit 5	Bit 4	Bit 3	Bit 2	Bit 1	Bit 0
0	0	Checkback missing	PTC wiring failure	PTC hot	Pre-warming thermal model	Locked rotor during start-up (stall)	Phase imbalance <sup>1</sup>	Phase loss <sup>1</sup>	Thermal overload trip
	1	Actuator problem <sup>1</sup>	UMC self-test error	Earth fault pre-warming	Eart fault trip (internal or externally triggered)	I above high current warning threshold	I above high current trip threshold	I below low current warning threshold	I below low current trip threshold
1	2	Trip/Warning from AuxFault function block input 5 <sup>2)</sup>	Trip/Warning from AuxFault function block input 4 <sup>2)</sup>	Trip/Warning from AuxFault function block input 3 <sup>2)</sup>	Trip/Warning from AuxFault function block input 2 <sup>2)</sup>	Trip/Warning from AuxFault function block input 1 <sup>2)</sup>	HW fault on IO module	Custom application error	IO module missing
	3	-	-	-	-	Trip triggered from Multifunction input DI2	Trip triggered from Multifunction input DI1	Trip triggered from Multifunction input DI0	Trip / Warning from AuxFault function block input 6 <sup>2)</sup>
2	4	-	-	THD Warning	Voltage out of spec <sup>1</sup>	Overload power	Underload power <sup>1</sup>	-	-
	5	-	-	Cooling Time Running	Just one start left	Num Starts Overrun	-	-	-
3	6	Extended diagnosis is available <sup>1)</sup> .	Parameter out of range	-	-	-	-	-	-
	7	Fault code. See section "Error Handling, Maintenance and Service-> Fault Messages" for a description of the code.							

<sup>1)</sup> There is more than one root cause that triggers this diagnosis. For details see diagnosis byte seven

<sup>2)</sup> By default these diagnosis bits are triggered from the digital inputs of the DX111/DX122 IO module. If you have created an own custom application these diagnosis bits might be triggered for other reasons (see handbook "Custom Application Editor" for more details).

---

# Universal Motor Controller

## UMC100-FBP

### Technical Description

---

#### Accessing Data on PROFIBUS

On PROFIBUS the device parameters, monitoring data and the command data size is described in the GSD file and mapped to the data telegrams cyclically exchanged between the PROFIBUS master and the UMC. The diagnosis data is transferred if needed via the extended PROFIBUS diagnosis also described in the GSD file. Device parameters are transferred in one block during bus start or UMC start from the PROFIBUS master to the UMC. See also the sections "Configuring the Fieldbus Configuration" and "Commissioning->Configuration from within the control system". The PROFIBUS plugs must meet at least the following requirements:

- PDP22 with index F or later (produced since 12/08)
- PDQ22 with index A6 or later (produced since 12/09)

#### Accessing Data on Modbus

On Modbus the data is provided in so-called registers. A Modbus master can read and write data on these registers. UMC data is accessible on the following registers:

Modbus Function Code	Register Address	Content
1	0x0000	Monitoring Data Bytes 0,1
3	0x0200 (hex)	Monitoring Data Words 1 - 7. Please note that words 6 and 7 contain binary data but are read as words!
15	0x0100 (hex)	Command Data Bytes 0,1,2,3
16	0x0300 (hex)	Command Data Words 1 - 5
3	0x2000 (hex)	Diagnosis Data Please note that diagnosis data is transmitted as words but contains bit information!

For more information about integrating the UMC in a Modbus network please refer to the MRP21-FBP (Modbus plug) technical manual.

#### Accessing Data on DeviceNet

On DeviceNet the device parameters, monitoring data and the command data size is described in the EDS file. Monitoring, command and diagnosis data is mapped to the data telegrams which are cyclically exchanged between the DeviceNet master and the UMC. For more information about device parameterisation in DeviceNet networks please refer to the DNP21-FBP (DeviceNet plug) technical manual.

#### Accessing Data on CANopen

On CANopen the device parameters, monitoring data and the command data size is described in the CANopen EDS file.

By default

- command data is mapped to RPDO1 for binary data and RPDO3 for analogue data.
- monitoring data is mapped to TPDO1 for binary byte 0 and 1
- analogue monitoring data words 1-5 are mapped to TPDO3/4 . In addition the remaining binary data (byte 12 - 15) are mapped to TPDO4 too!

Parameters can be set/read using SDO (Service Data Object) communication.

For more information about the CANopen FieldbusPlug please refer to the technical manual of COP21-FBP (CANopen plug).

# Universal Motor Controller

## UMC100-FBP

### Technical Description

#### Parameter Organisation

The UMC parameters are described in groups reflecting the major function blocks of the UMC. The figures in braces (e.g. 1.1) provide the link the menu structure i.e. where it is displayed.

- *Motor Management* lists all parameters related to motor management i.e. starting and stopping the motor and the control function
- *Protection* lists all parameters related to the motor itself (e.g. nominal current) and the motor protection functions
- *Communication* lists parameters related to the fieldbus communication
- *IO Module* lists all parameters related to the optional IO expansion modules
- *Display* lists all parameters directly related to the LCD panel
- *Function block* lists all parameters related to a specific function block.

The column "Adjustable via" shows the possible options to adjust a parameter. "All" means the parameter can be set via UMC100-PAN, GSD-PDP22, GSD-PDQ22, EDS CANopen, EDS DeviceNet and PBDM. Otherwise the available options are listed.

#### Motor Management Parameters

Parameter Number	Parameter	Description, Explanations	Options	Adjustable via
General motor management parameters				
20	Control function	Defines the type of starter function	Transparent (1), Overload relay (2), Direct starter (3), Reverse starter (4) Star-delta starter (5), Pole-changing starter (7), Actuator_1 (9), Actuator_2 (10), Actuator_3 (11), Actuator_4 (12)	All
21	Rev lock-out time	Interlocking time before a start command in the opposite direction is accepted	1-255 s	All
24	YD changeover mode	The UMC switches from star to delta either after a defined time or if the motor current has decreased to 90% of $I_{e1}$	Time (0), Current (1)	All
25	YD starting time (Time Limit Actuator)	Time switching from star to delta. If the changeover mode is set to 'current' this time defines when the motor current must be below 90% of $I_e$ . Set this parameter to at least 1s.  Defines the maximum travel time from one end position to the opposite end position.	1s to 360s in steps of 0,1s. Default: 60s  Unscaled: 10 ... 3600 Example: A value of 10 means 1s	All
27	Fault output	Behaviour of DO2 or DO3 in the event of a trip or fault.	Off (0), Flashing DO2 (1), On DO2 (2), Invert DO2 (3), Flashing DO3 (4), On DO3 (5), Invert DO3 (6)	All

# Universal Motor Controller

## UMC100-FBP

### Technical Description

#### Motor Management Parameters Continued

Parameter Number	Parameter	Description, Explanations	Options	Adjustable via
22	Checkback	Selection of the checkback supervision method.	Contact DI0 (1), <u>Current (2)</u> , Simulation (3)	All
86	Inching DI start input (Jog)	Enables inching (i.e. jogging) of the start signal originating from a digital input.	<u>No (0)</u> , Yes (1)	All
19	Enable custom logic	Enable the execution of a customer defined application	<u>No (0)</u> , Yes (1)	All
Local Control Mode 1				
90	Loc 1 start bus cyclic	Allow the motor to be started via cyclic bus command in local mode 1	<u>No (0)</u> , Yes (1)	All
91	Loc 1 stop bus cyclic	Allow the motor to be stopped via cyclic bus command in local mode 1	No (0), <u>Yes (1)</u>	
94	Loc1 start LCD	Allow the motor to be started via LCD panel in local mode 1	No (0), <u>Yes (1)</u>	
95	Loc1 stop LCD	Allow the motor to be stopped via LCD panel in local mode 1	No (0), <u>Yes (1)</u>	
96	Loc1 start bus acyclic	Allow the motor to be started via acyclic bus command in local mode 1 (e.g. from DTM)	<u>No (0)</u> , Yes (1)	
97	Loc1 stop bus acyclic	Allow the motor to be stopped via acyclic bus command in local mode 1 (e.g. from DTM)	No (0), <u>Yes (1)</u>	
92	Loc1 start DI	Allow the motor to be started via digital input in local mode 1	No (0), <u>Yes (1)</u>	
93	Loc1 stop DI	Allow the motor to be stopped via digital input in local mode 1	No (0), <u>Yes (1)</u>	
Local Control Mode 2				

# Universal Motor Controller

## UMC100-FBP

### Technical Description

#### Motor Management Parameters Continued

Parameter Number	Parameter	Description, Explanations	Options	Adjustable via
106	Loc 2 start bus cyclic	Allow the motor to be started via cyclic bus command in local mode 2	No (0), Yes (1)	All
107	Loc 2 stop bus cyc	Allow the motor to be stopped via cyclic bus command in local mode 2	No (0), Yes (1)	
110	Loc2 start LCD	Allow the motor to be started via LCD panel in local mode 2	No (0), Yes (1)	
111	Loc2 stop LCD	Allow the motor to be stopped via LCD panel in local mode 2	No (0), Yes (1)	
112	Loc2 start bus acyclic	Allow the motor to be started via acyclic bus command in local mode 2 (e.g. from DTM)	No (0), Yes (1)	
113	Loc2 stop bus acyc	Allow the motor to be stopped via acyclic bus command in local mode 2 (e.g. from DTM)	No (0), Yes (1)	
108	Loc2 start DI	Allow the motor to be started via digital input in local mode 2	No (0), Yes (1)	
109	Loc2 stop DI	Allow the motor to be stopped via digital input in local mode 2	No (0), Yes (1)	
<b>Auto Control Mode</b>				
98	Auto start bus cyclic	Allow to start the motor via cyclic bus command in auto mode	No (0), Yes (1)	All
99	Auto stop bus cyclic	Allow to stop the motor via cyclic bus command in auto mode	No (0), Yes (1)	
102	Auto start LCD	Allow to start the motor via LCD panel in auto mode	No (0), Yes (1)	
103	Auto stop LCD	Allow to stop the motor via LCD panel in auto mode	No (0), Yes (1)	
104	Auto start Bus Acyclic	Allow to start the motor via acyclic bus command in auto mode (e.g. from DTM)	No (0), Yes (1)	
105	Auto stop Bus Acyclic	Allow to stop the motor via acyclic bus command in auto mode (e.g. from DTM)	No (0), Yes (1)	
100	Auto start DI	Allow to start the motor via digital input in auto mode	No (0), Yes (1)	
101	Auto stop DI	Allow to stop the motor via digital input in auto mode	No (0), Yes (1)	

# Universal Motor Controller

## UMC100-FBP

### Technical Description

#### Motor Management Parameters Continued

Parameter Number	Parameter	Description, Explanations	Options	Adjustable via
Invert control (ctrl) Inputs				
82	Inv DI start input	If inverted (Yes) the DI is normally closed. If not inverted (No) it is normally open.	No (0), Yes (1)	All
83	Inv DI stop input	If inverted (Yes) the DI is normally closed. If not inverted (No) it is normally open.	No (0), Yes (1)	
Multifunction Inputs: The following parameters are all related to DI0-DI2 which are called multifunction inputs as their function can be adjusted in a wide range. (1.13)				
117, 118, 119	Multif. 0,1,2 delay	Delay until the function of DI0,1,2 is triggered	0...25,5 in steps of 0,1s Unscaled: 0...255 Example: A value of 5 means 500ms	All
120, 121, 122	Multif. 0,1,2 auto reset	If DI0,1,2 is configured as external fault an auto reset can be enabled.	No (0), Yes (1)	
135/136 137/138 139/140	Multif. 0,1,2 fault text Line 1, Line 2	If DI0,1,2 is configured as an external fault a text message can be defined which is shown on the LCD panel.	Line one and line two with 8 characters each. Default: „Fault Dlx“ where x=0,1,2	PBDTM, LCD Panel UMC100-PAN
114, 115, 116	Multifunction 0,1,2	Function of DI0/1/2. NC: Normally closed NO: Normally open  1) Motor running or stopped 2) Always when the motor is running	Off (0): Stop NC (1), Stop NO (2), Ext. Flt NC always <sup>1</sup> (3), Ext. Flt NO always <sup>1</sup> (4), Ext. Flt NC Motor on (5), Ext. Flt NO Motor on (6), Prep. emergency start NC (7), Prep. emergency start NO (8) Test position NC (9), Test position NO (10), Force local NC (11) Force local NO (12) Fault reset NC (13), Fault reset NO (14), Voltage DIP NC (15), Voltage DIP NO(16), CEM11 always <sup>2</sup> (Warn) (17), CEM11 after startup (Warn) (18), CEM11 always <sup>2</sup> (Fault) (19), CEM11 after startup (Fault) (20)	All
Extended				
23	Checkback time	The maximum delay between the output relay was closed until the checkback signal is present (signal at DI0 present or motor current > 20 % depending on parameter Checkback)	0.1, 0.2, 0.3, 0.4 ,0.5 ... 25.5 in steps of 0.1s Unscaled: 0...255 Example: A value of 5 means 500ms	All excluding GSD-PDQ22

# Universal Motor Controller

## UMC100-FBP

### Technical Description

#### Motor Management Parameters Continued

Parameter Number	Parameter	Description, Explanations	Options	Adjustable via
15	Emergency Start	To allow start-ups even if the thermal overload protection would prevent them.	Off (0), On (1)	All
14	Fault auto reset	Automatically reset of selected protection faults (PTC, overload (EOL), imbalance and phase loss).  Faults triggered from the UMC100 multifunction inputs and the IO module are not automatically reset. There are separate parameters.	Off (0), On (1)	All
81	Custom app parameter	Allows to specify a value which is available in the custom application.	0 ... 255	All
<b>Limit the Number of Starts</b>				
148	Num Starts Allowed	Defines the number of permissible starts in the time window.	0 ... 32 Zero switches off the start limit function.	All excluding GSD-PDQ22
149	Num Starts Window	Defines a time window in which only a certain number of starts are allowed.	0min ... 255min (4,25h) in steps of 1min Default value: 0	All excluding GSD-PDQ22
150	Num Starts Pause	After the motor was stopped a new start is not possible before the pause time is over. This parameter can be used independently of the other parameters i.e. without limiting the number of starts in a time window.	0min ... 255min (4,25h) in steps of 1min Default value: 0	All excluding GSD-PDQ22
155	Num Starts Overrun	Reaction if no start is left anymore but a start command was issued.	0: Disabled 1: Trip 2: Warning	All excluding GSD-PDQ22
221	Num Starts Prewarn	Reaction if only one start is left.	0: Disabled 1: Trip 2: Warning	All excluding GSD-PDQ22

# Universal Motor Controller

## UMC100-FBP

### Technical Description

#### Protection Parameters



Parameter Number	Parameter Name	Description, Explanations	Options	Adjustable via
Protection Parameters				
29	Setting $I_{e1}$	Nominal current of motor for speed 1.	0.24...3200A in steps of 0.01A Default: <u>0.50A</u>  Unscaled: 24...320000 Example: A value of 24 means 240mA	All
30	Setting $I_{e2}$	Nominal current of motor for speed 2.	See above	All
28	Trip class	Class according to EN/IEC 60947-4-1	Class 5 (0), Class 10 (1), Class 20 (2), Class 30 (3), Class 40 (4)	All
31	Current factor	Current factor when using an external CT or when the motor wires are fed through the UMC CTs more than once.	2,3,4,5, <u>100</u> ... 64000  Examples: •3: motor wires are fed through 3 times •100: internal CT, no multiple feed-throughs •12500 means a factor of 125:1	All
9	PTC, Thermistor	Setting for the built-in PTC (Thermistor) protection. The reaction to hardware cannot be set separately.	<u>Disabled (0)</u> , Trip(1), Warning(2)	All
48	Cooling mode	After a thermal overload trip which was triggered through the thermal motor model the cooling duration can be defined as fixed time or as a percentage of the thermal load level (0%=cold, 100% = trip)	<u>Time (0)</u> , Restart Level (1)	All
49	Cooling time	The time a restart is inhibited following a thermal overload trip triggered by the thermal motor model	30 ... 64000s Default value: 120s	All
50	Restart level in %	Below this threshold a motor restart is accepted.	10...100% Default value: <u>30%</u>	All excluding GSD-PDQ22

# Universal Motor Controller

## UMC100-FBP

### Technical Description

#### Protection Parameters Continued

Parameter Number	Parameter Name	Description, Explanations	Options	Adjustable via
146	Thermal load warning level	If the thermal model reaches the warning level a warning is generated.	20 ... <u>100</u>	All excluding GSD-PDQ22
Locked Rotor				
40	Locked rotor trip level	Current in percentage that should trigger a locked rotor fault during motor start-up. A value of 800% (160) switches off the function.	100% ... <u>800%</u> in steps of 5% 800% disables the function Unscaled: 20 ... 160 Example: 100 means 500%	All
41	Locked rotor trip delay	The time the motor current must exceed the adjusted threshold before a fault is triggered.	0, 0.1, 0.2, 0.3, 0.4, <u>0.5</u> ... 25.5s in steps of 0.1s Unscaled: 0...255 Example: 5 means 500ms	All
Phases				
42	Phase loss protection	Trips the motor depending of the trip class within 1.5 -12 seconds in case of a phase loss. This parameter must be set to On during regular operation.	Off (0), <u>On</u> (1)  Note: If the voltage module is present this parameter activates both voltage and current based phase loss detection.	All
43	Curr Imb Trip Level	Phase imbalance (current) trip threshold. Above this value a trip is generated. A value of 100 disables the trip.	0...100% 100% disables the function Default value: 50	All excluding GSD-PDQ22
44	Curr Imb Warn Level	Phase imbalance (current) warning threshold. Above this value a warning is generated. A value of 100 disables the warning.	0...100% 100% disables the function	All excluding GSD-PDQ22
45	Phase reversal	If enabled the three phases must be fed through the UMC CTs in the correct order (L1 left, L2 middle, L3 right).	<u>L1L2L3</u> (0), L3L2L1 (1)  Note: If the voltage module is present this parameter must not be changed.	All excluding GSD-PDQ22
46	Check phase sequence	Enables supervision of phase sequence (L1/L2/L3)	<u>Disabled</u> (0), Trip (1), Warning (2)  Note: If the voltage module is present this parameter activates both voltage and current based phase sequence protection.	All excluding GSD-PDQ22
Over - and Undercurrent				

# Universal Motor Controller

## UMC100-FBP

### Technical Description

#### Protection Parameters Continued

Parameter Number	Parameter Name	Description, Explanations	Options	Adjustable via
32	Low curr trip level	Value in % of $I/I_e$ . Below this value a trip is generated. A value of 0% disables the trip.	0...100% in steps of 5% Default: 0% 0% disables the function  Unscaled: 0 ... 20 Example: 10 means 50%	All
34	Low curr warn level	Value in % of $I/I_e$ . Below this value a warning is generated. A value of 0% disables the warning.	0...100% in steps of 5% Default: 50% 0% disables the function  Unscaled: 0...20 Example: 10 means 50%	All
33	Low curr trip delay	Delay time until a low current trip is triggered.	0...25.5s in steps of 0.1s Default: 0.5s  Unscaled: 0...255 Example: 20 means 2s	All excluding GSD-PDQ22
35	Low curr warn delay	Delay time until a low current warning is triggered.	0...25.5s in steps of 0.1s Default: 0.5s  Unscaled: 0...255 Example: 20 means 2s	All excluding GSD-PDQ22
36	High curr trip level	Value in % of $I/I_e$ . Above this value a trip is generated. A value of 800% (160) disables the trip.	100...800 in steps of 5% Default: 800% 800% disables the function  Unscaled: 20...160 Example: 100 means 500% (100% is nominal current)	All
38	High curr warn level	Value in % of $I/I_e$ . Above this value a warning is generated. A value of 800% (160) disables the warning	100...800% in steps of 5%. Default value is 150%. 800% disables the function  Unscaled: 20...160 Example: 100 means 500% (100% is nominal current)	All
37	High curr trip delay	Delay time until a high current trip is triggered..	0...25.5s in steps of 0.1s Default: 0.5s  Unscaled: 0...255 Example: 20 means 2s	All excluding GSD-PDQ22
39	High curr warn delay	Delay time until a high current warning is triggered.	0...25.5s in steps of 0.1s Default: 0.5s  Unscaled: 0...255 Example: 20 means 2s	All excluding GSD-PDQ22
Voltage Dip / Load Shedding				
142	Dip Enable	Enable / Disable function	Off (0), On (1), On + Rapid Cycle Lockout (2)	UMC100-PAN PBDTM

# Universal Motor Controller

## UMC100-FBP

### Technical Description

#### Protection Parameters Continued

143	Voltage Dip Duration	Max. voltage dip duration time before a trip is signalled.	0.1...25.5s in steps of 0.1s Default: 0.5s  Unscaled: 1...255 Example: 5 means 0.5s	All excluding GSD-PDQ22
144	Autorestart Window	If the voltage dip ends within this time window an autorestart is triggered (if enabled).	0.1 ... 1s in steps of 0.1s  Unscaled: 1...10 Example: 5 means 0.5s	UMC100-PAN PBDTM
145	Autorestart Delay	Delay until the motor is restarted	0 ... 255s	UMC100-PAN PBDTM
147	Enable Autorestart	Enables the autorestart of the motor after end of the voltage dip	Off (0) On (1)	UMC100-PAN PBDTM
156	Dip Restart Level	Voltage level indicating the end of the low voltage situation	50 ... 115% of $U_e$ in steps of 1%  Default value: 90	
157	Dip Level	Voltage level indicating a low voltage situation and triggering the DIP logic.	50 ... 115% of $U_e$ in steps of 1%  Default value: 70	
Internal Ground Fault				
10	Earth Fit Trip Level	Above this ground fault current a ground fault trip is triggered.  A value of 255 % disables the trip.	20 ... 80 in % of nominal current $I_{e1,2}$ (255 = off)  <b>Example:</b> $I_e = 100A$ , Earth Fit Trip Level = 35%. Then a earth fault current of 35A triggers a trip.	All
11	Earth Fit Trip Delay	Delay time until a ground fault trip is triggered.	0...25.5s in steps of 0.1s Default: 0,5s  Unscaled: 0...255 Example: 20 means 2s	All
12	Earth Fit Warn Level	Above this ground fault current a ground fault warning is triggered.  A value of 255% disables the warning.	20 ... 80 in % of nominal current $I_{e1,2}$ (255 = off)	All excluding GSD PDQ22
13	Earth Fit Warn Delay	Delay time until a ground fault warning is triggered.	0...25.5s in steps of 0.1s Default: 0,5s  Unscaled: 0...255 Example: 20 means 2s	All excluding GSD PDQ22
16	Earth Fit Detection	Defines when the internal ground fault protection function is active.	0: Always 1: <u>After Startup</u>	All

# Universal Motor Controller

## UMC100-FBP

### Technical Description

#### Communication Parameters

Parameter Number	Parameter Name	Description, Explanations	Options	Adjustable via
17	Address check	Enable check if bus address stored in the UMC is the same as the one stored in the FieldbusPlug.	<u>Off (0)</u> , On (1)	All
18	Busfault reaction	UMC behaviour in the event of a bus fault.	<u>Motor Off (0)</u> , Retain (1), Start For (2), Start Rev (3)	All
-	Bus address	Fieldbus address. Depending on the FieldbusPlug used, the permitted address range is smaller than the one allowed here.	0,1,2,3 ... <u>255</u>	UMC100-PAN PBDM
-	Parameter lock	Prevents any parameter changes if set to On.	<u>Unlocked (0)</u> , Locked (1)	UMC100-PAN

#### IO Module Parameters

##### DX111 / DX122 Parameters

Parameter Number	Parameter Name	Description, Explanations	Options	Adjustable via
8	Missing Module Reaction	Defines if the UMC creates a fault or a warning in case of a missing IO module.	<u>Error (0)</u> Warning (1)	All
1	DX1xx Enabled	Specify if the module is connected to UMC	<u>Off (0)</u> , On (1)	All
151	DX1xx DI delay	Input delay in ms assuming a line frequency of 50Hz	DX111: 3...200ms  Values are rounded up to the next multiple of 3. E.g.: 7,8,9 -> 9 ms delay  In addition to the software delay a fix hardware delay of about 4ms must be considered.  DX122: 3...200ms  Values are rounded to the next multiple of 10. Values below 20 are rounded up to 20. E.g.: 3...20: 20 ms delay 81...90: 90 ms delay	All excluding GSD-PDQ22
152	DX1xx AO type	Hardware type of the analogue output on the DX1xx module.	<u>0 - 20mA (0)</u> , 4 - 20mA (1), 0 - 10mA (2), 0 - 10V (3)	All excluding GSD-PDQ22
153	DX1xx AO error reaction	Reaction if the AO detects a short-circuit or wire break condition.	<u>Disabled (0)</u> , Trip (1), Warning (2)	All excluding GSD-PDQ22

# Universal Motor Controller

## UMC100-FBP

### Technical Description

#### VI150 / VI155 Parameters

Parameter Number	Parameter Name	Description, Explanations	Options	Adjustable via
4	VI15x Enabled	Specify if the module is connected to UMC	0: Off 1: On	All
158	Nominal Line Voltage	Line to Line Voltage e.g. 190V, 400V or 690V	$U_g$ : 150...690V in steps of 1V Default: 400V	All excluding GSD-PDQ22
159	U Low Trip Level	Value in % of $U/U_g$ . Below this value a trip is generated.	70 ... 100% 70 disables the function	All excluding GSD-PDQ22
160	U Low Trip Delay	Delay time until a low voltage trip is triggered.	0...25.5s in steps of 0.1s Default: 3s Unscaled: 0...255 Example: 20 means 2s	All excluding GSD-PDQ22
161	U Low Warn Level	Value in % of $U/U_g$ . Below this value a warning is generated.	70 ... 100% 70 disables the function	All excluding GSD-PDQ22
162	U Low Warn Delay	Delay time until a low voltage warning is triggered.	0...25.5s in steps of 0.1s Default: 3s Unscaled: 0...255 Example: 20 means 2s	All excluding GSD-PDQ22
163	U High Trip Level	Value in % of $U/U_g$ . Above this value a trip is generated.	100 ... 116% of $U_g$ in steps of 1% 116% disables the function	All excluding GSD-PDQ22
164	U High Trip Delay	Delay time until a high voltage trip is triggered.	0...25.5s in steps of 0.1s Default: 3s Unscaled: 0...255 Example: 20 means 2s	All excluding GSD-PDQ22
165	U High Warn Level	Value in % of $U/U_g$ . Above this value a warning is generated.	100 ... 116% of $U_g$ in steps of 1% 116% disables the function	All excluding GSD-PDQ22
166	U High Warn Delay	Delay time until a high voltage warning is triggered.	0...25.5s in steps of 0.1s Default: 3s Unscaled: 0...255 Example: 20 means 2s	All excluding GSD-PDQ22
200	PwrFactor Trip Level	Power factor (cos phi). Below this value a trip is generated. 30 disables the function	0.30 ... 1 in steps of 0.01 Unscaled: 30...100 Example: 75 means a PF of 0.75	All excluding GSD-PDQ22
201	PwrFactor Trip Delay	Delay time until a low power factor trip is triggered.	0...25.5s in steps of 0.1s Default: 3s Unscaled: 0...255 Example: 20 means 2s	All excluding GSD-PDQ22
202	PwrFactor Warn Level	Power factor (cos phi). Below this value a warning is generated. 30 disables the function	0.30 ... 1 in steps of 0.01 Unscaled: 30...100 Example: 75 means a PF of 0.75	All excluding GSD-PDQ22

# Universal Motor Controller

## UMC100-FBP

### Technical Description

#### VI150 / VI155 Parameters Continued

203	PwrFactor Warn Delay	Delay time until a low power factor warning is triggered	0...25.5s in steps of 0.1s Default: 3s Unscaled: 0...255 Example: 20 means 2s	All excluding GSD-PDQ22
204	U Imb. Trip Level	Voltage imbalance trip level 20 disables the function	0.2 ... 20% in steps of 0.1% Unscaled 2..200	All excluding GSD-PDQ22
205	U Imb. Trip Delay	Delay time until an imbalance trip is triggered	0...25.5s in steps of 0.1s Default: 1s Unscaled: 0...255 Example: 20 means 2s	All excluding GSD-PDQ22
206	U Imb. Warn Level	Voltage imbalance warning level 20 disables the function	0.2 ... 20% in steps of 0.1% Unscaled 2..200	All excluding GSD-PDQ22
207	U Imb. Warn Delay	Delay time until an imbalance warning is triggered	0...25.5s in steps of 0.1s Default: 1s Unscaled: 0...255 Example: 20 means 2s	All excluding GSD-PDQ22
208	P Low Trip Level	Below this value a trip is generated 20 disables the function	20 ... 100% in steps of 1%	All excluding GSD-PDQ22
209	P Low Trip Delay	Delay time until a low power trip is triggered	0...255s in steps of 1s Default: 5s	All excluding GSD-PDQ22
210	P Low Warn Level	Below this value a warning is generated. 20 disables the function	20 ... 100% in steps of 1%	All excluding GSD-PDQ22
211	P Low Warn Delay	Delay time until a low power warning is triggered	0...255s in steps of 1s Default: 5s	All excluding GSD-PDQ22
212	P High Trip Level	Above this value a trip is generated 200 (1000%) disables the function	100 ... 1000% in steps of 5% Unscaled: 20...200 Example: 20 means 100%	All excluding GSD-PDQ22
213	P High Trip Delay	Delay time until a high power trip is triggered	0...255s in steps of 1s Default: 10s	All excluding GSD-PDQ22
214	P High Warn Level	Above this value a warning is generated 200% (1000) disables the function	100 ... 1000% in steps of 5% Unscaled: 20...200 Example: 20 means 100%	All excluding GSD-PDQ22
215	P High Warn Delay	Delay time until a high power warning is triggered	0...255s in steps of 1s Default: 10s	All excluding GSD-PDQ22
216	Nominal Power Factor	Power factor value from the name plate or data sheet of the motor	0.01 ... 1 in steps of 0.01 Default: 1 Unscaled: 1...100 Example: 75 means a PF of 0.75	All excluding GSD-PDQ22

# Universal Motor Controller

## UMC100-FBP

### Technical Description

#### VI150 / VI155 Parameters Continued

217	Power Scale Factor	Factor that can be used to scale the active and apparent power so that the resulting value fits in a WORD. This is needed for bus transfer.	<p>0 = 1  <u>1 = 10</u>            2 = 100            3 = 1000</p> <p><b>Example:</b> <math>U_n</math> is 400V, <math>I_n</math> is 200A, Rated PF is 0,8.            The nominal active power is then <math>400 \cdot 200 \cdot 1,73 \cdot 0,8 = 110720</math>.            To transfer this value via fieldbus it must be scaled e.g. by 10. So the resulting value is <math>110720/10 = 11072</math> which fits in a WORD.</p>	All excluding GSD-PDQ22
219	THD Warning Level	Above this level of Total Harmonic Distortions a warning is triggered	3 ... <u>10%</u> in steps of 1% 10 disables the function	All excluding GSD-PDQ22
222	THD Warning Delay	Delay time until an warning is triggered	0 ... 255 s in steps of 1s Default is 5s	All excluding GSD-PDQ22
220	Load Startup Delay	Delay time until load (e.g. pump) has started up and power supervision functions should become active.	<u>0</u> ... 255 s in steps of 1s	All excluding GSD-PDQ22

# Universal Motor Controller

## UMC100-FBP

### Technical Description

#### UMC Display Parameters

Parameter Number	Parameter Name	Description, Explanations	Options	Adjustable via
123	Language	Language used on the LCD panel	English (0), German (1), ...	All
124	Tagname	String that is displayed on the LCD panel	String with 8 chars. Default: "UMC"	PBDTM UMC100-PAN
125	Backlight	LCD backlight	Off (0), On (1)	All excluding GSD-PDQ22
128	User display 1	Process value shown on the top level menu.	Thermal Load (0) DX1xx DI (1) DX1xx DO (2) Operating Hours (3) Number of Trips(4) Number of Starts (5) Max. Startup Current (6) Real Startup Time (7)	All excluding GSD-PDQ22
129	User display 2	Process value shown on the top level menu.	see above (default is 'Max startup current')	
130	User display 3	Process value shown on the top level menu.	see above (default is 'Real startup time')	
131	User display 4	Process value shown on the top level menu.	Binary 1 (0) Binary 2 (1) Analog 1 (2) Analog 2 (3) Time to Trip (4) Time to Cool (5)	
132	User display 5	Process value shown on the top level menu.	see 'User display 4'. Default is 'Time to Cool'.	
133	User display 4 text	See custom application manual for more details.	Text string with 8 characters describing the displayed value (default text 'TTT')	PBDTM UMC100-PAN
134	User display 5 text	See custom application manual for more details.	Text string with 8 characters describing the displayed value (default text 'TTC')	
Password Protection				
126	Password Protection	Enables the motor control / parameters to be password-protected	Off (0), On for Parameters (1), On for Param. + Motor Control (2)	All excluding GSD-PDQ22
-	Change Password	Password that permits parameters to be changed	0000 ... 9999	UMC100-PAN PBDTM

# Universal Motor Controller

## UMC100-FBP

### Technical Description

#### Function Block Related Parameters

##### Aux Input Block

In the standard built-in applications the inputs of this function block are connected to the digital inputs of the DX1xx module (see section 'Using Expansion Modules').

Parameter Number	Parameter Name	Description, Explanation	Options	Adjustable via
51 - 56	Aux inp 1-6 ack mode	Definition of the fault reset behavior	Manual Reset (0) Auto Reset (1)	All
57 - 61	Aux Inp 1-6 reaction	Definition of the input function  NC: Normally closed NO: Normally open	Disabled (0) Fault (NC) Motor in On/Off (1) Fault (NO) Motor in On/Off (2) Fault (NC) Motor in On (3) Fault (NO) Motor in On (4) Warning (NC) Motor in On/Off (5) Warning (NO) Motor in On/Off (6) Warning (NC) Motor in On (7) Warning (NO) Motor in On (8)	All
63/64 65/66 67/68 69/70 71/72 73/74	Aux Inp 1-6 message Line 1/Line 2	Message text line 1 and line 2	Free text with 8 characters for each line. Default: „Aux Dlx“ with x=1...6	DTM, UMC100-PAN
75 - 80	Aux Inp 1-6 delay	Input delay time in multiples of 100ms	0 ... 255 in multiples of 0.1s  Example: A value of 5 means 500ms	All excluding GSD-PDQ22

# Universal Motor Controller

## UMC100-FBP

### Technical Description

#### All Parameters Sorted by Parameter Number

No	Name	Parameter Group
1	DX1xx Enabled	IO Module Parameters
4	VI15x Enabled	IO Module Parameters
8	Missing Module React.	IO Module Parameters
9	PTC, Thermistor	Protection
10	Earth Flt Trip Level	Protection
11	Earth Flt Trip Delay	Protection
12	Earth Flt Warn Level	Protection
13	Earth Flt Warn Delay	Protection
14	Fault Auto Reset	Motor Management
15	Emergency Start	Motor Management
16	Earth Flt Detection	Protection
17	Address Check	Communication
18	Busfault Reaction	Communication
19	Enable Custom Logic	Motor Management
20	Control Function	Motor Management
21	Rev Lock-Out Time	Motor Management
22	Checkback	Motor Management
23	Checkback Time	Motor Management
24	YD Change-Over Mode	Motor Management
25	YD Starting Time	Motor Management
27	Fault Output	Motor Management
28	Trip Class	Protection
29	Setting Ie 1	Protection
30	Setting Ie 2	Protection
31	Current Factor	Protection
32	Low Curr Trip Level	Protection
33	Low Curr Trip Delay	Protection
34	Low Curr Warn Level	Protection
35	Low Curr Warn Delay	Protection
36	High Curr Trip Level	Protection
37	High Curr Trip Delay	Protection
38	High Curr Warn Level	Protection
39	High Curr Warn Delay	Protection
40	Locked Rotor Level	Protection
41	Locked Rotor Delay	Protection
42	Phase Loss Prot.	Protection
43	Current Imb Trip Level	Protection
44	Current Imb Warn Level	Protection
45	Phase Reversal	Protection
46	Check Phase Sequence	Protection
48	Cooling Mode	Protection
49	Cooling Time	Protection
50	Restart Level	Protection

No	Name	Parameter Group
51	Aux Inp 1 Ack Mode	Aux Input Block
52	Aux Inp 2 Ack Mode	Aux Input Block
53	Aux Inp 3 Ack Mode	Aux Input Block
54	Aux Inp 4 Ack Mode	Aux Input Block
55	Aux Inp 5 Ack Mode	Aux Input Block
56	Aux Inp 6 Ack Mode	Aux Input Block
57	Aux Inp 1 Reaction	Aux Input Block
58	Aux Inp 2 Reaction	Aux Input Block
59	Aux Inp 3 Reaction	Aux Input Block
60	Aux Inp 4 Reaction	Aux Input Block
61	Aux Inp 5 Reaction	Aux Input Block
62	Aux Inp 6 Reaction	Aux Input Block
63	Aux Inp 1 Message L1	Aux Input Block
64	Aux Inp 1 Message L2	Aux Input Block
65	Aux Inp 2 Message L1	Aux Input Block
66	Aux Inp 2 Message L2	Aux Input Block
67	Aux Inp 3 Message L1	Aux Input Block
68	Aux Inp 3 Message L2	Aux Input Block
69	Aux Inp 4 Message L1	Aux Input Block
70	Aux Inp 4 Message L2	Aux Input Block
71	Aux Inp 5 Message L1	Aux Input Block
72	Aux Inp 5 Message L2	Aux Input Block
73	Aux Inp 6 Message L1	Aux Input Block
74	Aux Inp 6 Message L2	Aux Input Block
75	Aux Inp 1 Delay	Aux Input Block
76	Aux Inp 2 Delay	Aux Input Block
77	Aux Inp 3 Delay	Aux Input Block
78	Aux Inp 4 Delay	Aux Input Block
79	Aux Inp 5 Delay	Aux Input Block
80	Aux Inp 6 Delay	Aux Input Block
81	Custom App Parameter	Motor Management
82	Invert DI Start Inp.	Motor Management
83	Invert DI Stop Inp.	Motor Management
86	Inching DI Start Inp	Motor Management
90	Loc 1 Start Bus Cyc	Motor Management
91	Loc 1 Stop Bus Cyc	Motor Management
92	Loc 1 Start DI	Motor Management
93	Loc 1 Stop DI	Motor Management
94	Loc 1 Start LCD	Motor Management
95	Loc 1 Stop LCD	Motor Management
96	Loc 1 Start Bus Acyc	Motor Management
97	Loc 1 Stop Bus Acyc	Motor Management
98	Auto Start Bus Cyc	Motor Management
99	Auto Stop Bus Cyc	Motor Management
100	Auto Start DI	Motor Management

# Universal Motor Controller

## UMC100-FBP

### Technical Description

No	Name	Parameter Group
101	Auto Stop DI	Motor Management
102	Auto Start LCD	Motor Management
103	Auto Stop LCD	Motor Management
104	Auto Start Bus Acyc	Motor Management
105	Auto Stop Bus Acyc	Motor Management
106	Loc 2 Start Bus Cyc	Motor Management

No	Name	Parameter Group
107	Loc 2 Stop Bus Cyc	Motor Management
108	Loc 2 Start DI	Motor Management
109	Loc 2 Stop DI	Motor Management
110	Loc 2 Start LCD	Motor Management
111	Loc 2 Stop LCD	Motor Management
112	Loc 2 Start Bus Acyc	Motor Management
113	Loc 2 Stop Bus Acyc	Motor Management
114	Multif In 0	Motor Management
115	Multif In 1	Motor Management
116	Multif In 2	Motor Management
117	Multif In 0 Delay	Motor Management
118	Multif In 1 Delay	Motor Management
119	Multif In 2 Delay	Motor Management
120	Multif In 0 Autoreset	Motor Management
121	Multif In 1 Autoreset	Motor Management
122	Multif In 2 Autoreset	Motor Management
123	Language	Display
124	Tagname	Display
125	Backlight	Display
126	Password Protection	Display
128	User Display 1	Display
129	User Display 2	Display
130	User Display 3	Display
131	User Display 4	Display
132	User Display 5	Display
133	User Display 4 Text	Display
134	User Display 5 Text	Display
135	Multif In 0 Message L1	Motor Management
136	Multif In 0 Message L2	Motor Management
137	Multif In 1 Message L1	Motor Management
138	Multif In 1 Message L2	Motor Management
139	Multif In 2 Message L1	Motor Management
140	Multif In 2 Message L2	Motor Management
142	Dip Enable	Protection
143	Dip Duration	Protection
144	Dip Autorestart Window	Protection
145	Dip Autorestart Delay	Protection
146	Thermal Load Warnlev	Protection

No	Name	Parameter Group
147	Dip Autorestart Enable	Protection
148	Num Starts Interval	Motor Management
149	Num Starts Window	Motor Management
150	Num Starts Pause	Motor Management
151	DX1xx DI Delay	IO Module Parameters
152	DX1xx AO Type	IO Module Parameters
153	DX1xx AO Err Reac	IO Module Parameters
155	Num Starts Overrun	Motor Management
156	Dip Restart Level	Protection
157	Dip Level	Protection
158	Nominal Line Voltage	Protection
159	U Low Trip Level	Protection
160	U Low Trip Delay	Protection
161	U Low Warn Level	Protection
162	U Low Warn Delay	Protection
163	U High Trip Level	Protection
164	U High Trip Delay	Protection
165	U High Warn Level	Protection
166	U High Warn Delay	Protection
200	PwrFactor Trip Level	Protection
201	PwrFactor Trip Delay	Protection
202	PwrFactor Warn Level	Protection
203	PwrFactor Warn Delay	Protection
204	U Imb. Trip Level	Protection
205	U Imb. Trip Delay	Protection
206	U Imb. Warn Level	Protection
207	U Imb. Warn Delay	Protection
208	P Low Trip Level	Protection
209	P Low Trip Delay	Protection
210	P Low Warn Level	Protection
211	P Low Warn Delay	Protection
212	P High Trip Level	Protection
213	P High Trip Delay	Protection
214	P High Warn Level	Protection
215	P High Warn Delay	Protection
216	Nominal Power Factor	Protection
217	Power Scale Factor	Protection
218	Pulse After x kWh	Protection
219	THD Warning Level	Protection
220	Load Startup Delay	Protection
221	Num Starts Prewarn	Protection
222	THD Warning Delay	Protection
1000	Parameter Lock	Communication
1001	Busaddress	Communication

# Universal Motor Controller

## UMC100-FBP

### Technical Description

#### All Parameters Sorted Alphabetically

No	Name	Parameter Group
17	Address Check	Communication
104	Auto Start Bus Acyc	Motor Management
98	Auto Start Bus Cyc	Motor Management
100	Auto Start DI	Motor Management
102	Auto Start LCD	Motor Management
105	Auto Stop Bus Acyc	Motor Management
99	Auto Stop Bus Cyc	Motor Management
101	Auto Stop DI	Motor Management
103	Auto Stop LCD	Motor Management
51	Aux Inp 1 Ack Mode	Aux Input Block
75	Aux Inp 1 Delay	Aux Input Block
63	Aux Inp 1 Message L1	Aux Input Block
64	Aux Inp 1 Message L2	Aux Input Block
57	Aux Inp 1 Reaction	Aux Input Block
52	Aux Inp 2 Ack Mode	Aux Input Block
76	Aux Inp 2 Delay	Aux Input Block
65	Aux Inp 2 Message L1	Aux Input Block
66	Aux Inp 2 Message L2	Aux Input Block
58	Aux Inp 2 Reaction	Aux Input Block
53	Aux Inp 3 Ack Mode	Aux Input Block
77	Aux Inp 3 Delay	Aux Input Block
67	Aux Inp 3 Message L1	Aux Input Block
68	Aux Inp 3 Message L2	Aux Input Block
59	Aux Inp 3 Reaction	Aux Input Block
54	Aux Inp 4 Ack Mode	Aux Input Block
78	Aux Inp 4 Delay	Aux Input Block
69	Aux Inp 4 Message L1	Aux Input Block
70	Aux Inp 4 Message L2	Aux Input Block
60	Aux Inp 4 Reaction	Aux Input Block
55	Aux Inp 5 Ack Mode	Aux Input Block
79	Aux Inp 5 Delay	Aux Input Block
71	Aux Inp 5 Message L1	Aux Input Block
72	Aux Inp 5 Message L2	Aux Input Block
61	Aux Inp 5 Reaction	Aux Input Block
56	Aux Inp 6 Ack Mode	Aux Input Block
80	Aux Inp 6 Delay	Aux Input Block
73	Aux Inp 6 Message L1	Aux Input Block
74	Aux Inp 6 Message L2	Aux Input Block
62	Aux Inp 6 Reaction	Aux Input Block
125	Backlight	Display
1001	Busaddress	Communication
18	Busfault Reaction	Communication
46	Check Phase Sequence	Protection
22	Checkback	Motor Management
23	Checkback Time	Motor Management

20	Control Function	Motor Management
48	Cooling Mode	Protection
49	Cooling Time	Protection
31	Current Factor	Protection
43	Curr Imb Trip Level	Protection
44	Curr Imb Warn Level	Protection
81	Custom App Parameter	Motor Management
145	Dip Autorestart Delay	Protection
147	Dip Autorestart Enable	Protection
144	Dip Autorestart Window	Protection
143	Dip Duration	Protection
142	Dip Enable	Protection
157	Dip Level	Protection
156	Dip Restart Level	Protection
153	DX1xx AO Err Reac	IO Module Parameters
152	DX1xx AO Type	IO Module Parameters
151	DX1xx DI Delay	IO Module Parameters
1	DX1xx Enabled	IO Module Parameters
15	Emergency Start	Motor Management
19	Enable Custom Logic	Motor Management
14	Fault Auto Reset	Motor Management
27	Fault Output	Motor Management
37	High Curr Trip Delay	Protection
36	High Curr Trip Level	Protection
39	High Curr Warn Delay	Protection
38	High Curr Warn Level	Protection
86	Inching DI Start Inp	Motor Management
82	Invert DI Start Inp.	Motor Management
83	Invert DI Stop Inp.	Motor Management
123	Language	Display
220	Load Startup Delay	Protection
96	Loc 1 Start Bus Acyc	Motor Management
90	Loc 1 Start Bus Cyc	Motor Management
92	Loc 1 Start DI	Motor Management
94	Loc 1 Start LCD	Motor Management
97	Loc 1 Stop Bus Acyc	Motor Management
91	Loc 1 Stop Bus Cyc	Motor Management
93	Loc 1 Stop DI	Motor Management
95	Loc 1 Stop LCD	Motor Management
112	Loc 2 Start Bus Acyc	Motor Management
106	Loc 2 Start Bus Cyc	Motor Management
108	Loc 2 Start DI	Motor Management
110	Loc 2 Start LCD	Motor Management

# Universal Motor Controller

## UMC100-FBP

### Technical Description

113	Loc 2 Stop Bus Acyc	Motor Management
107	Loc 2 Stop Bus Cyc	Motor Management
109	Loc 2 Stop DI	Motor Management
111	Loc 2 Stop LCD	Motor Management
41	Locked Rotor Delay	Protection
40	Locked Rotor Level	Protection
33	Low Curr Trip Delay	Protection
32	Low Curr Trip Level	Protection
35	Low Curr Warn Delay	Protection
34	Low Curr Warn Level	Protection
8	Missing Module React.	IO Module Parameters
114	Multif In 0	Motor Management
120	Multif In 0 Autoreset	Motor Management
117	Multif In 0 Delay	Motor Management
135	Multif In 0 Message L1	Motor Management
136	Multif In 0 Message L2	Motor Management
115	Multif In 1	Motor Management
121	Multif In 1 Autoreset	Motor Management
118	Multif In 1 Delay	Motor Management
137	Multif In 1 Message L1	Motor Management
138	Multif In 1 Message L2	Motor Management
116	Multif In 2	Motor Management
122	Multif In 2 Autoreset	Motor Management
119	Multif In 2 Delay	Motor Management
139	Multif In 2 Message L1	Motor Management
140	Multif In 2 Message L2	Motor Management
158	Nominal Line Voltage	Protection
216	Nominal Power Factor	Protection
148	Num Starts Allowed	Motor Management
155	Num Starts Overrun	Motor Management
150	Num Starts Pause	Motor Management
221	Num Starts Prewarn	Motor Management
149	Num Starts Window	Motor Management
1000	Parameter Lock	Communication
126	Password Protection	Display
43	Phase Imb Trip Level	Protection
44	Phase Imb Warn Level	Protection
42	Phase Loss Prot.	Protection
45	Phase Reversal	Protection
9	PTC, Thermistor	Protection
200	PwrFactor Trip Level	Protection
201	PwrFactor Trip Delay	Protection
202	PwrFactor Warn Level	Protection
203	PwrFactor Warn Delay	Protection
212	P High Trip Level	Protection
213	P High Trip Delay	Protection

214	P High Warn Level	Protection
215	P High Warn Delay	Protection
208	P Low Trip Level	Protection
209	P Low Trip Delay	Protection
210	P Low Warn Level	Protection
211	P Low Warn Delay	Protection
50	Restart Level	Protection
21	Rev Lock-Out Time	Motor Management
29	Setting Ie 1	Protection
30	Setting Ie 2	Protection
124	Tagname	Display
146	Thermal Load Warnlev	Protection
219	THD Warning Level	Protection
222	THD Warning Delay	Protection
28	Trip Class	Protection
159	U Low Trip Level	Protection
160	U Low Trip Delay	Protection
161	U Low Warn Level	Protection
162	U Low Warn Delay	Protection
163	U High Trip Level	Protection
164	U High Trip Delay	Protection
165	U High Warn Level	Protection
166	U High Warn Delay	Protection
204	U Imb. Trip Level	Protection
205	U Imb. Trip Delay	Protection
206	U Imb. Warn Level	Protection
207	U Imb. Warn Delay	Protection
128	User Display 1	Display
129	User Display 2	Display
130	User Display 3	Display
131	User Display 4	Display
133	User Display 4 Text	Display
132	User Display 5	Display
134	User Display 5 Text	Display
24	YD Change-Over Mode	Motor Management
25	YD Starting Time	Motor Management

# Universal Motor Controller UMC100-FBP Technical Description

## A2 Circuit Diagrams with Emergency Stop Function

### Direct Starter, Category 4

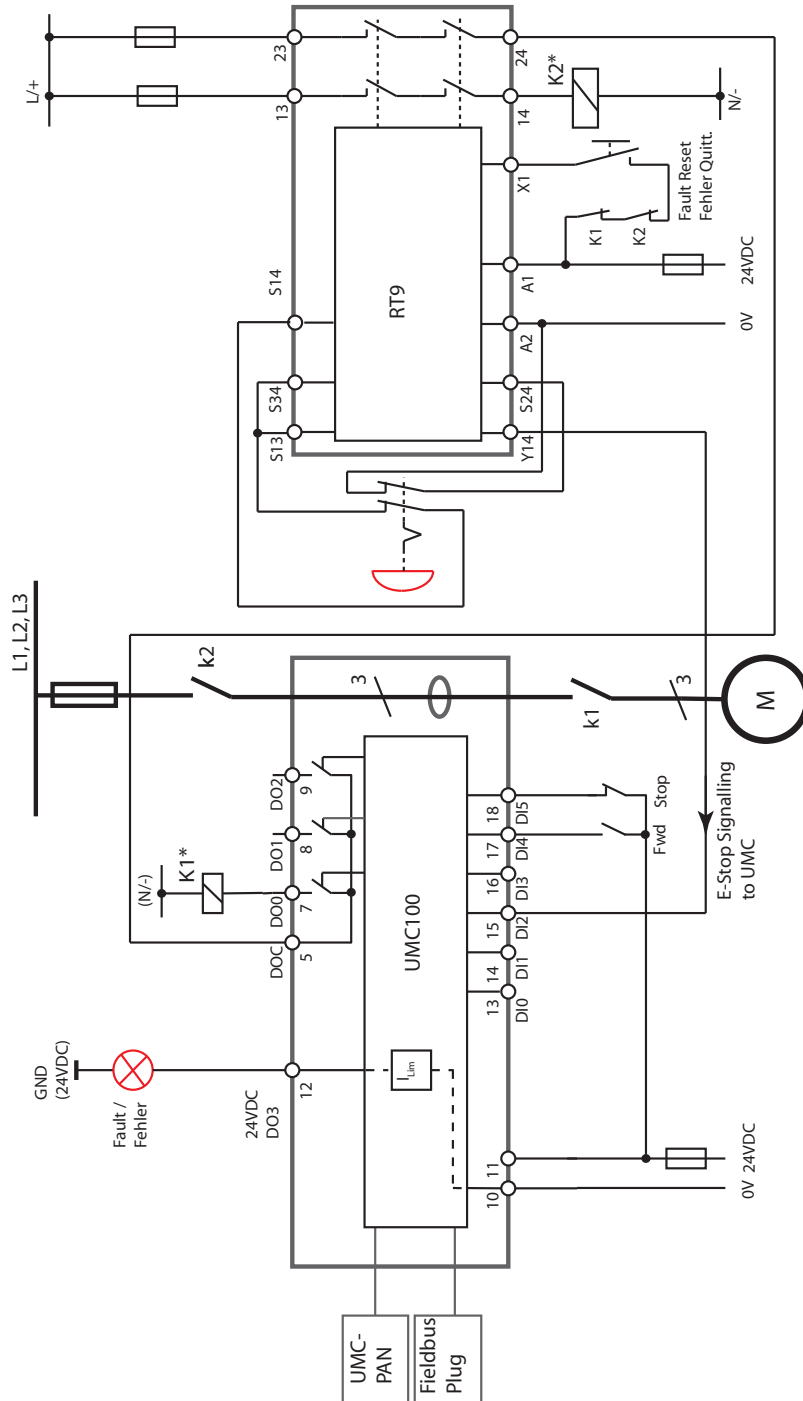

Circuit diagram showing safe-tripping with the help of an emergency stop relay. Carefully read the RT9 manual on how to use this device.

\*) Use spark suppression for larger contactors and also interface relays to maintain the service life of the UMC100 and RT9 internal relays.



# Universal Motor Controller

## UMC100-FBP

### Technical Description

#### A3 Technical Data

##### UMC100

<b>Main Power Lines</b>	
Voltage (three-phase systems)	<p>Max. 1000 V AC</p> <p>Attention: For an <math>U_{imp}</math> of 8 kV and a voltage of 1000 V the device must be used according to Annex H EN60947-1 in the range <math>600\text{ V} &lt; U_e \leq 1000\text{ V}</math>.</p> <p>(IT Network) only for overvoltage category II. Otherwise overvoltage category III applies.</p> <p>For voltages &gt; 690V isolated wires have to be used.</p>
Conductor holes in the current transformers	Max. diameter 11 mm incl. cable isolation
Set current range for overload protection	<p>UMC alone: 0.24 - 63 A</p> <p>UMC with provided current transformer: 60 - 850 A (see chapter 'Connecting External Current Transformers')</p> <p>Wire size has to be fixed acc. to IEC/EN 60204</p>
Overload protection for three-phase motors	Acc. to EN/IEC 60947-4-1
Trip classes, selectable by parameter For trip class 40E selecting the contactor and the protective elements with special care!	5E, 10E, 20E, 30E, 40E (acc. to EN/IEC 60947-4-1)
Tolerance of tripping time (incl. total ranges of current, temperature 0-60°C, frequency 45-65 Hz)	<p>UMC alone: +/- 10 %</p> <p>UMC with provided current transformer: +/- 14 %</p>
Tolerance of phase imbalance	+/- 10 %
Tripping time for phase loss	Trip class: 5 approx. 1.5 s 10 approx. 3 s 20 approx. 6 s 30 approx. 9 s 40 approx. 12 s
Accuracy of current measurement (range 50 to 200 % of $I_e$ with $I_e > 0.5A$ )	<p>UMC alone 3%</p> <p>UMC with provided external current transformer: 4%</p>
Load per phase:	Approx. 30 mΩ
Frequency range	45 - 65 Hz. Protection of frequency converters is not allowed.
Short-circuit protection	Provided by external short-circuit protection device), e. g. MO, MCB, MCCB or fuse. Refer also to ABB coordination tables available here: <a href="http://www.abbcontrol.fr/coordination_tables/TABLES5.asp">http://www.abbcontrol.fr/coordination_tables/TABLES5.asp</a>
Cross-section of lines	Acc. to the rated motor current referring EN/IEC 60947-1 and the specific installation condition in EN/IEC 60204 or VDE 298-4 resp.
Vibration according IEC 60068-2-6 Shock according IEC 60068-2-27	<p>5 g (without LCD Panel)</p> <p>15 g / 11 ms</p>

# Universal Motor Controller

## UMC100-FBP

### Technical Description

#### Tripping time for warm motor for 3-phase symmetrical loads

(Motor current  $I_c/I_e = 100\%$  for long time before overloading)

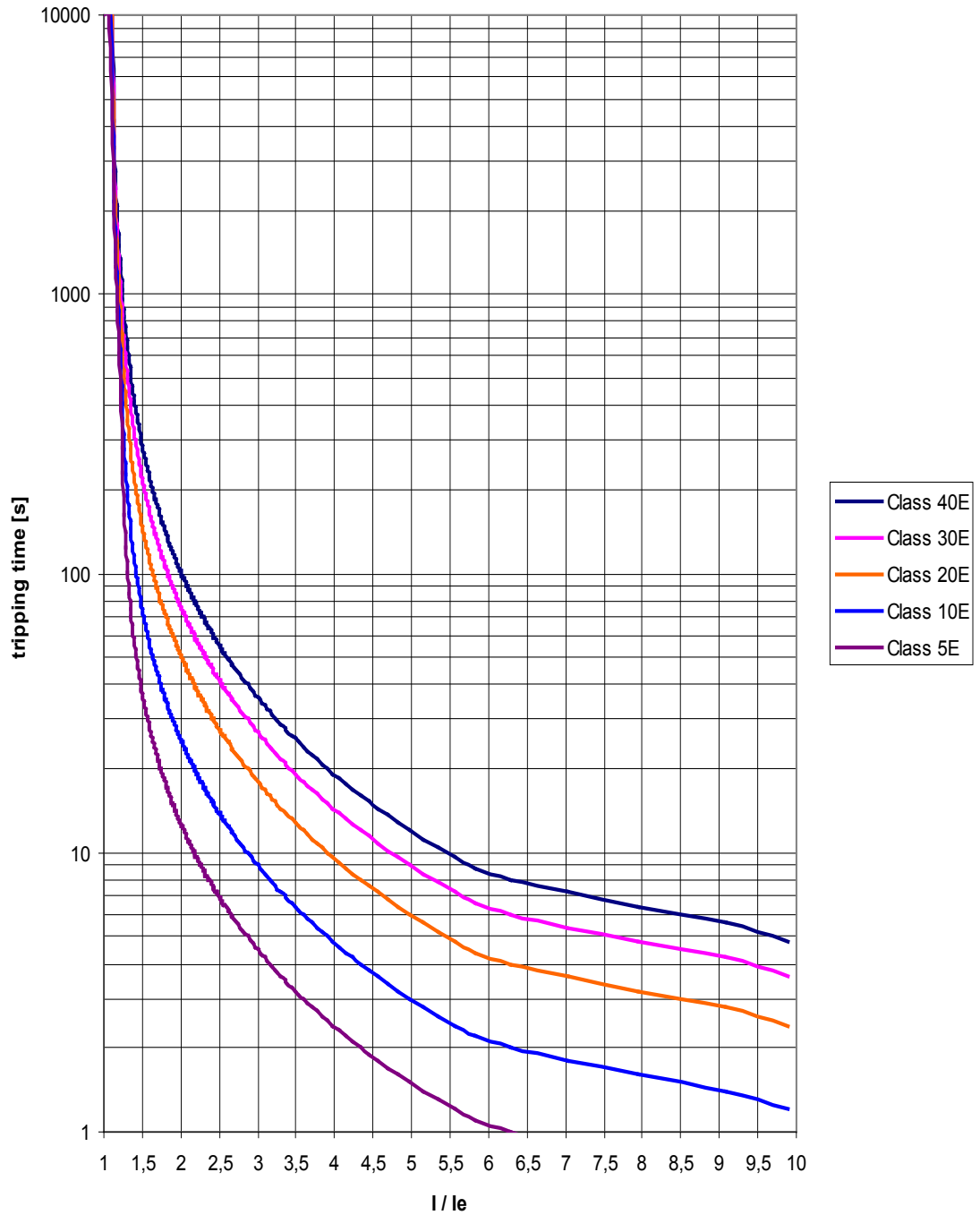

# Universal Motor Controller

## UMC100-FBP

### Technical Description

#### Tripping time for cold motor for 3-phase symmetrical loads

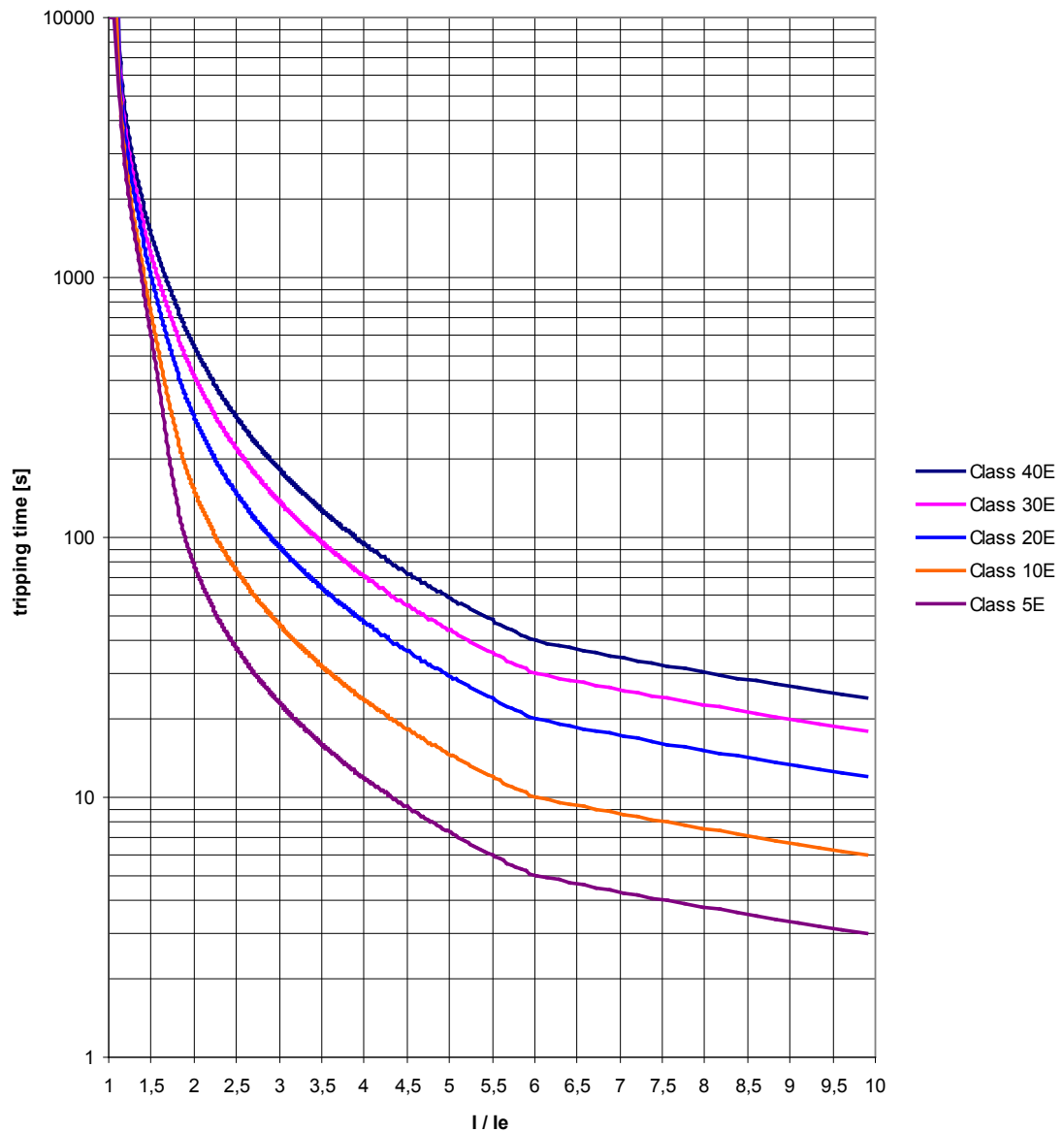

Performance under short circuit conditions. Coordination type 2 I <sub>q</sub> : Rated conditional short circuit current.	I <sub>q</sub>	100 kA	50 kA	100 kA
	U <sub>p</sub>	690 V AC	1000 V AC	600 V AC
	Fuse	200 A gG	200 A gG	300A RK5

Controller Unit	
Supply voltage	24 V DC (+30 % ... -20 %) (19.2 ... 31.2 V DC) including ripple
Supply current (incl. DIs, relays activated, transistor output loaded with 200 mA)	Max. 360 mA (at 19.2 ... 31.2 V DC)
Total power dissipation	Max. 9 W
Reverse polarity protection	Yes
LEDs: Red/yellow/green	Red: Motor has been tripped due to a thermal overload condition or another fault. Yellow: Motor is running Green: Ready for operation

# Universal Motor Controller

## UMC100-FBP

### Technical Description

<b>Digital Inputs</b>	
Number of digital inputs	6 (DI0 ... DI5) Type 1 accord. to EN 61131-2
Supply for digital inputs	24 V DC
Isolation	No
Input signal bounce suppression	Typ. 2 ms
Signal 0 range including ripple	-31.2 ... +5 V
Signal 1 range including ripple	+15 ... +31.2 V
Input current per channel (24 V DC)	Typ. 6.0 mA
Input resistor to 0 V	3.9 kΩ
Cable length	unshielded max. 600 m shielded max. 1000 m

<b>Relay Outputs</b>	
Number of relay outputs	3 x monostable with one common root
Voltage range of contacts	12 - 250 V AC/DC
Lowest switched power for correct signals	1 W or 1 VA
Switching capacity per relay contact acc. to EN 60947-5-1 (electromagnetic load)	AC-15 240 V AC: max. 1,5 A AC-15 120 V AC: max. 3 A DC-13 250 V DC max. 0.11 A DC-13 125 V DC max. 0.22 A DC-13 24 V DC max. 1 A
Short-circuit protection	6 A gG
Uimp	4 kV
Switching of inductive power	Inductive loads need additional measures for spark suppression. Diodes for DC voltage and varistors / RC elements for AC voltage are suitable. Some DC coil contactors contain rectifiers which suppress sparks perfectly.
Relay contact service life	Mechanical 500 000 switching cycles  Electrical (250 V AC): 0.5 A: 100 000 cycles 1.5 A 50 000 switching
Internal clearance and creepage distances relay contacts to 24 V circuits	> 5.5 mm (safety insulation up to 250 V AC) (EN 60947-1, Pollution degree 2)
Pollution degree terminals	3
Supply power down/up, behaviour: Valid for all motor control functions, but not for transparent and overload relay.	Whenever the supply voltage of the UMC is switched off and on, the starting of the motor needs a new RUN signal.

<b>Digital Output</b>	
Max. output current	200 mA
Short circuit protected	Yes
Output voltage if high	UMC100 supply voltage, nominal 24 V DC
Isolation	No

<b>Thermistor Motor Protection (PTC - binary) Type A</b>	
Broken wire resistance	> 4.8 kΩ
Voltage at broken wires between terminals T1/T2	12 V DC (typ.)
Response resistance	3.4 - 3.8 kΩ
Reset resistance	1.5 - 1.65 kΩ

# Universal Motor Controller

## UMC100-FBP

### Technical Description

<b>Thermistor Motor Protection (PTC - binary) Type A</b>	
Short circuit resistance Current at short circuit conditions	< 21 $\Omega$ 1.5 mA (typ.)
Response time	800 ms
Max. cold resistance of PTC sensor chain	< 1.5 k $\Omega$
Line length	2.5 mm <sup>2</sup> : 2 x 250 m 1.5 mm <sup>2</sup> : 2 x 150 m 0.5 mm <sup>2</sup> : 2 x 50 m
Isolation	No

<b>Fieldbus Connection</b>	
Mounting	Plug connection, fastening with supplied screw
Tightening torque of the fixing screw	0.8 Nm + rotation 90 degree
Suitable ABB FieldBusPlug types for	PROFIBUS: PDP22-FBP or PDQ22 Modbus: MRP21 DeviceNet: DNR21 CANopen: COP21

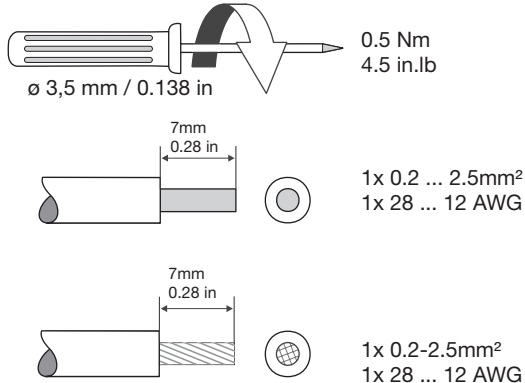
<b>Environmental and mechanical data</b>	
Mounting	On DIN rail (EN 50022-35) or with 4 screws M4
Mounting position	Any
Dimensions (W x H x D)	70 x 105 x 110 mm (incl. FieldBusPlug and Control Panel)
Net weight	0.28 kg (current transformer + controller unit)
Wire size and tightening torque	 <p>0.5 Nm 4.5 in.lb</p> <p><math>\varnothing</math> 3,5 mm / 0.138 in</p> <p>7mm 0.28 in</p> <p>1x 0.2 ... 2.5mm<sup>2</sup> 1x 28 ... 12 AWG</p> <p>7mm 0.28 in</p> <p>1x 0.2-2.5mm<sup>2</sup> 1x 28 ... 12 AWG</p>
Tightening torque for screw mounting	0.8 Nm
Degree of protection	UMC: IP20
Temperature range	Storage -25 ... +70 °C Operation 0 ... +60 °C
Marks, Approvals	CE, cUL, GL, further in preparation. Ask your local sales representative for other approvals.

# Universal Motor Controller

## UMC100-FBP

### Technical Description

#### Performance Data

Reaction time UMC100 DI to UMC100 Relay Output (incl. hardware delays).	typ. 10 ms (Transparent Control Function)
Reaction time UMC100 DI to DX111 Relay Output (incl. hardware delays)	typ. 10 ms (Transparent Control Function)
Reaction time from DX111 DI to UMC100 Relay Output (incl. hardware delays)	typ. 14 ms (Transparent Control Function)
Number of supported function blocks:	See 2CDC 135 014 D02xx

#### UMC100-PAN

Installation	Installation in a switchgear cabinet door or on a front panel.
Degree of protection	IP54 (on front side)
LEDs: Red/Yellow/Green	By default the LEDs have the same meaning as the ones on the UMC100.  Red: Error Yellow: Motor is running Green: Ready for operation
Buttons	6 buttons with fixed meaning
Dimensions (WxHxD)	50 x 66 x 15 mm
Net weight	0,04 kg
Temperature range	Storage -25 ... +70 °C Operation 0 ... +55 °C
Tightening Torque for screw mounting	0.5 Nm

#### DX111 and DX122

<b>General</b>	
Mounting	Snap-on mounting onto 35 mm standard mounting rails
Mounting position	Any
Dimensions (W x H x D)	45 x 77 x 100 mm (excluding communication connector)
LEDs: Red/yellow/green	Red: Hardware error of module Yellow: Diagnosis available Green: Ready for operation
Supply voltage	24 V DC (+30 % ... -20 %) (19.2 ... 31.2 V DC) including ripple
Supply current	Max. 90 mA (at 19.2 ... 31.2 V DC)

# Universal Motor Controller

## UMC100-FBP

### Technical Description

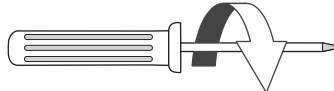
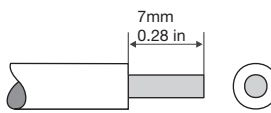
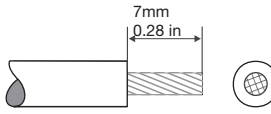
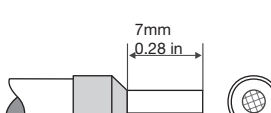
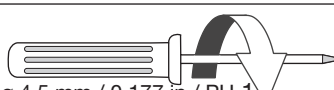
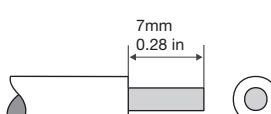
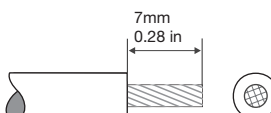
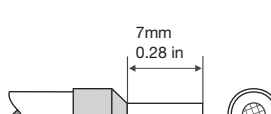
General	
Tightening torque for the communication terminals	 0.22 Nm ø 1.5 mm   
Tightening torque for the input, output and supply terminals	 0.6 ... 0.8 Nm 5.31 ... 7.08 in.lb ø 4,5 mm / 0.177 in / PH 1   
Net weight	0.22 kg
Degree of protection	IP20
Temperature range	storage -25 ... +70 °C operation 0 ... +55 °C (DX122) / +60 °C (DX111)
Marks, Approvals	CE, cUL Further in preparation. Ask your local sales representative for other marks/approvals.

Relay Outputs	
Number of relay outputs	4 1DO1, 1DO2 with root 1DOC 2DO3, 2DO4 with root 2DOC
Voltage range of contacts	12-250 V AC/DC
Uimp	Uimp=4 kV
Short-circuit protection	6 A gG per root (1DOC, 2DOC)
Lowest switched power for correct signals	1 W or 1 VA

# Universal Motor Controller

## UMC100-FBP

### Technical Description

<b>Relay Outputs</b>	
Switching of inductive power	Inductive loads need additional measures for spark suppression. Diodes for DC voltage and varistors / RC elements for AC voltage are suitable. Some DC coil contactors contain rectifiers which suppress sparks perfectly.
Switching capacity per relay contact acc. to EN 60947-5-1 (electromagnetic load)	AC-15 240 V AC: max. 1,5 A AC-15 120 V AC: max. 3 A DC-13 250 V DC max. 0.11 A DC-13 125 V DC max. 0.22 A DC-13 24 V DC max. 1 A
Relay contact service life	Mechanical 500 000 switching cycles  Electrical (250 V AC): 0.5 A: 100 000 cycles 1.5 A 50 000 switching
Internal clearance and creepage distances of relay contacts to 24 V circuits	> 5.5 mm (safety insulation up to 250 V AC) (EN 60947-1, Pollution degree 2) Pollution degree terminals: 3

<b>Digital Inputs DX111</b>	
Number of digital inputs	8 externally supplied, isolated inputs Type 1 accord. to EN 61131-1  1DI0 ... 1DI4 with common root 1DIZ 2DI5 ... 2DI7 with common root 2DIZ
Supply for digital inputs	24 V DC
Isolation	Yes
Input signal bounce suppression	Typ. 6 ms
Signal 0 range including ripple	-31.2 ... +5 V
Signal 1 range including ripple	+15 ... +31.2 V
Input current per channel (24 V DC)	Typ. 6.0 mA
Input resistor to 0 V	3.9 kΩ

# Universal Motor Controller

## UMC100-FBP

### Technical Description

<b>Digital Inputs DX111</b>	
Cable length	unshielded max. 600 m shielded max. 1000 m

<b>Digital Inputs DX122</b>	
Number of digital inputs	8 externally supplied, isolated inputs Type 2 accord. to EN 61131-1  1DI0 ... 1DI4 with common root 1DIZ 2DI5 ... 2DI7 with common root 2DIZ
Supply for digital inputs	110 V AC - 240 V AC
Isolation	Yes
Input signal bounce suppression	Typ. 20 ms
Signal 0 range including ripple	0 ... 40 V AC
Signal 1 range including ripple	74 ... 265 V AC
Frequency range	45 ... 65 Hz
Input current per channel (230V AC)	Typ. 10 mA

<b>Analogue Output</b>	
Type of connection	2-wire connection to display e.g. the motor current on an analogue meter.
Configurable output range	0-10 mA, 0/4 mA - 20 mA, 0-10 V
Cable shielding	Recommended for up to 30 m and outside the switchgear cabinet; shielding mandatory for cables over 30 m
Max. output voltage	10 V
Accuracy	< 5%
Max. output load	500 $\Omega$ (if configured as current output)
Min. output load	1 k $\Omega$ (if configured as voltage output)
Resolution	8 bit
Short-circuit-proof	Yes
Open-wire detection Short-circuit detection	Yes, if configured as 0/4-20 mA output Yes, if configured as 0-10V output
Isolation	No

# Universal Motor Controller

## UMC100-FBP

### Technical Description

#### VI150 and VI155

<b>General</b>	
Mounting	Snap-on mounting onto 35 mm standard mounting rails
Mounting position	Any.  A distance of 10 mm left and right to the L1 and L3 terminals might be necessary depending on the other devices mounted beside for voltages > 230 V / 400 V respectively.
Dimensions (W x H x D)	22.5 x 77 x 100 mm (excluding communication connector)
LEDs: Red/yellow/green	Red: Error of module Yellow: Diagnosis available Green: Ready for operation
Supply voltage	24 V DC (+30 % ... -20 %) (19.2 ... 31.2 V DC) including ripple
Supply current (relay activated)	VI150: Max. 40 mA (at 19.2 ... 31.2 V DC) VI155: Max. 55 mA (at 19.2 ... 31.2 V DC)
Tightening torque for the input, output and supply terminals	See DX1xx module
Tightening torque for the communication terminals	See DX1xx module
Net weight	0.11 kg
Degree of protection	IP20
Temperature range	storage -25 ... +70 °C operation 0 ... +60 °C
Marks, Approvals	CE, cUL Further in preparation. Ask your local sales representative for other marks/approvals.
Operation altitude above sea level	VI150: max. 2000 m VI155: max. 4000 m at 60 °C For higher altitudes please contact your sales unit.

<b>Relay Outputs</b>	
Number of relay outputs	1 DO0 with root DOC
Voltage range of contacts	12-250 V AC/DC
$U_{imp}$	$U_{imp}=4$ kV
Other technical data for the relay outputs see the DX1xx module	

# Universal Motor Controller

## UMC100-FBP

### Technical Description

#### Voltage Inputs L1, L2, L3

Overvoltage category	III in grounded networks II in ungrounded networks
Nominal input range (line to line voltage)	150 - 690 V AC
U <sub>imp</sub>	U <sub>imp</sub> = 8 kV
Voltage measuring in the nominal input range	+/- 2 %
Power factor: 0.4 ... 0.95	+/- 3.5 % for I > 0.75A
Real power kW	+/- 5 % typ.
Energy kWh	+/- 5 % typ.
THD	%
Rated Operational Voltage U <sub>e</sub>	690 V AC line to line
Usage in grounded/ungrounded networks	VI155 can be used in grounded and ungrounded networks VI150 can only be used in grounded networks. See installation instructions in section 2.
Voltage supply cables	 Note that the connection cables for voltage measurement may require additional cable protection

#### EMC UMC100 and DX1xx / VI15x Modules

Measurement of radiated and conducted interference according to EN61131-2 CISPR16-2-3	Class A
Electrostatic discharge according to IEC 61000-6-2	8 kV air discharge 6 kV contact discharge
Radiofrequency electromagnetic field according to IEC 61000-4-3	10 V/m
Fast transient bursts according to EN61000-4-4	2 kV power supply
High energy surges according to EN61000-4-5	1/0,5 kV CM/DM
Conducted radio frequency interference according to EN61000-4-6	10 V

#### VI15x

Measurement of radiated and conducted interference according to EN61131-2 CISPR16-2-3	Class A
Electrostatic discharge according to IEC 61000-6-2	8 kV air discharge 6 kV contact discharge
Radiofrequency electromagnetic field according to IEC 61000-4-3	10 V/m
Fast transient bursts according to EN61000-4-4	2 kV power supply
High energy surges according to EN61000-4-5	1/0,5 kV CM/DM power supply 2/1 kV CM/DM L1/L2/L3 voltage inputs
Conducted radio frequency interference according to EN61000-4-6	10 V
Damped oscillatory wave acc. to EN61000-4-18	Only voltage inputs L1/L2/L3: 2.5 kV / 1 kV CM / DM
Immunity low frequency harmonics acc. to EN61000-4-11	Power supply: 50 ... 12 kHz, 3V

# Universal Motor Controller UMC100-FBP Technical Description

## Dimensions UMC100

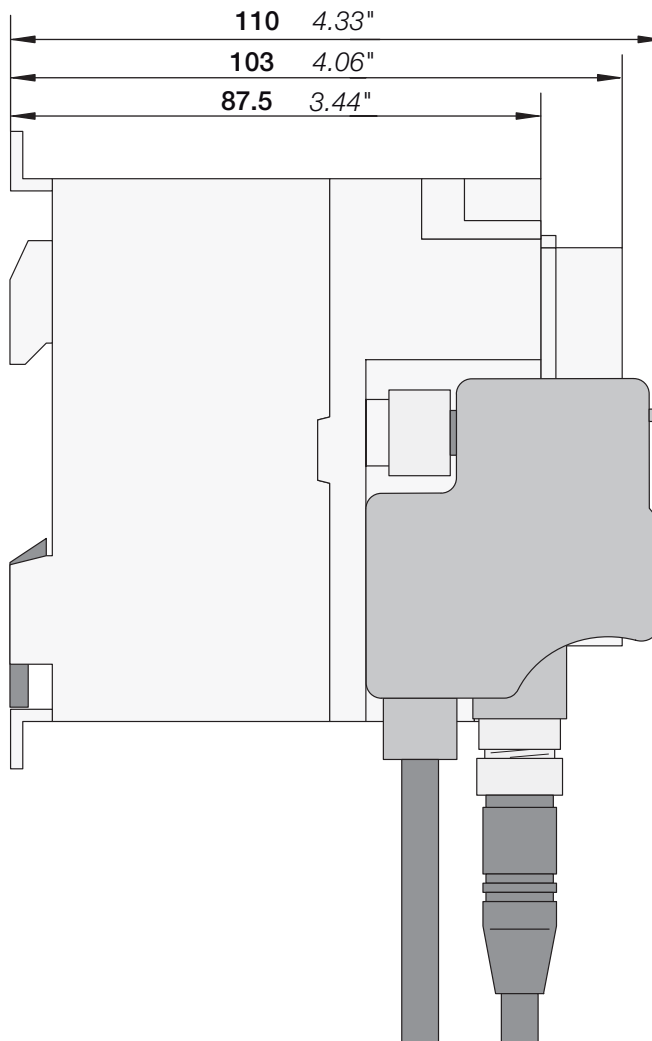
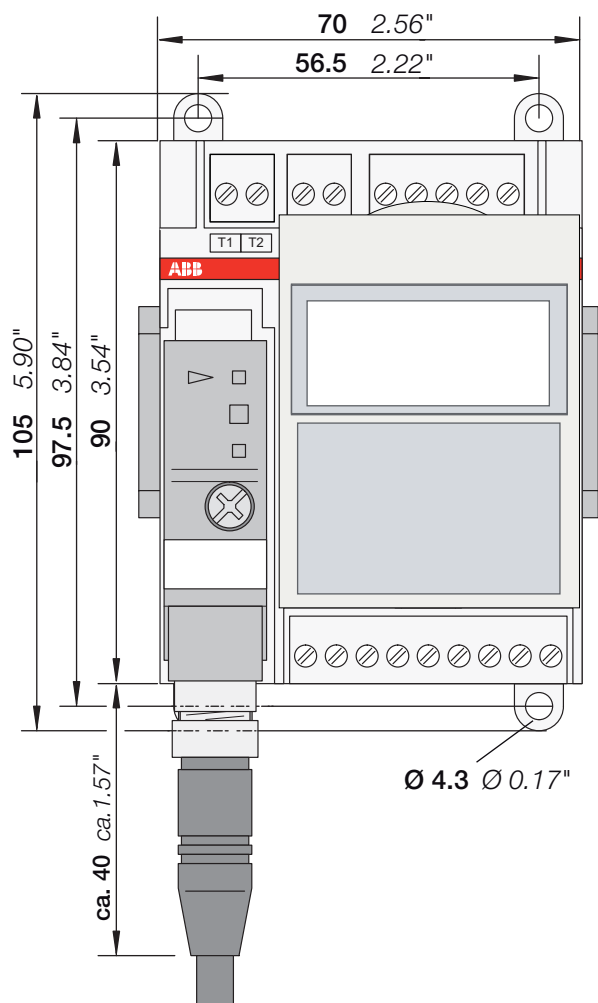
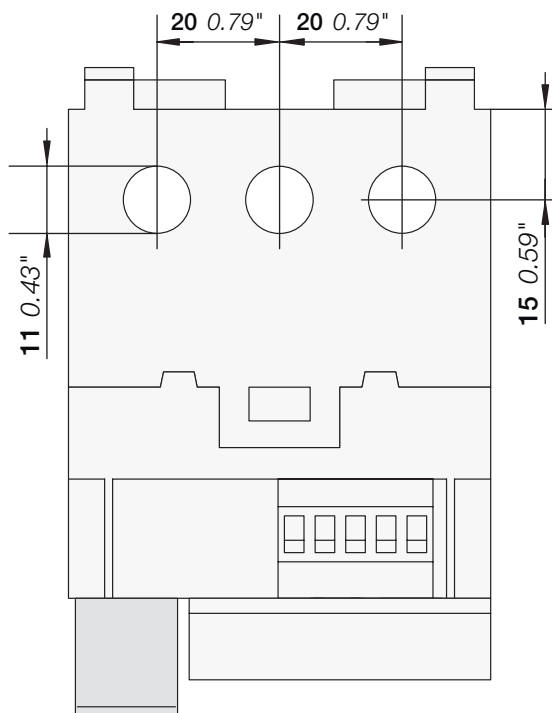

# Universal Motor Controller UMC100-FBP Technical Description

## Dimensions Expansion Modules

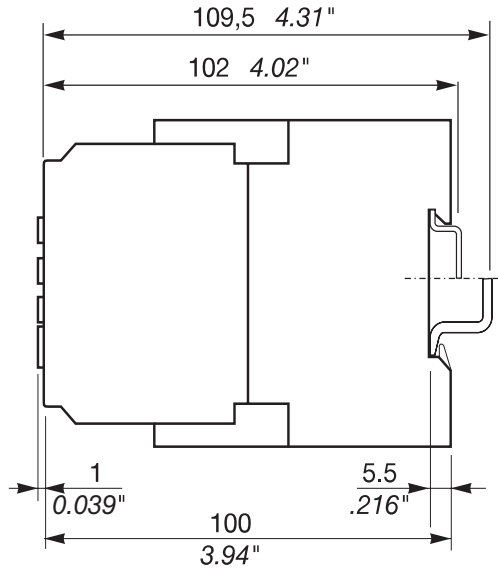

DX111, DX122, VI150, VI155

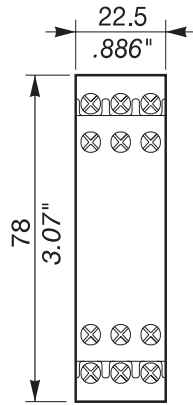

VI150, VI155

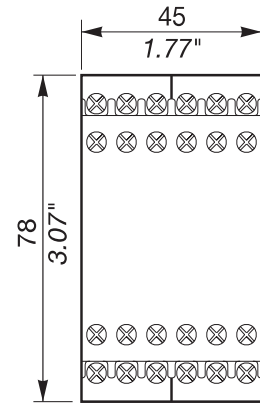

DX111, DX122

1SVC110000F0177.eps

## Dimensions LCD Panel

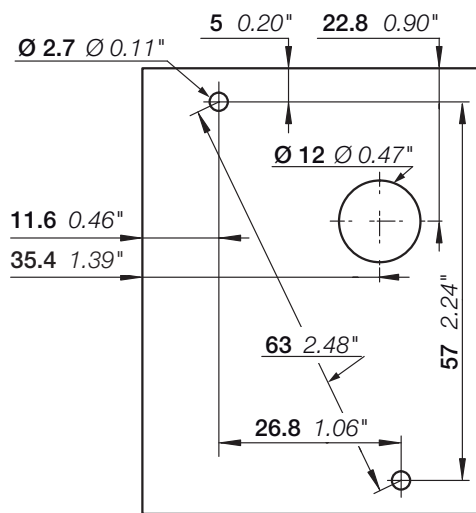

Drilling plan for door mounting

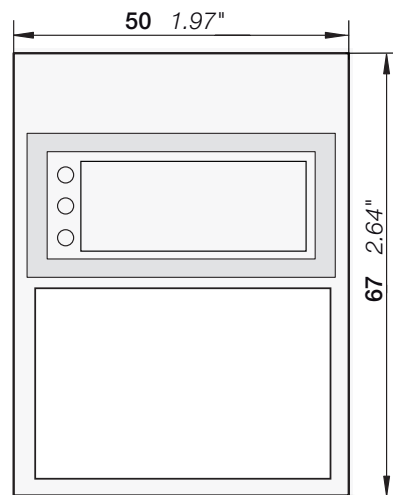

Frontal view LCD panel

2CDC342002F0011.eps

---

**Universal Motor Controller  
UMC100-FBP  
Technical Description**

---

**FAX No.: +49 (0) 6221-701-1382**

## Detected an Error?

Your feedback helps us to constantly improve our products. We are grateful for your comments and suggestions. Please provide us with the following information if you have noticed an issue:

Name

---

Company / Department

---

Telephone / Email

---

Problem Description

- Steps to reproduce the problem
- Version of UMC (Ident number on nameplate and firmware version which is displayed on the UMC100-PAN)
- Version of PBDTM (ControlPanel->Software) / AssetVisionBasic (Help->About) / Windows (Control->System)

---

---

---

---

---

---

---

---

---

---

---

---

---

---

---



---

**Universal Motor Controller  
UMC100-FBP  
Technical Description**

---



# Contact

## **ABB STOTZ-KONTAKT GmbH**

P. O. Box 10 16 80  
69006 Heidelberg, Germany

Phone: +49 (0) 6221 7 01-0  
Fax: +49 (0) 6221 7 01-240  
E-Mail: [plc.support@de.abb.com](mailto:plc.support@de.abb.com)  
Internet: <http://www.abb.de/stotzkontakt>

### **Note:**

We reserve the right to make technical changes or modify the contents of this document without prior notice. With regard to purchase orders, the agreed particulars shall prevail. ABB AG does not accept any responsibility whatsoever for potential errors or possible lack of information in this document.

We reserve all rights in this document and in the subject matter and illustrations contained therein. Any reproduction, disclosure to third parties or utilization of its contents – in whole or in parts – is forbidden without prior written consent of ABB AG.

Copyright© ABB  
All rights reserved

2CDC 135 013 D0203 06.2013