



THIS DRAWING IS SUPPLIED FOR INFORMATION ONLY. DESIGN FEATURES, SPECIFICATIONS AND PERFORMANCE DATA SHOWN HEREON ARE THE PROPERTY OF THE AMPHENOL CORPORATION. NO RIGHTS OF REPRODUCTION ARE IMPLIED. ALL DIMENSIONS ARE SUBJECT TO NORMAL MANUFACTURING VARIATIONS.

**Customer Drawing**

Standard Part List (Without HVIL)

P/N	Model NO.	Polarization
AC-HA001808	PL00X-300-10H10	X
AC-HA001809	PL00Y-300-10H10	Y
AC-HA001810	PL00U-300-10H10	U
AC-HA001811	PL00V-300-10H10	V
AC-HA001812	PL00W-300-10H10	W

- Notices:
- All non-dimensioned surfaces according to 3D-model &  $\nabla 3$
  - Planeness of panel surface should less than or equal to 0.1mm
  - Roughness of panel surface should be  $\sqrt{0.63}$  or better.
  - Thickness of panel should not exceed 12mm.

- 规格参数 (Spec.):
- 工作温度 Operating temperature:  $-40^{\circ}\text{C} \sim +125^{\circ}\text{C}$ .
  - 带高压互锁 Electrical interlock (HVIL).
  - 额定电流 Current rating:  
Power: 300A; HVIL: 5A.
  - 额定电压 Operating voltage:  
Power: 1000 VDC; Signal: 60 VDC.
  - 耐电压 Dielectric withstanding voltage:

- 与插头对插后, Pin与铁壳之间  
After mating, between pin and metal shell :5000 VDC.
  - 与插头对插后, Pin与HVIL之间  
After mating, between pin and HVIL :5000 VDC.
  - 与插头对插后, HVIL与铁壳之间  
After mating, between HVIL and metal shell :500 VDC.
  - 与插头对插前, 两个HVIL端子之间耐压  
Before mating, between two HVIL terminals :500 VDC.
- 防护等级 Protection class: IP67 & IP2X.
  - 电磁屏蔽 Shielding.
  - 机械寿命 Mating cycle: 100 Min.
  - 带自动二次锁扣 Automatic secondary lock.
  - 铜排推荐安装扭矩 Recommended Fasten Torque on Lug:  
M6 :  $3.6 \sim 4.4 \text{ Nm}$   
M8 :  $7.2 \sim 8.8 \text{ Nm}$   
M10:  $17.1 \sim 20.9 \text{ Nm}$
  - 推荐法兰盘螺丝安装扭矩 Recommended Screw Assembly Torque on Flange :  $1.6 \sim 2.4 \text{ Nm}$

Standard Part List (With HVIL)

P/N	Model NO.	Polarization
AC-HA000300	PL00X-301-10M10	X
AC-HA000301	PL00Y-301-10M10	Y
AC-HA000302	PL00U-301-10M10	U
AC-HA000303	PL00V-301-10M10	V
AC-HA000304	PL00W-301-10M10	W
AC-HA001383	PL00T-301-10M10	T
AC-HA000454	PL00X-301-10D10	X
AC-HA000455	PL00Y-301-10D10	Y
AC-HA000456	PL00U-301-10D10	U
AC-HA000457	PL00V-301-10D10	V
AC-HA000458	PL00W-301-10D10	W
AC-HA001382	PL00T-301-10D10	T
AC-HA001088	PL00X-301-10D8	X
AC-HA001089	PL00Y-301-10D8	Y
AC-HA001090	PL00U-301-10D8	U
AC-HA001091	PL00V-301-10D8	V
AC-HA001092	PL00W-301-10D8	W
AC-HA001388	PL00T-301-10D8	T
AC-HA001976	PL00X-301-10M8	X
AC-HA001977	PL00Y-301-10M8	Y
AC-HA001978	PL00U-301-10M8	U
AC-HA001979	PL00V-301-10M8	V
AC-HA001980	PL00W-301-10M8	W
AC-HA001981	PL00T-301-10M8	T
AC-HA003940	PL00X-301-10D6	X
AC-HA003941	PL00Y-301-10D6	Y
AC-HA003942	PL00U-301-10D6	U
AC-HA003943	PL00V-301-10D6	V
AC-HA003944	PL00W-301-10D6	W
AC-HA003945	PL00T-301-10D6	T
AC-HA003934	PL00X-301-10M6	X
AC-HA003935	PL00Y-301-10M6	Y
AC-HA003936	PL00U-301-10M6	U
AC-HA003937	PL00V-301-10M6	V
AC-HA003938	PL00W-301-10M6	W
AC-HA003939	PL00T-301-10M6	T

Standard Part List (Without HVIL)

P/N	Model NO.	Polarization
AC-HA000407	PL00X-300-10M8	X
AC-HA000408	PL00Y-300-10M8	Y
AC-HA000976	PL00U-300-10M8	U
AC-HA000410	PL00V-300-10M8	V
AC-HA000409	PL00W-300-10M8	W
AC-HA001398	PL00T-300-10M8	T
AC-HA000464	PL00X-300-10D10	X
AC-HA000465	PL00Y-300-10D10	Y
AC-HA000466	PL00U-300-10D10	U
AC-HA000467	PL00V-300-10D10	V
AC-HA000468	PL00W-300-10D10	W
AC-HA001385	PL00T-300-10D10	T
AC-HA000474	PL00X-300-10M10	X
AC-HA000475	PL00Y-300-10M10	Y
AC-HA000476	PL00U-300-10M10	U
AC-HA000477	PL00V-300-10M10	V
AC-HA000478	PL00W-300-10M10	W
AC-HA001386	PL00T-300-10M10	T
AC-HA002139	PL00X-300-10D8	X
AC-HA002140	PL00Y-300-10D8	Y
AC-HA002141	PL00U-300-10D8	U
AC-HA002142	PL00V-300-10D8	V
AC-HA002143	PL00W-300-10D8	W
AC-HA002144	PL00T-300-10D8	T
AC-HA003928	PL00X-300-10D6	X
AC-HA003929	PL00Y-300-10D6	Y
AC-HA003930	PL00U-300-10D6	U
AC-HA003931	PL00V-300-10D6	V
AC-HA003932	PL00W-300-10D6	W
AC-HA003933	PL00T-300-10D6	T
AC-HA003922	PL00X-300-10M6	X
AC-HA003923	PL00Y-300-10M6	Y
AC-HA003924	PL00U-300-10M6	U
AC-HA003925	PL00V-300-10M6	V
AC-HA003926	PL00W-300-10M6	W
AC-HA003927	PL00T-300-10M6	T

订购信息 Ordering Information

PL00 X - 30 0 - 10 D 10

键位及颜色 Key & Color	高压互锁 HVIL	孔种类 Hole Type	联接螺栓 Bolt Size
"X", 橙色 Orange "Y", 黑色 Black "U", 黄色 Yellow "V", 绿色 Green "W", 红色 Red "T", 蓝色 Blue	0, 不带互锁 No HVIL 1, 带互锁 With HVIL	D, 通孔 Through Hole M, 螺纹孔 Screw Hole	Customer Define

REVISIONS						
REV	ZONE	ECO	DESCRIPTION	DATE	BY	APPR
A	--	--	Add dimentions	01/09/15	RW	EC
F	--	--	Change HVIL Wire & Dust Cap, Update Spec.	03/30/16	RW	GX
G	--	--	Add Geometric Tolerance of Flange & Panel 增加倒角标注	10/21/16	RW	PL
H	--	--	修改倒角错误	01/16/17	SW	TS
I	--	--	修改图面错误	12/11/19	Steven	JL

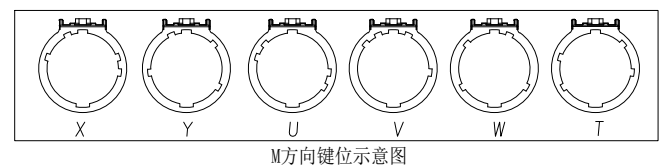
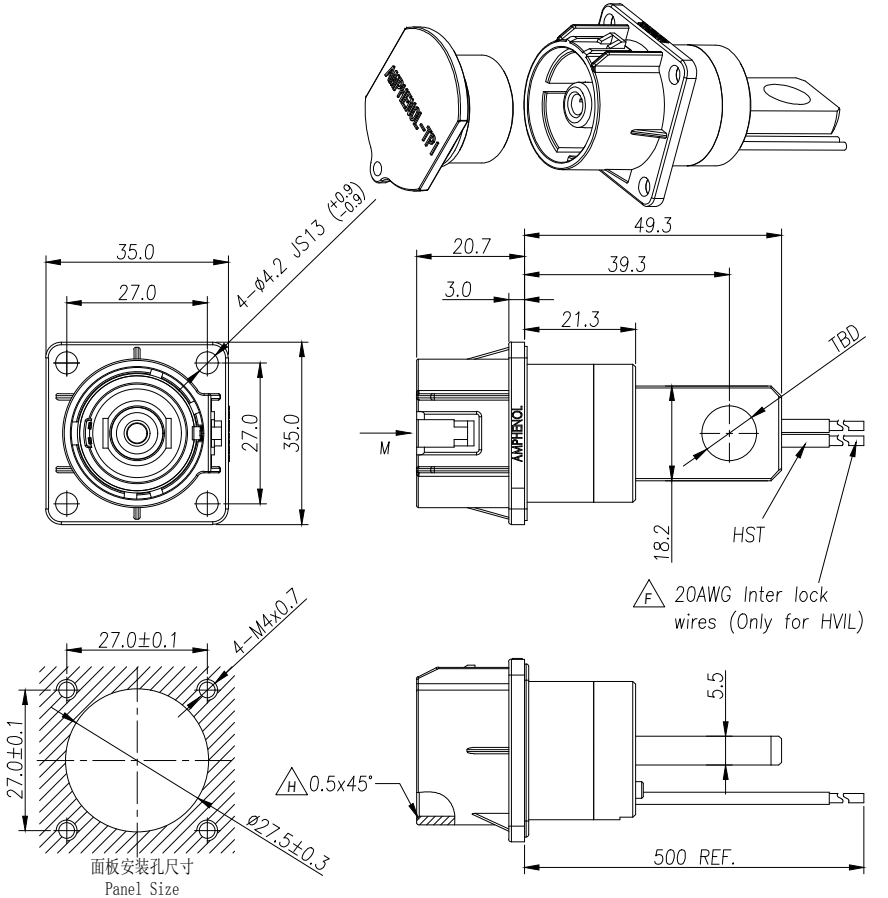

	Amphenol Technical Products International GZ				PART NAME: PwrLok 10mm IPOS Rcpt Lug	
	第三角投影 THIRD ANGLE PROJECTION	页面 SHEET	幅面 SIZE	版次 REV.	比例 SCALE	DWG NO: PL00-300-10
签名 SIGNATURE	日期 DATE	UNLESS OTHERWISE SPECIFIED			CUST REV.:	
制图 DRAWN	Steven	1) All dimensions are in metric(mm).	1 PL DEC $\pm 1.00$			-
审核 CHECKED	YM	2) Tolerances are as follows:	1 PL DEC $\pm 0.50$			
批准 APPROVAL	JL		2 PL DEC $\pm 0.20$			
		Angles $\pm 1^{\circ}$				